



# DL205 Analog I/O Modules

Manual Number D2-ANLG-M

---



# WARNING

Thank you for purchasing automation equipment from **Automationdirect.com**<sup>™</sup>. We want your new **DirectLOGIC**<sup>™</sup> automation equipment to operate safely. Anyone who installs or uses this equipment should read this publication (and any other relevant publications) before installing or operating the equipment.

To minimize the risk of potential safety problems, you should follow all applicable local and national codes that regulate the installation and operation of your equipment. These codes vary from area to area and usually change with time. It is your responsibility to determine which codes should be followed, and to verify that the equipment, installation, and operation are in compliance with the latest revision of these codes.

At a minimum, you should follow all applicable sections of the National Fire Code, National Electrical Code, and the codes of the National Electrical Manufacturer's Association (NEMA). There may be local regulatory or government offices that can also help determine which codes and standards are necessary for safe installation and operation.

*Equipment damage or serious injury to personnel can result from the failure to follow all applicable codes and standards. We do not guarantee the products described in this publication are suitable for your particular application, nor do we assume any responsibility for your product design, installation, or operation.*

*Our products are not fault-tolerant and are not designed, manufactured or intended for use or resale as on-line control equipment in hazardous environments requiring fail-safe performance, such as in the operation of nuclear facilities, aircraft navigation or communication systems, air traffic control, direct life support machines, or weapons systems, in which the failure of the product could lead directly to death, personal injury, or severe physical or environmental damage ("High Risk Activities"). **Automationdirect.com**<sup>™</sup> specifically disclaims any expressed or implied warranty of fitness for High Risk Activities.*

For additional warranty and safety information, see the Terms and Conditions section of our Desk Reference. If you have any questions concerning the installation or operation of this equipment, or if you need additional information, please call us at 770-844-4200.

This publication is based on information that was available at the time it was printed. At **Automationdirect.com**<sup>™</sup> we constantly strive to improve our products and services, so we reserve the right to make changes to the products and/or publications at any time without notice and without any obligation. This publication may also discuss features that may not be available in certain revisions of the product.



## Trademarks

This publication may contain references to products produced and/or offered by other companies. The product and company names may be trademarked and are the sole property of their respective owners. **Automationdirect.com**<sup>™</sup> disclaims any proprietary interest in the marks and names of others.

**Copyright 2002, Automationdirect.com**<sup>™</sup> Incorporated  
All Rights Reserved

No part of this manual shall be copied, reproduced, or transmitted in any way without the prior, written consent of **Automationdirect.com**<sup>™</sup> Incorporated. **Automationdirect.com**<sup>™</sup> retains the exclusive rights to all information included in this document.



# AVERTISSEMENT



Nous vous remercions d'avoir acheté l'équipement d'automatisation de **Automationdirect.com**™. Nous tenons à ce que votre nouvel équipement d'automatisation **DirectLOGIC**™ fonctionne en toute sécurité. Toute personne qui installe ou utilise cet équipement doit lire la présente publication (et toutes les autres publications pertinentes) avant de l'installer ou de l'utiliser.

Afin de réduire au minimum le risque d'éventuels problèmes de sécurité, vous devez respecter tous les codes locaux et nationaux applicables régissant l'installation et le fonctionnement de votre équipement. Ces codes diffèrent d'une région à l'autre et, habituellement, évoluent au fil du temps. Il vous incombe de déterminer les codes à respecter et de vous assurer que l'équipement, l'installation et le fonctionnement sont conformes aux exigences de la version la plus récente de ces codes.

Vous devez, à tout le moins, respecter toutes les sections applicables du Code national de prévention des incendies, du Code national de l'électricité et des codes de la National Electrical Manufacturer's Association (NEMA). Des organismes de réglementation ou des services gouvernementaux locaux peuvent également vous aider à déterminer les codes ainsi que les normes à respecter pour assurer une installation et un fonctionnement sûrs.

L'omission de respecter la totalité des codes et des normes applicables peut entraîner des dommages à l'équipement ou causer de graves blessures au personnel. Nous ne garantissons pas que les produits décrits dans cette publication conviennent à votre application particulière et nous n'assumons aucune responsabilité à l'égard de la conception, de l'installation ou du fonctionnement de votre produit.

Nos produits ne sont pas insensibles aux défaillances et ne sont ni conçus ni fabriqués pour l'utilisation ou la revente en tant qu'équipement de commande en ligne dans des environnements dangereux nécessitant une sécurité absolue, par exemple, l'exploitation d'installations nucléaires, les systèmes de navigation aérienne ou de communication, le contrôle de la circulation aérienne, les équipements de survie ou les systèmes d'armes, pour lesquels la défaillance du produit peut provoquer la mort, des blessures corporelles ou de graves dommages matériels ou environnementaux ("activités à risque élevé"). La société **Automationdirect.com**™ nie toute garantie expresse ou implicite d'aptitude à l'emploi en ce qui a trait aux activités à risque élevé.

Pour des renseignements additionnels touchant la garantie et la sécurité, veuillez consulter la section Modalités et conditions de notre documentation. Si vous avez des questions au sujet de l'installation ou du fonctionnement de cet équipement, ou encore si vous avez besoin de renseignements supplémentaires, n'hésitez pas à nous téléphoner au 770-844-4200.

Cette publication s'appuie sur l'information qui était disponible au moment de l'impression. À la société **Automationdirect.com**™, nous nous efforçons constamment d'améliorer nos produits et services. C'est pourquoi nous nous réservons le droit d'apporter des modifications aux produits ou aux publications en tout temps, sans préavis ni quelque obligation que ce soit. La présente publication peut aussi porter sur des caractéristiques susceptibles de ne pas être offertes dans certaines versions révisées du produit.

## Marques de commerce

La présente publication peut contenir des références à des produits fabriqués ou offerts par d'autres entreprises. Les désignations des produits et des entreprises peuvent être des marques de commerce et appartiennent exclusivement à leurs propriétaires respectifs. **Automationdirect.com**™ nie tout intérêt dans les autres marques et désignations.

Copyright 2002, **Automationdirect.com**™ Incorporated

Tous droits réservés

Nulle partie de ce manuel ne doit être copiée, reproduite ou transmise de quelque façon que ce soit sans le consentement préalable écrit de la société **Automationdirect.com**™ Incorporated. **Automationdirect.com**™ conserve les droits exclusifs à l'égard de tous les renseignements contenus dans le présent document.

# Manual Revisions

---

*If you contact us in reference to this manual, be sure to include the edition or revision number.*

**Title:** DL205 Analog I/O Manual

**Manual Number:** D2-ANLG-M

Edition/Rev	Date	Description of Changes
Original	1/94	original issue
2nd Edition	4/95	New Edition
3rd Edition	9/97	Added new modules
4th Edition	4/99	Added new modules
5th Edition	5/00	Added new modules
6th Edition	4/02	Added new modules
6th Edition Rev A	6/02	Added DL250-1 and DL260 CPUs and removed references to DL250 CPU (Note: DL250 has same functionality as DL250-1 except for local expansion I/O capability.)
6th Edition Rev B	8/02	Minor corrections

# Table of Contents

---

## Chapter 1: Getting Started

<b>Introduction</b> .....	<b>1-2</b>
The Purpose of this Manual .....	1-2
Supplemental Manuals .....	1-2
Technical Support .....	1-2
Chapters .....	1-3
<b>Conventions Used</b> .....	<b>1-4</b>
Key Topics for Each Chapter .....	1-4
<b>Physical Characteristics</b> .....	<b>1-4</b>
<b>Analog Input Module Terminology</b> .....	<b>1-5</b>
Channels per Module .....	1-5
Input Ranges .....	1-5
Resolution .....	1-5
Input Type .....	1-5
Input Impedance .....	1-5
Conversion Method .....	1-5
PLC Update Rate .....	1-5
Linearity Error .....	1-5
Maximum Inaccuracy .....	1-5
Accuracy vs. Temperature .....	1-5
I/O Points Required .....	1-5
External Power Source .....	1-5
Base Power Required .....	1-5
Operating Temperature .....	1-5
Relative Humidity .....	1-5
Step Response .....	1-5
<b>Analog Output Module Terminology</b> .....	<b>1-6</b>
Channels per Module .....	1-6
Output Ranges .....	1-6
Resolution .....	1-6
Output Current .....	1-6
Output Impedance .....	1-6
Load Impedance .....	1-6
PLC Update Rate .....	1-6
Linearity Error .....	1-6
Maximum Inaccuracy .....	1-6
Accuracy vs. Temperature .....	1-6
External Power Source .....	1-6
Base Power Required .....	1-6
Operating Temperature .....	1-6
Relative Humidity .....	1-6
I/O Points Required .....	1-6
<b>Selecting the Appropriate Module</b> .....	<b>1-7</b>
Wide Variety of Modules .....	1-7
Diagnostic Features .....	1-7

---

Analog Input .....	1-8
Special Input .....	1-8
Analog Output .....	1-9
Combination Analog .....	1-9
<b>Analog Made Easy – Four Simple Steps .....</b>	<b>1-10</b>

## Chapter 2: F2-04AD-1, F2-04AD-1L 4-Channel Analog Current Input

<b>Module Specifications .....</b>	<b>2-2</b>
Input Specifications .....	2-3
General Specifications .....	2-3
Analog Input Configuration Requirements .....	2-3
Special Placement Requirements (DL230 Only and Remote I/O Bases) .....	2-4
<b>Setting the Module Jumpers .....</b>	<b>2-5</b>
Selecting the Number of Channels .....	2-5
<b>Connecting the Field Wiring .....</b>	<b>2-5</b>
Wiring Guidelines .....	2-5
User Power Supply Requirements .....	2-5
Current Loop Transmitter Impedance .....	2-6
Wiring Diagram .....	2-7
<b>Module Operation .....</b>	<b>2-8</b>
Channel Scanning Sequence with a DL230 CPU .....	2-8
Channel Scanning Sequence with a DL240/250-1/260 CPU .....	2-9
Analog Module Updates .....	2-9
Understanding the Input Assignments .....	2-10
Analog Data Bits .....	2-10
Active Channel Indicator Inputs .....	2-11
Module Diagnostic Inputs .....	2-11
Module Resolution .....	2-11
<b>Writing the Control Program .....</b>	<b>2-12</b>
Reading Values: Pointer Method and Multiplexing .....	2-12
Pointer Method .....	2-12
Reading Values (Multiplexing) .....	2-14
Single Channel Selected .....	2-15
Analog Power Failure Detection .....	2-15
Scaling the Input Data .....	2-15
Analog and Digital Value Conversions .....	2-16
Filtering Input Noise (DL250-1/260 CPU Only) .....	2-17

## Chapter 3: F2-04AD-2, F2-04AD-2L 4-Channel Analog Voltage Input

<b>Module Specifications</b> .....	<b>3-2</b>
Input Specifications .....	3-3
General Specifications .....	3-3
Analog Input Configuration Requirements .....	3-3
Special Placement Requirements (DL230 Only and Remote I/O Bases) .....	3-4
<b>Setting the Module Jumpers</b> .....	<b>3-5</b>
Selecting the Number of Channels .....	3-5
Selecting the Input Signal Range .....	3-5
<b>Connecting the Field Wiring</b> .....	<b>3-6</b>
Wiring .....	3-6
Guidelines .....	3-6
User Power Supply Requirements .....	3-6
Custom Input Ranges .....	3-7
Wiring Diagram .....	3-8
<b>Module Operation</b> .....	<b>3-9</b>
Channel Scanning Sequence with a DL230 CPU .....	3-9
Channel Scanning Sequence with a DL240/250-1/260 CPU .....	3-10
Analog Module Updates .....	3-10
Understanding the Input Assignments .....	3-11
Analog Data Bits .....	3-11
Active Channel Indicator Inputs .....	3-11
Module Diagnostic and Sign Inputs .....	3-12
Module Resolution .....	3-12
<b>Writing the Control Program</b> .....	<b>3-13</b>
Reading Values: Pointer Method and Multiplexing .....	3-13
Pointer Method .....	3-13
Using Bipolar Ranges (Pointer Method) .....	3-14
Reading Values (Multiplexing) .....	3-16
Single Channel Selected .....	3-17
Using Bipolar Ranges (Multiplexing) .....	3-17
Using 2's Complement (Multiplexing) .....	3-18
Analog Power Failure Detection .....	3-19
Scaling the Input Data .....	3-19
Analog and Digital Value Conversions .....	3-20
Filtering Input Noise (DL250-1/260 CPU Only) .....	3-21

## Chapter 4: F2-08AD-1 8-Channel Analog Current Input

<b>Module Specifications</b> .....	<b>4-2</b>
Input Specifications .....	4-3
General Specifications .....	4-3
Analog Input Configuration Requirements .....	4-3
Special Placement Requirements (DL230 Only and Remote I/O Bases) .....	4-4
<b>Setting the Module Jumpers</b> .....	<b>4-5</b>
Selecting the Number of Channels .....	4-5
<b>Connecting the Field Wiring</b> .....	<b>4-6</b>
Wiring Guidelines .....	4-6

User Power Supply Requirements .....	4-6
Current Loop Transmitter Impedance .....	4-6
Wiring Diagram .....	4-7
<b>Module Operation .....</b>	<b>4-8</b>
Channel Scanning Sequence with a DL230 CPU .....	4-8
Channel Scanning Sequence with a DL240/250-1/260 CPU .....	4-9
Analog Module Updates .....	4-9
Understanding the Input Assignments .....	4-10
Analog Data Bits .....	4-10
Active Channel Indicator Inputs .....	4-11
Module Diagnostic Inputs .....	4-11
Module Resolution .....	4-11
<b>Writing the Control Program .....</b>	<b>4-12</b>
Reading Values: Pointer Method and Multiplexing .....	4-12
Pointer Method .....	4-12
Multiplexing .....	4-14
Single Channel Selected .....	4-15
Analog Power Failure Detection .....	4-15
Scaling the Input Data .....	4-15
Analog and Digital Value Conversions .....	4-16
Filtering Input Noise (DL250-1/260 CPU Only) .....	4-17

## Chapter 5: F2-08AD-2 8-Channel Analog Voltage Input

<b>Module Specifications .....</b>	<b>5-2</b>
Input Specifications .....	5-3
General Specifications .....	5-3
Analog Input Configuration Requirements .....	5-3
Special Placement Requirements (DL230 and Remote I/O Bases) .....	5-4
<b>Setting the Module Jumpers .....</b>	<b>5-5</b>
Selecting the Number of Channels .....	5-5
Selecting Input Voltage Range .....	5-5
<b>Connecting the Field Wiring .....</b>	<b>5-6</b>
Wiring Guidelines .....	5-6
User Power Supply Requirements .....	5-6
Wiring Diagram .....	5-7
<b>Module Operation .....</b>	<b>5-8</b>
Channel Scanning Sequence with a DL230 CPU .....	5-8
Channel Scanning Sequence with a DL240/250-1/260 CPU .....	5-8
Analog Module Updates .....	5-9
Understanding the Input Assignments .....	5-9
Analog Data Bits .....	5-9
Active Channel Indicator Inputs .....	5-10
Module Diagnostic and Sign .....	5-10
Module Resolution .....	5-10
<b>Writing the Control Program .....</b>	<b>5-11</b>
Reading Values: Pointer Method and Multiplexing .....	5-11
Pointer Method .....	5-11
Using Bipolar Ranges (Pointer Method) .....	5-12
Reading Values (Multiplexing) .....	5-14

Single Channel Selected .....	5-14
Using Bipolar Ranges (Multiplexing) .....	5-15
Using 2's Complement (Multiplexing) .....	5-16
Analog Power Failure Detection .....	5-17
Scaling the Input Data .....	5-17
Analog and Digital Value Conversions .....	5-18
Filtering Input Noise (DL250-1/260 CPU Only) .....	5-19

## Chapter 6: F2-04RTD 4-Channel RTD Input

<b>Module Specifications</b> .....	<b>6-2</b>
Module Calibration .....	6-2
RTD Input Configuration Requirements .....	6-2
Input Specifications .....	6-3
Special Placement Requirements (DL230 and Remote I/O Bases) .....	6-4
<b>Setting the Module Jumpers</b> .....	<b>6-5</b>
Jumper Locations .....	6-5
Selecting the Number of Channels .....	6-5
Setting Input Type .....	6-5
Selecting the Conversion Units .....	6-6
<b>Connecting the Field Wiring</b> .....	<b>6-7</b>
Wiring Guidelines .....	6-7
RTD – Resistance Temperature Detector .....	6-7
Ambient Variations in Temperature .....	6-7
Wiring Diagram .....	6-8
<b>Module Operation</b> .....	<b>6-9</b>
Channel Scanning Sequence (DL230) .....	6-9
Channel Scanning Sequence (DL240/250-1/260) .....	6-10
Analog Module Updates .....	6-10
<b>Writing the Control Program</b> .....	<b>6-11</b>
Reading Values: Pointer Method and Multiplexing .....	6-11
Pointer Method .....	6-11
Negative Temperature Readings with Magnitude Plus Sign (Pointer Method) .....	6-13
Negative Temperatures 2's Complement (Binary / Pointer Method) .....	6-15
Understanding the Input Assignments (Multiplexing Ladder Only) .....	6-15
Analog Data Bits .....	6-16
Active Channel Bits .....	6-16
Broken Transmitter Bits (Pointer and Multiplexing Ladder Methods) .....	6-16
Reading Magnitude Plus Sign Values (Multiplexing) .....	6-17
Reading 2's Complement Values (Multiplexing) .....	6-18
Scaling the Input Data .....	6-18
Filtering Input Noise (DL250-1/260 CPU Only) .....	6-19

## Chapter 7: F2-04THM 4-Channel Thermocouple Input

<b>Module Specifications</b> .....	<b>7-2</b>
General Specifications .....	7-2
Thermocouple Specifications .....	7-3
Voltage Specifications .....	7-3
Module Calibration .....	7-3
Thermocouple Input Configuration Requirements .....	7-3
Special Placement Requirements (DL230 and Remote I/O Bases) .....	7-4
<b>Setting the Module Jumpers</b> .....	<b>7-5</b>
Jumper Locations .....	7-5
Calibrate Enable .....	7-5
Selecting the Number of Channels .....	7-5
Setting Input Type .....	7-6
Selecting the Conversion Units .....	7-6
Thermocouple Conversion Units .....	7-6
Voltage Conversion Units .....	7-7
<b>Connecting the Field Wiring</b> .....	<b>7-8</b>
Wiring Guidelines .....	7-8
User Power Supply Requirements .....	7-8
Thermocouples .....	7-9
Ambient Variations in Temperature .....	7-9
Wiring Diagram .....	7-9
<b>Module Operation</b> .....	<b>7-11</b>
Channel Scanning Sequence with a DL230 CPU .....	7-11
Channel Scanning Sequence with a DL240/250-1/260 CPU .....	7-12
Analog Module Updates .....	7-12
<b>Writing the Control Program</b> .....	<b>7-13</b>
Reading Values: Pointer Method and Multiplexing .....	7-13
Pointer Method .....	7-13
Negative Temperature Readings with Magnitude Plus Sign (Pointer Method) .....	7-15
Negative Temperatures 2's Complement (Binary / Pointer Method) .....	7-17
Understanding the Input Assignments (Multiplexing Ladder Only) .....	7-17
Analog Data Bits .....	7-18
Active Channel Bits .....	7-18
Broken Transmitter Bits (Pointer and Multiplexing Ladder Methods) .....	7-18
Reading Magnitude Plus Sign Values (Multiplexing) .....	7-19
Reading 2's Complement Values (Multiplexing) .....	7-20
Scaling the Input Data .....	7-20
Module Resolution 16-Bit (Unipolar Voltage Input) .....	7-21
Module Resolution 15-Bit Plus Sign (Bipolar Voltage Input) .....	7-21
Analog and Digital Value Conversions .....	7-22
Filtering Input Noise (DL250-1/260 CPU Only) .....	7-23

## Chapter 8: F2-02DA-1, F2-02DA-1L 2-Channel Analog Current Output

<b>Module Specifications</b> .....	<b>8-2</b>
Output Specifications .....	8-3
General Specifications .....	8-3
Analog Output Configuration Requirements .....	8-3
Special Placement Requirements (DL230 and Remote I/O Bases) .....	8-4
<b>Connecting the Field Wiring</b> .....	<b>8-5</b>
Wiring Guidelines .....	8-5
User Power Supply Requirements .....	8-5
Wiring Diagram .....	8-6
Load Range .....	8-6
<b>Module Operation</b> .....	<b>8-7</b>
Channel Update Sequence with a DL230 CPU .....	8-7
Channel Scanning Sequence with a DL240/250-1/260 CPU .....	8-8
Understanding the Output Assignments .....	8-9
Channel Select .....	8-9
Outputs .....	8-9
Analog Data Bits .....	8-10
Module Resolution .....	8-10
<b>Writing the Control Program</b> .....	<b>8-11</b>
Reading Values: Pointer Method and Multiplexing .....	8-11
Pointer Method .....	8-11
Multiplexing .....	8-13
Sending Data to One Channel .....	8-14
Sending the Same Data to Both Channels .....	8-14
Calculating the Digital Value .....	8-15
Analog and Digital Value Conversions .....	8-15

## Chapter 9: F2-02DA-2, F2-02DA-2L 2-Channel Analog Voltage Output

<b>Module Specifications</b> .....	<b>9-2</b>
Output Specifications .....	9-3
General Specifications .....	9-3
Analog Output Configuration Requirements .....	9-3
Special Placement Requirements (DL230 and Remote I/O Bases) .....	9-4
<b>Setting the Module Jumpers</b> .....	<b>9-5</b>
Voltage Range and Output Combinations .....	9-6
<b>Connecting the Field Wiring</b> .....	<b>9-8</b>
Wiring Guidelines .....	9-8
User Power .....	9-8
Supply Requirements .....	9-8
Wiring Diagram .....	9-8
<b>Module Operation</b> .....	<b>9-9</b>
Channel Update Sequence with a DL230 CPU .....	9-9
Channel Scanning Sequence with a DL240/250-1/260 CPU .....	9-10
Understanding .....	9-11

the Output Assignments .....	9-11
Channel Select Outputs .....	9-11
Analog Data Bits .....	9-12
Signal Sign Output .....	9-12
Bipolar Output Data .....	9-12
Module Resolution .....	9-13
<b>Writing the Control Program .....</b>	<b>9-14</b>
Calculating the Digital Value .....	9-14
Negative Values with Bipolar Range .....	9-15
Writing Values: Pointer Method and Multiplexing .....	9-16
Writing Values (Pointer Method) .....	9-16
Writing Data (Multiplexing) .....	9-18
Sending Data to One Channel .....	9-20
Sending the Same Data to Both Channels .....	9-20
Analog and Digital Value Conversions .....	9-21

## Chapter 10: F2-08DA-1 8-Channel Analog Current Output

<b>Module Specifications .....</b>	<b>10-2</b>
Output Specifications .....	10-3
General Specifications .....	10-3
Analog Output Configuration Requirements .....	10-3
Special Placement Requirements (DL230 and Remote I/O Bases) .....	10-4
<b>Connecting the Field Wiring .....</b>	<b>10-5</b>
Wiring Guidelines .....	10-5
User Power .....	10-5
Supply Requirements .....	10-5
Wiring Diagram .....	10-6
Load Range .....	10-6
<b>Module Operation .....</b>	<b>10-7</b>
Channel Update Sequence (Multiplex Method) .....	10-7
Channel Update Sequence (Pointer Method) .....	10-8
Understanding the Output Assignments .....	10-8
Channel Select Outputs .....	10-9
Analog Data Bits .....	10-10
Output Enable .....	10-10
Module Resolution .....	10-10
<b>Writing the Control Program .....</b>	<b>10-11</b>
Calculating the Digital Value .....	10-11
Writing Values: Pointer Method and Multiplexing .....	10-12
Pointer Method Example .....	10-12
Multiplexing Example .....	10-13
Writing Data (Multiplexing Example) .....	10-14
Sending Data to One Channel .....	10-15
Analog and Digital Value Conversions .....	10-15

## Chapter 11: F2-08DA-2 8-Channel Analog Voltage Output

<b>Module Specifications</b> .....	<b>11-2</b>
Output Specifications .....	11-3
General Specifications .....	11-3
Analog Output Configuration Requirements .....	11-3
Special Placement Requirements (DL230 and Remote I/O Bases) .....	11-4
<b>Setting the Module Jumper</b> .....	<b>11-5</b>
Voltage Range and Output Combinations .....	11-5
<b>Connecting the Field Wiring</b> .....	<b>11-6</b>
Wiring Guidelines .....	11-6
User Power .....	11-6
Supply Requirements .....	11-6
Wiring Diagram .....	11-6
<b>Module Operation</b> .....	<b>11-7</b>
Channel Update Sequence (Multiplex Method) .....	11-7
Channel Update Sequence (Pointer Method) .....	11-8
Understanding the Output Assignments .....	11-9
Channel Select Outputs .....	11-9
Analog Data Bits .....	11-10
Output Enable .....	11-10
Module Resolution .....	11-10
<b>Writing the Control Program</b> .....	<b>11-11</b>
Calculating the Digital Value .....	11-11
Writing Values: Pointer Method and Multiplexing .....	11-12
Pointer Method Example .....	11-12
Multiplexing Example .....	11-14
Writing Data (Multiplexing Example) Continued .....	11-15
Sending Data to One Channel .....	11-16
Analog and Digital Value Conversions .....	11-16

## Chapter 12: F2-02DAS-1 4–20mA 2-Channel Analog Current Output

<b>Module Specifications</b> .....	<b>12-2</b>
Output Specifications .....	12-3
General Specifications .....	12-3
Analog Output Configuration Requirements .....	12-3
Special Placement Requirements (DL230 and Remote I/O Bases) .....	12-4
<b>Connecting the Field Wiring</b> .....	<b>12-5</b>
Wiring Guidelines .....	12-5
Loop Power Supply Requirements .....	12-5
Wiring Diagram .....	12-5
<b>Module Operation</b> .....	<b>12-6</b>
Channel Update Sequence (Multiplexing Method) .....	12-6
Channel Update Sequence (Pointer Method) .....	12-7
Understanding the Output Assignments .....	12-8
Channel Select .....	12-8
Outputs .....	12-8
Analog Data Bits .....	12-9

Module Resolution .....	12-9
<b>Writing the Control Program .....</b>	<b>12-10</b>
Calculating the Digital Value .....	12-10
Engineering Units Conversion .....	12-10
Reading Values: Pointer Method and Multiplexing .....	12-11
Pointer Method .....	12-11
Multiplexing .....	12-13
Sending Data to One Channel .....	12-14
Sending the Same Data to Both Channels .....	12-14
Analog and Digital Value Conversions .....	12-15

## Chapter 13: F2-02DAS-2 0-5, 0-10V 2-Channel Isolated Output

<b>Module Specifications .....</b>	<b>13-2</b>
Output Specifications .....	13-3
General Specifications .....	13-3
Analog Output Configuration Requirements .....	13-3
Special Placement Requirements (D2-230 and Remote I/O Bases) .....	13-4
<b>Setting the Module Jumpers .....</b>	<b>13-5</b>
<b>Connecting the Field Wiring .....</b>	<b>13-6</b>
Wiring Guidelines .....	13-6
Transmitter Power Supply Requirements .....	13-6
Wiring Diagram .....	13-6
<b>Module Operation .....</b>	<b>13-7</b>
Channel Update Sequence (Multiplexing Method) .....	13-7
Channel Update Sequence (Pointer Method) .....	13-8
Understanding the Output Assignments .....	13-8
Channel Select .....	13-9
Outputs .....	13-9
Analog Data Bits .....	13-9
Module Resolution .....	13-10
<b>Writing the Control Program .....</b>	<b>13-11</b>
Calculating the Digital Value .....	13-11
Engineering Units Conversion .....	13-11
Reading Values: Pointer Method and Multiplexing .....	13-12
Pointer Method .....	13-12
Multiplexing .....	13-14
Sending Data to One Channel .....	13-15
Sending the Same Data to Both Channels .....	13-15
Analog and Digital Value Conversions .....	13-16

## Chapter 14: F2-4AD2DA 4-Ch. In / 2-Ch. Out Combination Analog

<b>Module Specifications</b> .....	<b>14-2</b>
Input Specifications .....	14-2
Output Specifications .....	14-3
General Module Specifications .....	14-3
Combination Analog Configuration Requirements .....	14-3
Special Placement Requirements (DL230 and Remote I/O Bases) .....	14-4
<b>Connecting the Field Wiring</b> .....	<b>14-5</b>
Wiring Guidelines .....	14-5
User Power Supply Requirements .....	14-5
Current Loop Transmitter Impedance .....	14-6
Wiring Diagram .....	14-7
<b>Module Operation</b> .....	<b>14-8</b>
Input Channel Update Sequence with a DL230 CPU .....	14-8
Input Channel Scanning Sequence With a DL240/250-1/260 CPU .....	14-8
Output Channel Update Sequence with a DL230 CPU .....	14-9
Output Channel Update Sequence with a DL240/250-1/260 CPU .....	14-9
Understanding the I/O Assignments .....	14-10
Input Data Bits .....	14-10
Active Channel Indicator Inputs .....	14-11
Diagnostic Indicator Inputs .....	14-11
Output Data Bits .....	14-11
Output Channel Selection Bits .....	14-12
Module Resolution .....	14-12
<b>Writing the Control Program</b> .....	<b>14-13</b>
Analog Input Power Failure Detection .....	14-13
Calculating the Output Data .....	14-13
Scaling the InputData .....	14-15
Read / Write Program (Pointer Method) .....	14-16
Reading Input Values .....	14-18
Single Input Channel Selected .....	14-19
Writing Output Data .....	14-19
Sending Data to One Channel .....	14-20
Sending the Same Data to Both Channels .....	14-20
Analog and Digital Value Conversions .....	14-20
Filtering Input Noise (DL250-1/260 CPU Only) .....	14-21

## Appendix A: DL205 Discrete I/O Memory Map

<b>X Input / Y Output Bit Map</b> .....	<b>A-2</b>
<b>Control Relay Bit Map</b> .....	<b>A-4</b>
<b>Global I/O Bit Map</b> .....	<b>A-8</b>

# Getting Started

---

## In This Chapter. . . .

- Introduction
  - Conventions Used
  - Physical Characteristics
  - Analog Input Module Terminology
  - Analog Output Module Terminology
  - Selecting the Appropriate Module
  - Analog Made Easy - Four Simple Steps
-

## Introduction

### The Purpose of this Manual

This manual will show you how to select and install analog input and analog output modules. It also shows several ways to use the analog data in your PLC program. If you understand the DL205 instruction set and system setup requirements, this manual will provide the information you need to install and use the analog modules. This manual *is not* intended to be a tutorial on analog signal theory, but rather a user reference manual for the DL205 Analog I/O modules.

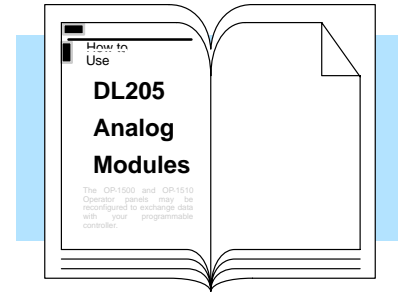

### Supplemental Manuals

You may also want to have a copy of the DL205 User Manual (D2-USER-M) at hand when you are working with the analog modules. The DL205 User Manual is not absolutely necessary, but it does provide detailed descriptions of the instructions used to acquire the analog data. The User Manual also provides a more thorough description of how the I/O points are assigned to the module. Now, you have the material necessary to quickly understand the DL205 Analog I/O modules. So, let's get started!

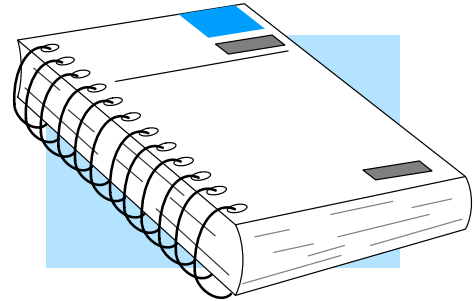

### Technical Support

We realize that even though we strive to be the best, we may have arranged our information in such a way you cannot find what you are looking for. First, check these resources for help in locating the information:

- **Table of Contents** – chapter and section listing of contents, in the front of this manual
- **Appendices** – reference material for key topics, near the end of this manual

You can also check our online resources for the latest product support information:

- **Internet** – Our address is <http://www.automationdirect.com>

If you still need assistance, please call us at 770-844-4200. Our technical support group is glad to work with you in answering your questions. They are available Monday through Friday from 9:00 A.M. to 6:00 P.M. Eastern Standard Time. If you have a comment or question about any of our products, services, or manuals, please fill out and return the 'Suggestions' card that was shipped with this manual.

## Conventions Used



When you see the “light bulb” icon in the left-hand margin, the paragraph to its immediate right will give you a **special tip**.

The word **TIP**: in boldface will mark the beginning of the text.



When you see the “notepad” icon in the left-hand margin, the paragraph to its immediate right will be a **special note**.

The word **NOTE**: in boldface will mark the beginning of the text.

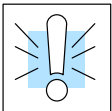

When you see the “exclamation mark” icon in the left-hand margin, the paragraph to its immediate right will be a **warning**. This information could prevent injury, loss of property, or even death (in extreme cases).

The word **WARNING**: in boldface will mark the beginning of the text.

### Key Topics for Each Chapter

The beginning of each chapter will list the key topics that can be found in that chapter.

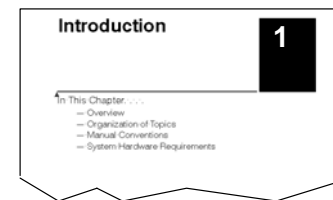

## Physical Characteristics

The DL205 Analog Modules provide many features that make the modules easy to use. With the exception of the Thermocouple module, the terminal blocks are removable, which makes wiring a simple task.

All of the DL205 analog modules have normal screw terminal connectors. Access the module terminals by removing the front cover (not shown). To remove the front cover, press the tab on the lower front corner of the cover. For ease of removal, most modules have squeeze tabs on the top and bottom. To remove the terminal block, press the tabs and pull the terminal block away from the module.

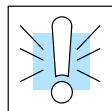

**WARNING:** For some modules, field device power may still be present on the terminal block even though the PLC system is turned off. To minimize the risk of electrical shock, check all field device power *before* you remove the connector.

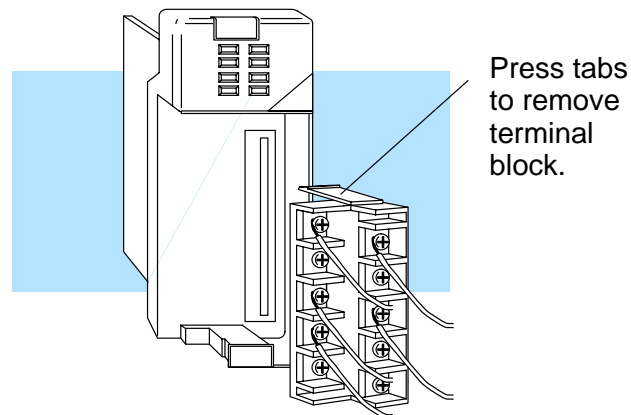

## Analog Input Module Terminology

We use several different terms throughout the rest of this manual. You do not have to be an expert on analog terms to use the products, but it may help make it easier to select the appropriate modules if you take a few minutes to review these definitions.

<b>Channels per Module</b>	The total number of analog signals the module receives from field devices.
<b>Input Ranges</b>	The minimum to maximum spans in voltage or current the module will successfully convert to digital values.
<b>Resolution</b>	The number of binary weighted bits available on the digital side of the module for use in converting the analog value to a digital value.
<b>Input Type</b>	Specifies if the module accepts single ended, or differential input signals.
<b>Input Impedance</b>	The resistive load of the module as seen by a voltage or current input signal.
<b>Conversion Method</b>	The method the module uses to convert the analog signal to a digital value.
<b>PLC Update Rate</b>	Speed at which the analog signals are digitized and acknowledged in the PLC.
<b>Linearity Error</b>	The relative accuracy of the digital representation over the entire input range.
<b>Maximum Inaccuracy</b>	Maximum absolute error of the digital representation of the signal over the entire input range. Factors which contribute to maximum inaccuracy are also specified separately. These factors are full-scale calibration error, offset calibration error, and accuracy vs. temperature.
<b>Accuracy vs. Temperature</b>	The variations in the module's conversion accuracy with temperature over the module's operating temperature range.
<b>I/O Points Required</b>	The number of I/O points the CPU must dedicate to the module.
<b>External Power Source</b>	Some modules require a separate 12VDC or 24VDC power source. The 24VDC output supply at the local base can be used as long as you do not exceed the current ratings of 300mA.
<b>Base Power Required</b>	The amount of base current required by the module. Use this value in your power budget calculations.
<b>Operating Temperature</b>	The minimum and maximum temperatures the module will operate within.
<b>Relative Humidity</b>	The minimum and maximum humidity the module will operate within.
<b>Step Response</b>	The time required for an analog input to reach 95% of its final value at the converter following a step change in the input signal level.

## Analog Output Module Terminology

<b>Channels per Module</b>	The total number of analog signals the module sends to field devices.
<b>Output Ranges</b>	The minimum to maximum spans in voltage or current the module outputs, converted from digital values.
<b>Resolution</b>	The number of binary weighted bits available on the digital side of the module for use in converting the digital value to an analog signal.
<b>Output Current</b>	The maximum current the module will drive using a voltage output signal.
<b>Output Impedance</b>	The output impedance of the module using a voltage output signal.
<b>Load Impedance</b>	The minimum and maximum resistance the module can drive, specified for current and voltage output signals.
<b>PLC Update Rate</b>	The speed at which digital values in the PLC are converted to analog output signals.
<b>Linearity Error</b>	The relative accuracy of the digital representation over the entire output range.
<b>Maximum Inaccuracy</b>	Maximum absolute error of the digital representation of the signal over the entire output range. Factors which contribute to maximum inaccuracy are also specified separately. These factors are full-scale calibration error, offset calibration error, and accuracy vs temperature.
<b>Accuracy vs. Temperature</b>	The variations in the module's conversion accuracy with temperature over the module's operating temperature range.
<b>External Power Source</b>	All output modules contain circuitry which is optically isolated from PLC-side logic. That circuitry requires field-side power from a separate 24VDC power source. The 24VDC output supply at the local base can be used as long as you do not exceed the current ratings.
<b>Base Power Required</b>	The amount of base current required by the module. Use this value in your power budget calculations.
<b>Operating Temperature</b>	The minimum and maximum temperatures the module will operate within.
<b>Relative Humidity</b>	The range of air humidity over which the module will operate properly.
<b>I/O Points Required</b>	The number of I/O points the CPU must dedicate to the module.

## Selecting the Appropriate Module

### Wide Variety of Modules

There are a wide variety of Analog I/O modules available for use with the DL205 family of automation products. These modules are well suited for monitoring and controlling various types of analog signals such as pressure, temperature, etc. No complex programming or module setup software is required. Simply install the module, add a few lines to your RLL program, and you're ready!

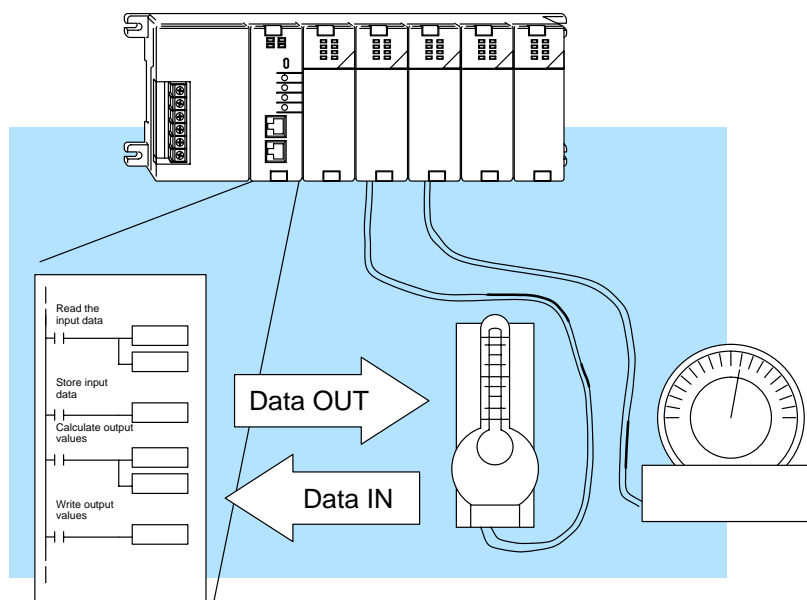

Analog input, temperature input and analog output modules are available. These modules are designed and manufactured by FACTS Engineering. FACTS has been producing feature-packed products for the **Direct**LOGIC families (and compatible products) for years! These modules are readily identifiable by their F2- prefix in the part number.

### Diagnostic Features

The DL205 Analog Modules use an on-board microcontroller that automatically monitors module diagnostics. You can easily detect missing field-side supply 24 VDC voltage or a loose terminal block.

The following tables provide a condensed version of the information you need to select the appropriate module. The most important thing is to simply determine the number of channels required and the signal ranges that must be supported. Once you've determined these parameters, look in the specific chapter for the selected module to determine the installation and operation requirements.

**Analog Input**

Specification	F2-04AD-1, (L)	F2-04AD-2, (L)	F2-08AD-1	F2-08AD-2
Channels	4	4	8	8
Input Ranges	4 – 20 mA	0 – 5V, 0 – 10V, –5 to +5V, –10 to +10V	4 – 20 mA	0 – 5V, 0 – 10V, –5 to +5V, –10 to +10V
Resolution	12 bit (1 in 4096)	12 bit (1 in 4096), and 13 bit (1 in 8192)	12 bit (1 in 4096)	12 bit (1 in 4096), and 13 bit (1 in 8192)
Input Type	Single ended	Single ended	Single ended	Single ended
Maximum Inaccuracy	± 0.5% at 25 °C (77 °F ), ± 0.65% at 0° – 60° C (32° – 140° F)	± 0.1% at 25 °C (77 °F ), ± 0.3% at 0° – 60° C (32° – 140° F)	± 0.1% at 25 °C (77 °F ), ± 0.25% at 0° – 60° C (32° – 140° F)	± 0.1% at 25 °C (77 °F ), ± 0.3% at 0° – 60° C (32° – 140° F)
See Chapter...	2	3	4	5

**Special Input**

Specification	F2-04RTD	F2-04THM
Input Channels	4	4
Resolution	24 bit internal	16 bit voltage ranges 24 bit Internal
Input Ranges	Pt100Ω, -200.0 – 850.0 °C (-328 – 1562 °F) Pt1000Ω, -200.0 – 595.0 °C (-328 – 1103 °F) jPt100Ω, -38.0 – 450.0 °C (-36 – 842 °F) Cu. 25Ω, Cu. 10Ω -200.0 – 260.0 °C (-328 – 500 °F)	Type J -190 – 760°C E -210 – 1000°C K -150 – 1372°C R 65 – 1768°C S 65 – 1768°C T -230 – 400°C B 529 – 1820°C N -70 – 1300°C C 65 – 2320°C Voltage Ranges 0–5 VDC ± 5 VDC 0–156mVDC ± 156mVDC
Input Type	Differential	Differential
Maximum Input Inaccuracy	± 1.0°C	± 3.0°C Temperature ± 0.02% Voltage
See Chapter...	6	7

## Analog Output

Specification	F2-02DA-1, (L)	F2-02DA-2, (L)
Channels	2	2
Output Ranges	4 – 20 mA	0 – 5V, 0 – 10V, –5 to +5V, –10 to +10V
Resolution	12 bit (1 in 4096)	12 bit (1 in 4096)
Output Type	Single ended	Single ended
See Chapter...	8	9

Specification	F2-08DA-1	F2-08DA-2
Channels	8	8
Output Ranges	4 – 20mA	0 – 5V, 0 – 10V
Resolution	12 bit (1 in 4096)	16 bit (1 in 4096)
Output Type	Single ended	Single ended, 1 common
See Chapter...	10	11

Specification	F2-02DAS-1	F2-02DAS-2
Channels	2	8
Output Ranges	4 – 20mA	0 – 5V, 0 – 10V
Resolution	16 bit (1 in 65536)	16 bit (1 in 65536)
Output Type	Current sourcing	Isolated
See Chapter...	12	13

Combination  
Analog

Specification	F2-4AD2DA
Input Channels	4
Output Channels	2
Input Ranges	4 – 20 mA
Output Ranges	4 – 20 mA
Resolution	12 bit (1 in 4096)
Channel Isolation	Non-isolated (one common)
Input and Output Types	Single ended
Maximum Input Inaccuracy	$\pm 0.3\%$ at 25 °C (77 °F ) $\pm 0.45\%$ at 0° – 60° C (32° – 140° F)
Maximum Output Inaccuracy	$\pm 0.1\%$ at 25 °C (77 °F ) $\pm 0.3\%$ at 0° – 60° C (32° – 140° F)
See Chapter . . . .	14

# Analog Made Easy – Four Simple Steps

Once you have selected the appropriate module, use the chapter that describes that module and complete the following steps.

Step 1. Take a minute to review the detailed specifications to make sure the module meets your application requirements.

Specification		
Channels	2	2
Output Ranges	4 – 20 mA	0 – 5V 0 – 10V –5 – +5V –10 – +10V
Resolution	12 bit (1 in 4096)	12 bit (1 in 4096)
Channel Isolation	Non-Isolated	Non-Isolated
Output Type	Single ended	Single ended
Maximum Inaccuracy at 25 °C (77 °F)	± 0.1%	± 0.3% unipolar ± 0.4% bipolar
at 0° – 25° C (32° – 140° F)	± 0.3%	
See Chapter . . .	4	5

Step 2. If applicable, set the module switches and/or jumpers to select:

- number of channels
- the operating ranges

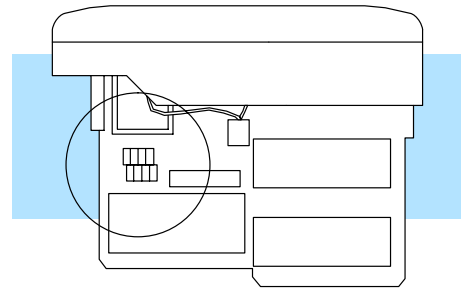

Step 3. Connect the field wiring to the module connector.

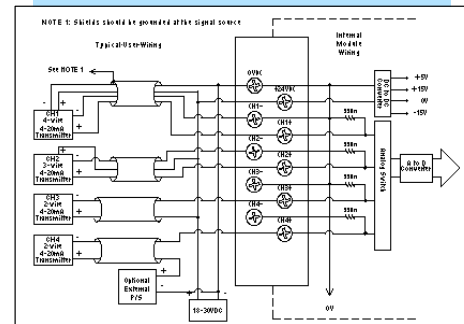

Step 4. Review the module operating characteristics and write the control program.

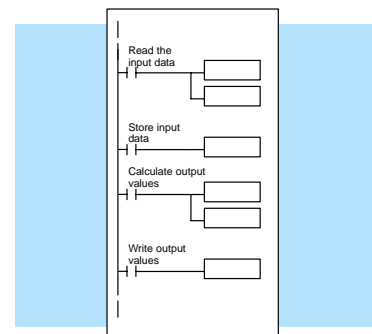

# **F2-04AD-1, F2-04AD-1L 4-Channel Analog Current Input**

---

In This Chapter. . . .

- Module Specifications
  - Setting the Module Jumpers
  - Connecting the Field Wiring
  - Module Operation
  - Writing the Control Program
-

## Module Specifications

The F2-04AD-1 (24 VDC input power model) and F2-04AD-1L (12 VDC input power model) Analog Input modules provide several hardware features.

- On-board 250 ohm, 1/2 watt precision resistors provide substantial over-current-protection for 4–20mA current loops.
- Analog inputs are optically isolated from the PLC logic.
- The module has a removable terminal block so the module can be easily removed or changed without disconnecting the wiring.
- With a DL240/250–1/260 CPU, you can read all four channels in one scan.
- On-board active analog filtering and RISC-like microcontroller provide digital signal processing to maintain precision analog measurements in noisy environments.
- F2-04AD-1: Low-power CMOS design requires less than 80mA from an external 18–30 VDC power supply.
- F2-04AD-1L: Low-power CMOS design requires less than 90mA from an external 10–15 VDC power supply.

**NOTE:** These two modules look very similar and it is very easy to mistake one module for the other. If your module does not work, check the terminal label to see if you have a 12 volts (L) or 24 volts model and that it is being supplied with the proper input voltage.

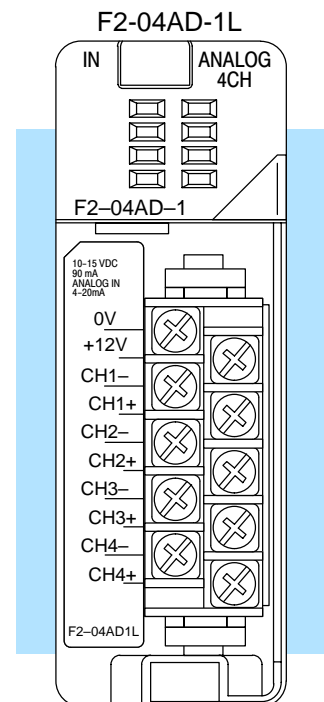
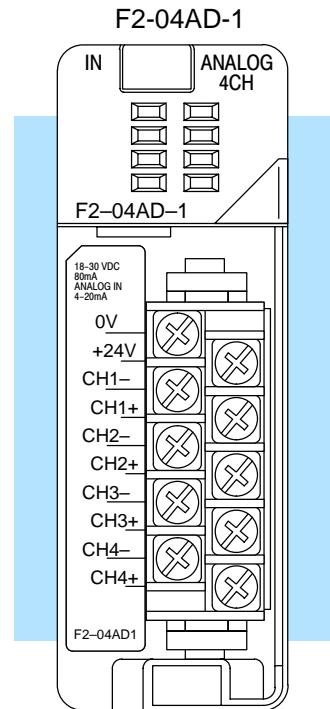

The following tables provide the specifications for both the F2-04AD-1 and F2-04AD-1L Analog Input Modules (all specifications are the same for both modules except for the input voltage requirements). Review these specifications to make sure the module meets your application requirements.

### Input Specifications

Number of Channels	4, single ended (one common)
Input Range	4 to 20 mA current
Resolution	12 bit (1 in 4096)
Step Response	4.0 mS to 95% of full step change
Crosstalk	-80 dB, 1/2 count maximum
Active Low-pass Filtering	-3 dB at 80Hz, 2 poles (-12 dB per octave)
Input Impedance	250Ω ± 0.1%, ½W current input
Absolute Maximum Ratings	-40 mA to +40 mA, current input
Converter type	Successive approximation
Linearity Error (End to End)	± 1 count (0.025% of full scale) maximum
Input Stability	± 1 count
Full Scale Calibration Error (Offset error not included)	± 12 counts maximum, @ 20mA current input
Offset Calibration Error	± 7 counts maximum, @ 4mA current input
Maximum Inaccuracy	± .5% @ 25°C (77°F) ± .65% 0 to 60°C (32 to 140°F)
Accuracy vs. Temperature	± 50 ppm/°C maximum full scale calibration (including maximum offset change)
Recommended Fuse (external)	0.032 A, Series 217 fast-acting, current inputs

### General Specifications

PLC Update Rate	1 channel per scan maximum (DL230 CPU) 4 channels per scan maximum (DL240/250-1/260 CPU)
Digital Inputs Input points required	12 binary data bits, 2 channel ID bits, 2 diagnostic bits 16 point (X) input module
Power Budget Requirement	50 mA maximum, 5 VDC (supplied by base)
External Power Supply	80 mA maximum, 18 to 30 VDC (F2-04AD-1) 90 mA maximum, 10 to 15 VDC (F2-04AD-1L)
Operating Temperature	0 to 60° C (32 to 140° F)
Storage Temperature	-20 to 70° C (-4 to 158° F)
Relative Humidity	5 to 95% (non-condensing)
Environmental air	No corrosive gases permitted
Vibration	MIL STD 810C 514.2
Shock	MIL STD 810C 516.2
Noise Immunity	NEMA ICS3-304

One count in the specification table is equal to one least significant bit of the analog data value (1 in 4096).

### Analog Input Configuration Requirements

The F2-04AD-1, (L) Analog Input appears as a 16-point discrete input module. The module can be installed in any slot of a DL205 system. The available power budget and discrete I/O points are the limiting factors. Check the user manual for your particular model of CPU and I/O base for more information regarding power budget and number of local, local expansion or remote I/O points.

**Special Placement Requirements (DL230 and Remote I/O Bases)**

Even though the module can be placed in any slot, it is important to examine the configuration if you are using a DL230 CPU. As you can see in the section on writing the program, you use V-memory locations to extract the analog data. If you place the module so that the input points do not start on a V-memory boundary, the instructions cannot access the data. This also applies when placing this module in a remote base using a D2-RSSS in the CPU slot.

F2-04AD-1, (L)  
4-Ch. Current Input

**Correct!**

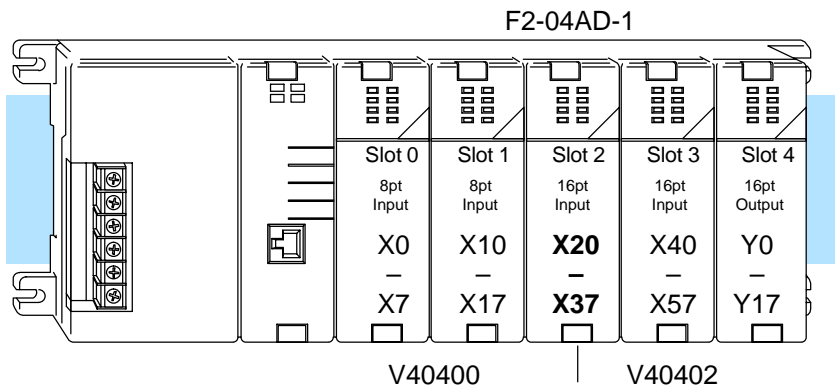

Data is correctly entered so input points start on a V-memory boundary.

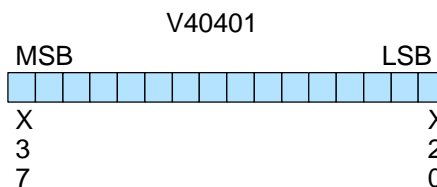

**Incorrect**

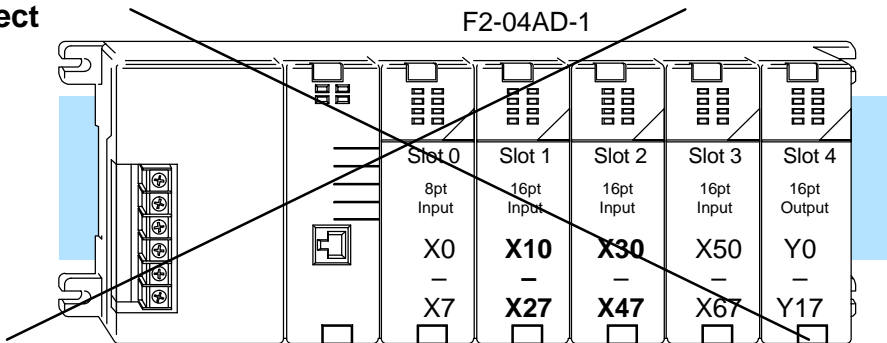

Data is split over two locations, so instructions cannot access data from a DL230.

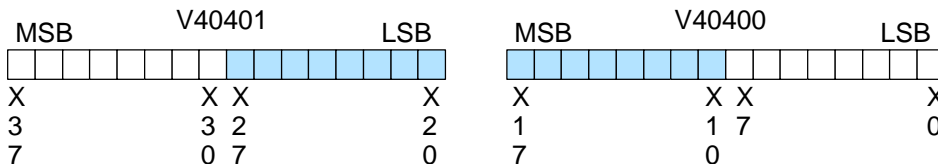

To use the V-memory references required for a DL230 CPU, the *first* input address assigned to the module must be one of the following X locations. The table also shows the V-memory addresses that correspond to these X locations.

<b>X</b>	X0	X20	X40	X60	X100	X120	X140	X160
<b>V</b>	V40400	V40401	V40402	V40403	V40404	V40405	V40406	V40407

## Setting the Module Jumpers

### Selecting the Number of Channels

There are two jumpers, labeled +1 and +2, that are used to select the number of channels that will be used. These jumpers are located on the motherboard, the one *with* the black D-shell style backplane connector. The module is set from the factory for four channel operation.

Any unused channels are not processed, so if you only select channels 1 thru 3, channel 4 will not be active. The following table shows how to use the jumpers to select the number of channels.

No. of Channels	+1	+2
1	No	No
1, 2	Yes	No
1, 2, 3	No	Yes
1, 2, 3, 4	Yes	Yes

Yes = jumper installed

No = jumper removed

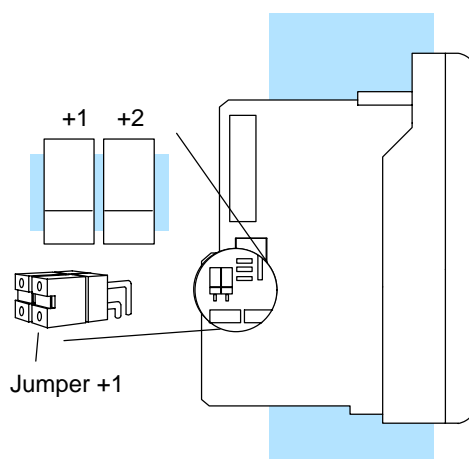

For example, to select all 4 channels (1 – 4), leave both jumpers installed. To select channel 1, remove both jumpers.

## Connecting the Field Wiring

**Wiring Guidelines** Your company may have guidelines for wiring and cable installation. If so, you should check those before you begin the installation. Here are some general things to consider:

- Use the shortest wiring route whenever possible.
- Use shielded wiring and ground the shield at the transmitter source. *Do not* ground the shield at both the module and the source.
- Do not run the signal wiring next to large motors, high current switches, or transformers. This may cause noise problems.
- Route the wiring through an approved cable housing to minimize the risk of accidental damage. Check local and national codes to choose the correct method for your application.

### User Power Supply Requirements

The module requires at least one field-side power supply. You may use the same or separate power sources for the module supply and the current transmitter supply. The F2-04AD-1 module requires 18–30VDC, at 80 mA. The DL205 bases have built-in 24 VDC power supplies that provide up to 300mA of current. You may use this with F2-04AD-1 modules instead of a separate supply if you are using only a couple of analog modules.

It is desirable in some situations to power the transmitters separately in a location remote from the PLC. This will work as long as the transmitter supply meets the voltage and current requirements, and the transmitter's minus (-) side and the module supply's minus (-) side are connected together.

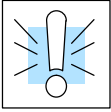

**WARNING:** If you are using the 24 VDC base power supply, make sure you calculate the power budget. Exceeding the power budget can cause unpredictable system operation that can lead to a risk of personal injury or damage to equipment.

The DL205 base has a switching type power supply. As a result of switching noise, you may notice  $\pm 3$ –5 counts of instability in the analog input data if you use the base power supply. If this is unacceptable, you should try one of the following:

1. Use a separate linear power supply.
2. Connect the 24VDC common to the frame ground, which is the screw terminal marked "G" on the base.

By using these methods, the input stability is rated at  $\pm 1$  count.

The F2-04AD-1L module requires 10–15VDC, at 90 mA and must be powered by a separate power supply.

### Current Loop Transmitter Impedance

Standard 4 to 20 mA transmitters and transducers can operate from a wide variety of power supplies. Not all transmitters are alike and the manufacturers often specify a minimum loop or load resistance that must be used with the transmitter.

The F2-04AD-1, (L) provides 250 ohm resistance for each channel. If your transmitter requires a load resistance below 250 ohms, you do not have to make any adjustments. However, if your transmitter requires a load resistance higher than 250 ohms, you need to add a resistor in series with the module.

Consider the following example for a transmitter being operated from a 30 VDC supply with a recommended load resistance of 750 ohms. Since the module has a 250 ohm resistor, you need to add an additional resistor.

$$R = Tr - Mr$$

$$R = 750 - 250$$

$$R \geq 500$$

R – resistor to add  
Tr – Transmitter Requirement  
Mr – Module resistance (internal 250 ohms)

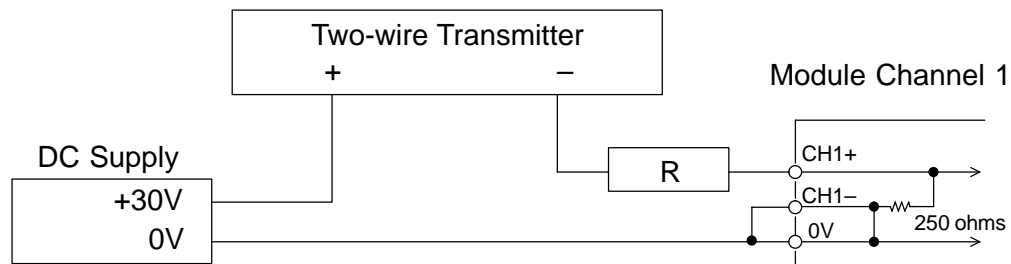

**Wiring Diagram**

The F2-04AD-1, (L) module has a removable connector to make wiring easier. Simply squeeze the top and bottom retaining clips and gently pull the connector from the module. Use the following diagram to connect the field wiring. The diagram shows separate module and transmitter power supplies. If you desire to use only one field-side supply, just combine the supplies' positive (+) terminals into one node, and remove the transmitter supply.

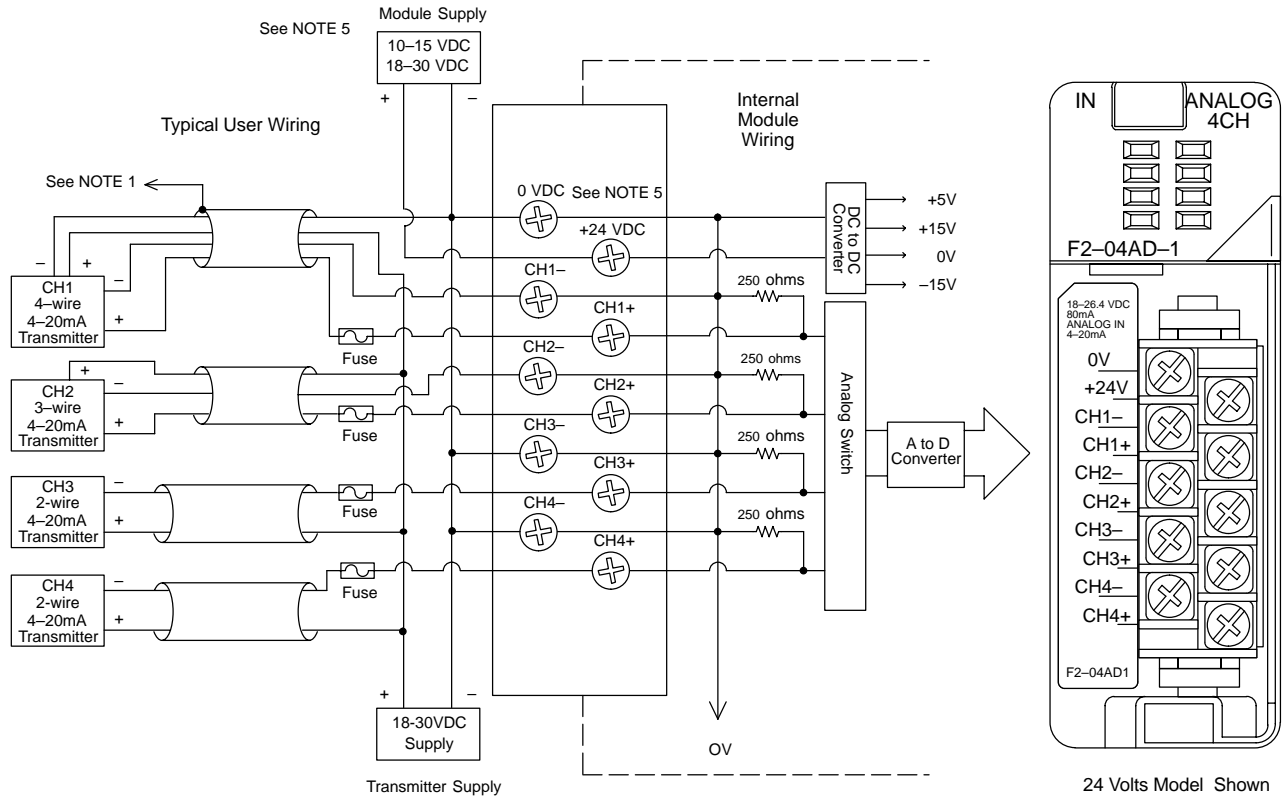

- NOTE 1: Shields should be grounded at the signal source.
- NOTE 2: More than one external power supply can be used, provided all the power supply commons are connected.
- NOTE 3: A Series 217, 0.032A fast-acting fuse is recommended for 4-20 mA current loops.
- NOTE 4: If the power supply common of an external power supply is not connected to 0VDC on the module, then the output of the external transmitter must be isolated. To avoid "ground loop" errors, recommended 4-20 mA transmitter types are:
  - 2 or 3 wire: Isolation between input signal and power supply.
  - 4 wire: Isolation between input signal, power supply, and 4-20mA output.
- NOTE 5: Use 10-15VDC for F2-04AD-1L  
Use 18-30VDC for F2-04AD-1

F2-04AD-1, (L)  
4-Ch. Current Input

# Module Operation

## Channel Scanning Sequence for a DL230 CPU (Multiplexing)

Before you begin writing the control program, it is important to take a few minutes to understand how the module processes and represents the analog signals.

The module can supply different amounts of data per scan, depending on the type of CPU you are using. The DL230 can obtain one channel of data per CPU scan. Since there are four channels, it can take up to four scans to get data for all channels. Once all channels have been scanned the process starts over with channel 1. Unused channels are not processed, so if you select only two channels, then each channel will be updated every other scan. The multiplexing method can also be used for the DL240/250-1 and DL260 CPUs.

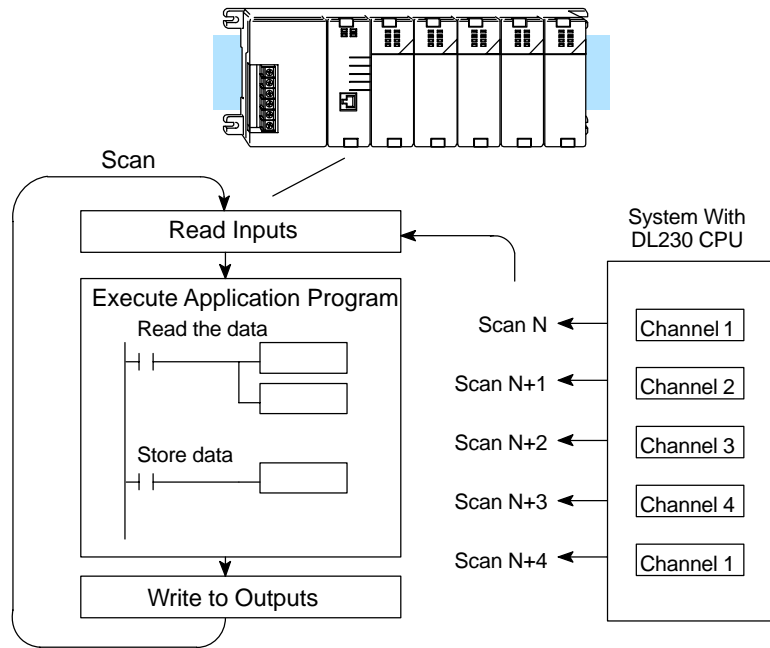

F2-04AD-1, (L)  
4-Ch. Current Input

### Channel Scanning Sequence for a DL240, DL250-1 or DL260 CPU (Pointer Method)

If you are using a DL240/250-1/260 CPU, you can obtain all four channels of input data in one scan. This is because the DL240/250-1/260 CPU supports special V-memory locations that are used to manage the data transfer. This is discussed in more detail in the section on Writing the Control Program.

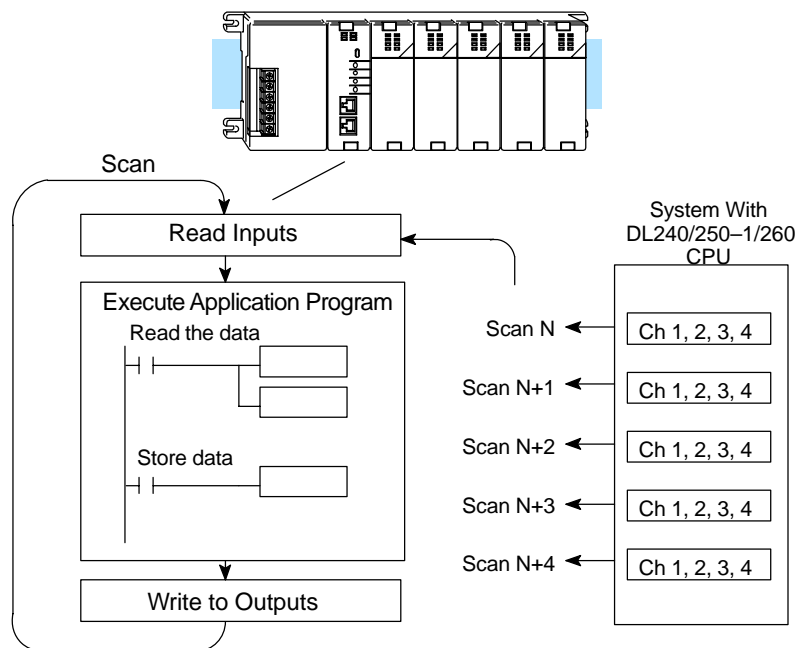

### Analog Module Updates

Even though the channel updates to the CPU are synchronous with the CPU scan, the module asynchronously monitors the analog transmitter signal and converts the signal to a 12-bit binary representation. This enables the module to continuously provide accurate measurements without slowing down the discrete control logic in the RLL program.

For the vast majority of applications, the values are updated much faster than the signal changes. However, in some applications, the update time can be important. The module takes approximately 4 milliseconds to sense 95% of the change in the analog signal.

Note, this is *not* the amount of time required to convert the signal to a digital representation. The conversion to the digital representation takes only a few microseconds. Many manufacturers list the conversion time, but it is the settling time of the filter that really determines the update time.

### Understanding the Input Assignments

You may recall the F2-04AD-1, (L) module requires 16 discrete input points in the CPU. You can use these points to obtain:

- an indication of which channel is active
- the digital representation of the analog signal
- module diagnostic information

Since all input points are automatically mapped into V-memory, it is very easy to determine the location of the data word that will be assigned to the module.

F2-04AD-1, (L)  
4-Ch. Current Input

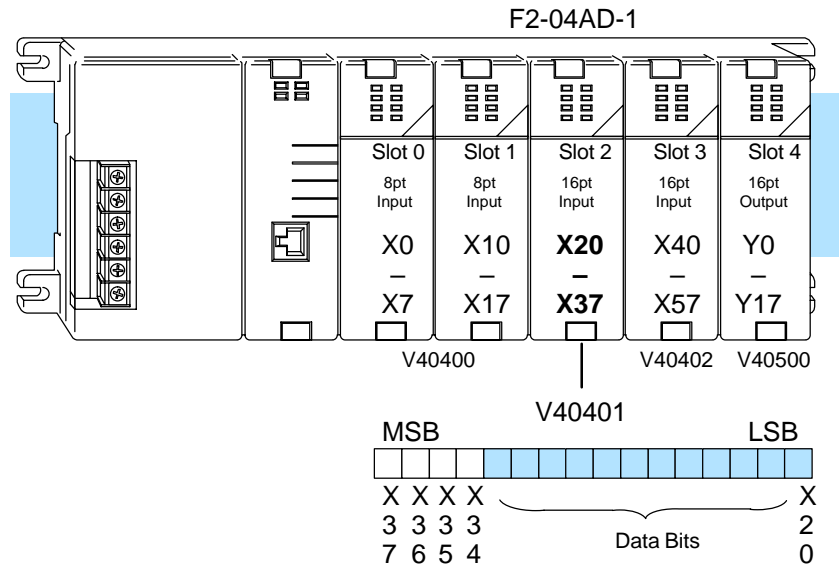

Within these word locations, the individual bits represent specific information about the analog signal.

### Analog Data Bits

The first twelve bits represent the analog data in binary format.

Bit	Value	Bit	Value
0	1	6	64
1	2	7	128
2	4	8	256
3	8	9	512
4	16	10	1024
5	32	11	2048

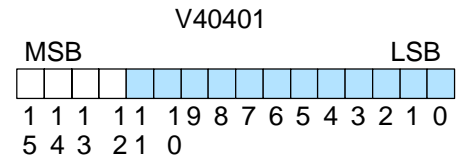

= data bits

**Active Channel Indicator Inputs**

Two of the inputs are binary-encoded to indicate the active channel (remember, the V-memory bits are mapped directly to discrete inputs). The inputs are automatically turned on and off to indicate the active channel for each scan.

Scan	X35	X34	Channel
N	Off	Off	1
N+1	Off	On	2
N+2	On	Off	3
N+3	On	On	4
N+4	Off	Off	1

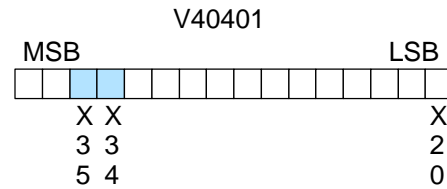

= channel inputs

**Module Diagnostic Inputs**

The last two inputs are used for module diagnostics.

**Module Busy** — The first diagnostic input (X36 in this example) indicates a “busy” condition. This input will always be active on the first PLC scan, to tell the CPU the analog data is not valid. After the first scan, the input usually only comes on when extreme environmental (electrical) noise problems are present. The programming examples in the next section shows how you can use this input. The wiring guidelines shown earlier in this chapter provide steps that can help reduce noise problems.

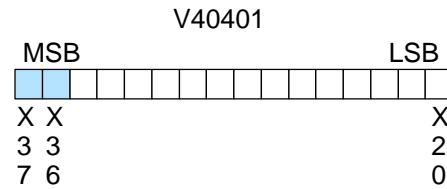

= diagnostic inputs

**Note:** When using the pointer method, the value placed into the V-memory location will be 8000 instead of the bit being set.

**Channel Failure** — The last diagnostic input (X37 in this example) indicates the analog channel is not operating. For example, if the 24 VDC input power is missing or if the terminal block is loose, the module will turn on this input point. The module also returns a data value of zero to further indicate there is a problem.

The next section, Writing the Control Program, shows how you can use these inputs in your control program.

**Module Resolution**

Since the module has 12-bit resolution, the analog signal is converted into 4096 counts ranging from 0 – 4095 (2<sup>12</sup>). For example, a 4mA signal would be 0 and a 20mA signal would be 4095. This is equivalent to a binary value of 0000 0000 to 1111 1111 1111, or 000 to FFF hexadecimal. The diagram shows how this relates to the signal range.

Each count can also be expressed in terms of the signal level by using the equation shown.

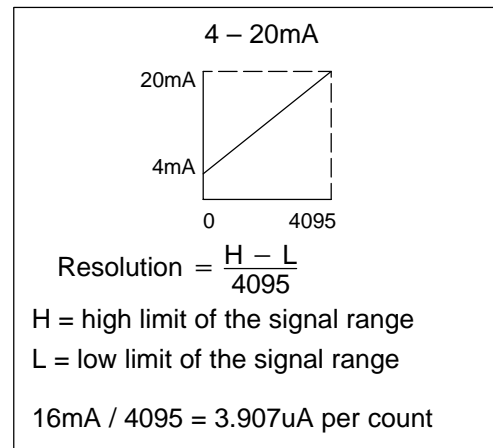

## Writing the Control Program

### Reading Values: Pointer Method and Multiplexing

There are two methods of reading values:

- The pointer method
- Multiplexing

You *must* use the multiplexing method when using a DL230 CPU. You must also use the multiplexing method with remote I/O modules (the pointer method will not work). You can use either method when using DL240, DL250-1 and DL260 CPUs, but for ease of programming it is strongly recommended that you use the pointer method.

The DL205 series has special V-memory locations assigned to each base slot that greatly simplify the programming requirements. These V-memory locations allow you to:

- specify the data format
- specify the number of channels to scan
- specify the storage locations

### Pointer Method

×	✓	✓	✓
230	240	250-1	260



**NOTE:** DL250 CPUs with firmware release version 1.06 or later support this method. If you must use the DL230 example, module placement in the base is very important. Review the section earlier in this chapter for guidelines.

The example program shows how to setup these locations. Place this rung anywhere in the ladder program, or in the initial stage if you are using stage programming instructions. This is all that is required to read the data into V-memory locations. Once the data is in V-memory you can perform math on the data, compare the data against preset values, and so forth. V2000 is used in the example but you can use any user V-memory location. In this example the module is installed in slot 2. You should use the V-memory locations for your module placement. The pointer method automatically converts values to BCD.

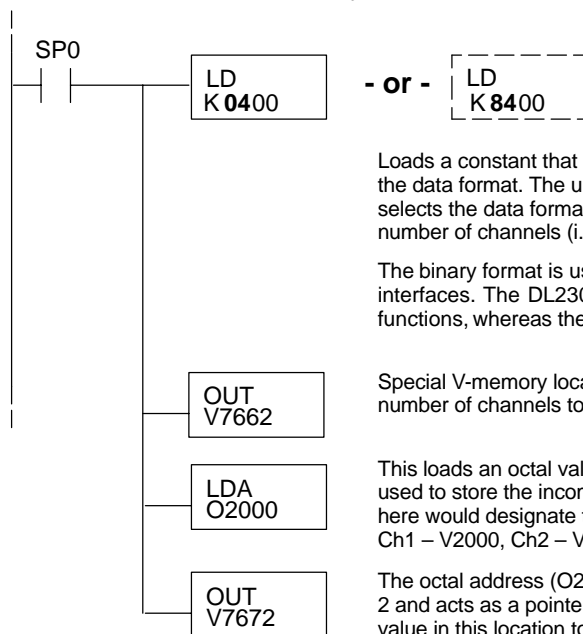

- or -

Loads a constant that specifies the number of channels to scan and the data format. The upper byte, most significant nibble (MSN) selects the data format (i.e. 0=BCD, 8=Binary), the LSN selects the number of channels (i.e. 1, 2, 3, or 4).

The binary format is used for displaying data on some operator interfaces. The DL230/240 CPUs do not support binary math functions, whereas the DL250 does.

Special V-memory location assigned to slot 2 that contains the number of channels to scan.

This loads an octal value for the first V-memory location that will be used to store the incoming data. For example, the O2000 entered here would designate the following addresses.  
Ch1 – V2000, Ch2 – V2001, Ch3 – V2002, Ch 4 – V2003

The octal address (O2000) is stored here. V7672 is assigned to slot 2 and acts as a pointer, which means the CPU will use the octal value in this location to determine exactly where to store the incoming data.

The tables below show the special V-memory locations used by the DL240, DL250-1 and DL260 for the CPU base and local expansion base I/O slots. Slot 0 (zero) is the module next to the CPU or D2-CM module. Slot 1 is the module two places from the CPU or D2-CM, and so on. Remember, the CPU only examines the pointer values at these locations after a mode transition. Also, if you use the DL230 (multiplexing) method, verify that these addresses in the CPU are zero.

The Table below applies to the DL240, DL250-1 and DL260 CPU base.

<b>CPU Base: Analog Input Module Slot-Dependent V-memory Locations</b>								
Slot	0	1	2	3	4	5	6	7
No. of Channels	V7660	V7661	V7662	V7663	V7664	V7665	V7666	V7667
Storage Pointer	V7670	V7671	V7672	V7673	V7674	V7675	V7676	V7677

The Table below applies to the DL250-1 or DL260 expansion base 1.

<b>Expansion Base D2-CM #1: Analog Input Module Slot-Dependent V-memory Locations</b>								
Slot	0	1	2	3	4	5	6	7
No. of Channels	V36000	V36001	V36002	V36003	V36004	V36005	V36006	V36007
Storage Pointer	V36010	V36011	V36012	V36013	V36014	V36015	V36016	V36017

The Table below applies to the DL250-1 or DL260 expansion base 2.

<b>Expansion Base D2-CM #2: Analog Input Module Slot-Dependent V-memory Locations</b>								
Slot	0	1	2	3	4	5	6	7
No. of Channels	V36100	V36101	V36102	V36103	V36104	V36105	V36106	V36107
Storage Pointer	V36110	V36111	V36112	V36113	V36114	V36115	V36116	V36117

The Table below applies to the DL260 CPU expansion base 3.

<b>Expansion Base D2-CM #3: Analog Input Module Slot-Dependent V-memory Locations</b>								
Slot	0	1	2	3	4	5	6	7
No. of Channels	V36200	V36201	V36202	V36203	V36204	V36205	V36206	V36207
Storage Pointer	V36210	V36211	V36212	V36213	V36214	V36215	V36216	V36217

The Table below applies to the DL260 CPU expansion base 4.

<b>Expansion Base D2-CM #4: Analog Input Module Slot-Dependent V-memory Locations</b>								
Slot	0	1	2	3	4	5	6	7
No. of Channels	V36300	V36301	V36302	V36303	V36304	V36305	V36306	V36307
Storage Pointer	V36310	V36311	V36312	V36313	V36314	V36315	V36316	V36317

### Reading Values (Multiplexing)

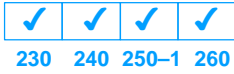

The DL230 CPU *does not* have the special V-memory locations that allow you to automatically enable the data transfer. Since all channels are multiplexed into a single data word, the control program must be setup to determine which channel is being read. Since the module appears as X input points to the CPU, it is very easy to use the active channel status bits to determine which channel is being monitored.

Note, this example is for a module installed as shown in the previous examples. The addresses used would be different if the module was installed in a different I/O arrangement. You can place these rungs anywhere in the program, or if you are using stage programming place them in a stage that is always active.

#### Load Data when Module is not busy

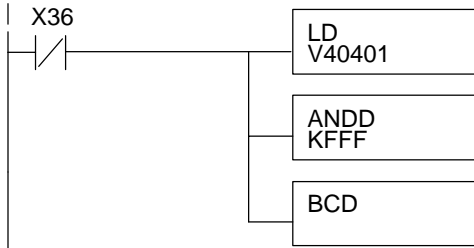

Loads the complete data word into the accumulator. The V-memory location depends on the I/O configuration. See Appendix A for the memory map.

This instruction masks the channel identification bits. Without this, the values used will not be correct so do not forget to include it.

It is usually easier to perform math operations in BCD, so it is best to convert the data to BCD immediately. You can leave out this instruction if your application does not require it.

#### Store Channel 1

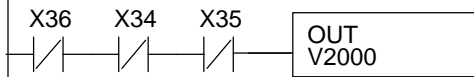

When the module is not busy and X34 and X35 are off, channel 1 data is stored in V2000.

#### Store Channel 2

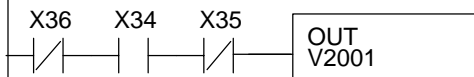

When X34 is on and X35 is off, channel 2 data is stored in V2001.

#### Store Channel 3

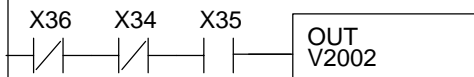

When X34 is off and X35 is on, channel 3 data is stored in V2002.

#### Store Channel 4

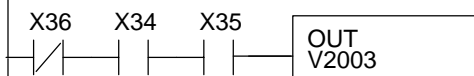

When both X34 and X35 are on, channel 4 data is stored in V2003.

**Single Channel Selected**

Since you do not have to determine which channel is selected, the single channel program is even more simple.

**Store Channel 1 when Module is not busy**

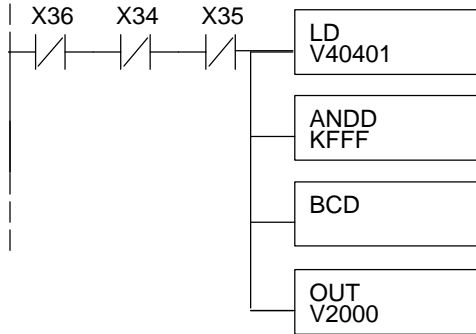

Loads the complete data word into the accumulator. The V-memory location depends on the I/O configuration. See Appendix A for the memory map.

This instruction masks the channel identification bits. Without this, the values used will not be correct so do not forget to include it.

It is usually easier to perform math operations in BCD, so it is best to convert the data to BCD immediately. You can leave out this instruction if your application does not require it.

When the module is not busy and X34 and X35 are off, channel 1 data is stored in V2000.

**Analog Power Failure Detection**

The Analog module has an on-board processor that can diagnose analog input circuit problems. You can easily create a simple ladder rung to detect these problems. This rung shows an input point that would be assigned if the module was installed as shown in the previous examples. A different point would be used if the module was installed in a different I/O arrangement.

**Multiplexing method**

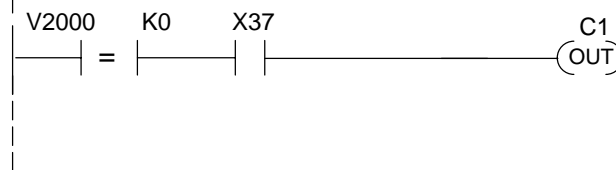

V-memory location V2000 holds channel 1 data. When a data value of zero is returned and input X37 is on, then the analog circuitry is not operating properly.

**Pointers method**



V-memory location V2000 holds channel 1 data. When a data value of 8000 is returned, then the analog circuitry is not operating properly.

**Scaling the Input Data**

Most applications usually require measurements in engineering units, which provides more meaningful data. This is accomplished by using the conversion formula shown.

You may have to make adjustments to the formula depending on the scale you choose for the engineering units.

$$\text{Units} = A \frac{H - L}{4095}$$

H = High limit of the engineering unit range

L = Low limit of the engineering unit range

A = Analog value (0 – 4095)

For example, if you wanted to measure pressure (PSI) from 0.0 to 99.9 then you would have to multiply the analog value by 10 in order to imply a decimal place when you view the value with the programming software or a handheld programmer. Notice how the calculations differ when you use the multiplier.

F2-04AD-1, (L)  
4-Ch. Current Input

Analog Value of 2024, slightly less than half scale, should yield 49.4 PSI

Example without multiplier

$$\text{Units} = A \frac{H - L}{4095}$$

$$\text{Units} = 2024 \frac{100 - 0}{4095}$$

$$\text{Units} = 49$$

Handheld Display

V 2001	V 2000
0000	0049

Example with multiplier

$$\text{Units} = 10 A \frac{H - L}{4095}$$

$$\text{Units} = 20240 \frac{100 - 0}{4095}$$

$$\text{Units} = 494$$

Handheld Display

V 2001	V 2000
0000	0494

This value is more accurate

The following example shows how you would write the program to perform the engineering unit conversion. This example assumes you have BCD data loaded into the appropriate V-memory locations using instructions that apply for the model of CPU you are using.

Note: this example uses SP1, which is always on. You could also use an X, C, etc. permissive contact.

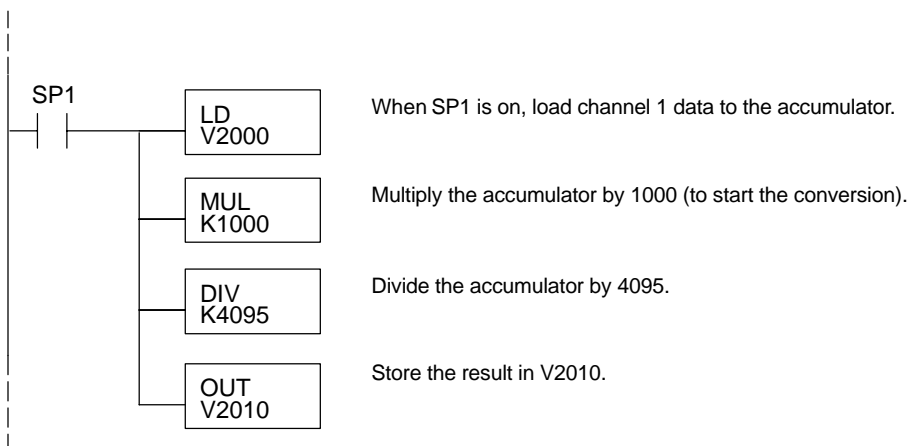

### Analog and Digital Value Conversions

Sometimes it is useful to be able to quickly convert between the signal levels and the digital values. This is especially helpful during machine startup or troubleshooting. The following table provides formulas to make this conversion easier.

Range	If you know the digital value...	If you know the analog signal level...
4 to 20mA	$A = \frac{16D}{4095} + 4$	$D = \frac{4095}{16}(A - 4)$

For example, if you have measured the signal as 10mA, you can use the formula to easily determine the digital value that will be stored in the V-memory location that contains the data.

$$D = \frac{4095}{16}(A - 4)$$

$$D = \frac{4095}{16}(10\text{mA} - 4)$$

$$D = (255.93) (6)$$

$$D = 1536$$

**Filtering Input Noise (DL250-1, DL260 CPU Only)**

X	X	✓	✓
230	240	250-1	260



Add the following logic to filter and smooth analog input noise in DL250-1 and DL260 CPUs. This is especially useful when using PID loops. Noise can be generated by the field device and/or induced by field wiring.

The analog value in BCD is first converted to a binary number because there is not a BCD-to-real conversion instruction. Memory location V1400 is the designated work space in this example. The MULR instruction is the filter factor, which can be from 0.1 to 0.9. The example uses 0.2. A smaller filter factor increases filtering. You can use a higher precision value, but it is not generally needed. The filtered value is then converted back to binary and then to BCD. The filtered value is stored in location V1402 for use in your application or PID loop.

**NOTE:** Be careful not to do a multiple number conversion on a value. For example, if you are using the pointer method to get the analog value, it is in BCD and must be converted to binary. However, if you are using the conventional method of reading analog and are masking the first twelve bits, then it is already in binary and no conversion using the BIN instruction is needed.

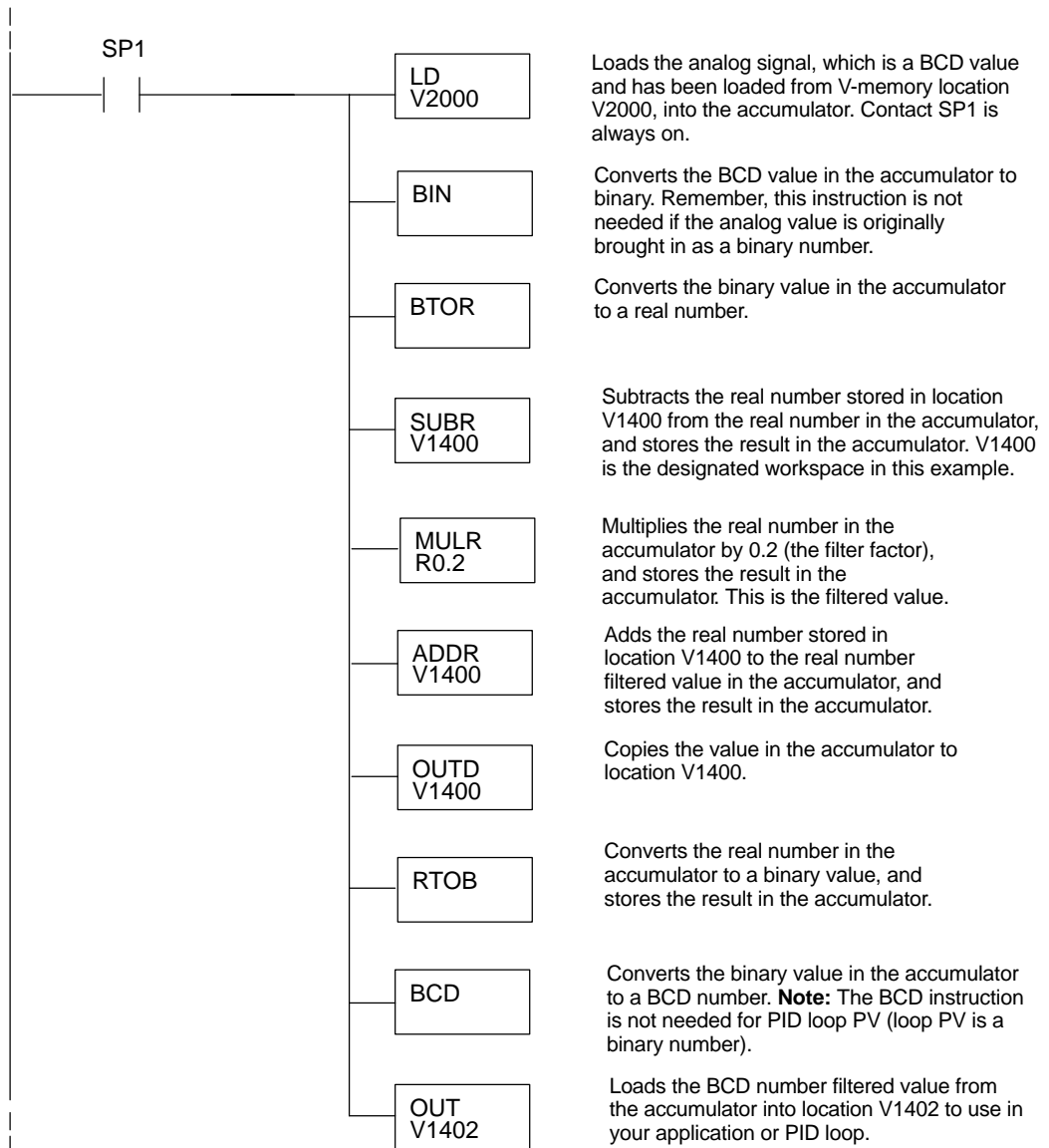

# **F2-04AD-2, F2-04AD-2L 4-Channel Analog Voltage Input**

---

In This Chapter. . . .

- Module Specifications
  - Setting the Module Jumpers
  - Connecting the Field Wiring
  - Module Operation
  - Writing the Control Program
-

## Module Specifications

The F2-04AD-2 (24 VDC input power model) and F2-04AD-2L (12 VDC input power model) Analog Input module provides several hardware features.

- Analog inputs are optically isolated from the PLC logic.
- The module has a removable terminal block so the module can be easily removed or changed without disconnecting the wiring.
- With a DL240/250-1/260 CPU, you can read all four channels in one scan.
- On-board active analog filtering and microcontroller provide digital signal processing to maintain precision analog measurements in noisy environments.
- F2-04AD-2: Low-power CMOS design requires less than 80mA from an external 18–26.4 VDC power supply.
- F2-04AD-2L: Low-power CMOS design requires less than 90mA from an external 10–15 VDC power supply.

**NOTE:** These two modules look very similar and it is very easy to mistake one module for the other. If your module does not work, check the terminal label to see if you have a 12 volts (L) or a 24 volts model and that it is being supplied with the proper input voltage.

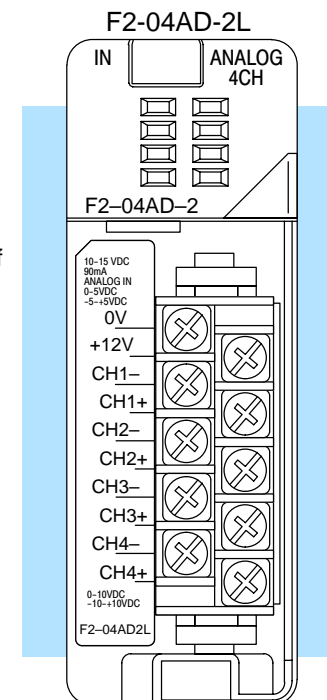
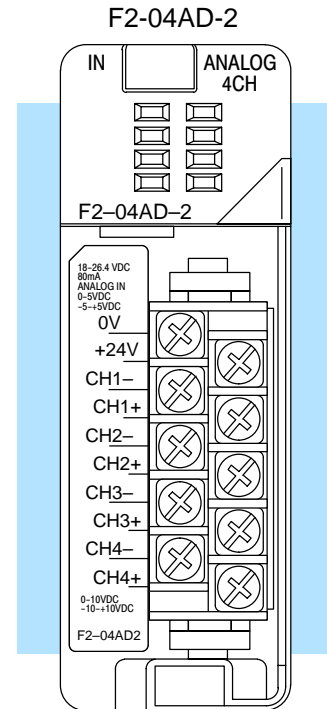

The following tables provide the specifications for the F2-04AD-2 and F2-04AD-2L Analog Input Modules (all specifications are the same for both modules except for the input voltage requirements). Review these specifications to make sure the module meets your application requirements.

### Input Specifications

Number of Channels	4, single ended (one common)
Input Ranges	0 to 5V, 0 to 10V, $\pm 5V$ , $\pm 10V$
Resolution	12 bit (1 in 4096) unipolar (0 – 4095) 13 bit (1 in 8192) bipolar ( $-4095$ – $+4095$ )
Common Mode Rejection	$-50$ dB at 800 Hz
Step Response	10 mS to 95% of full step change
Crosstalk	$-70$ dB, 1 count maximum
Active Low-pass Filtering	$-3$ dB at 50Hz, 2 poles ( $-12$ dB per octave)
Input Impedance	$> 20$ M $\Omega$
Absolute Maximum Ratings	$-75$ to $+75$ VDC
Converter type	Successive approximation
Linearity Error (End to End)	$\pm 1$ count (0.025% of span) maximum unipolar $\pm 2$ counts maximum bipolar
Input Stability	$\pm 1$ count
Full Scale Calibration Error (Offset error not included)	$\pm 3$ counts maximum
Offset Calibration Error	$\pm 1$ count maximum (0V input)
Maximum Inaccuracy	$\pm .1\%$ @ $25^{\circ}\text{C}$ ( $77^{\circ}\text{F}$ ) $\pm .3\%$ $0$ to $60^{\circ}\text{C}$ ( $32$ to $140^{\circ}\text{F}$ )
Accuracy vs. Temperature	$\pm 50$ ppm / $^{\circ}\text{C}$ full scale calibration change (including maximum offset change of 2 counts)

### General Specifications

PLC Update Rate	1 channel per scan maximum (D2-230 CPU) 4 channels per scan maximum (D2-240/250-1/260 CPU)
Digital Inputs	12 binary data bits, 2 channel ID bits, 1 sign/diagnostics bit, 1 diagnostic bit
Input points required	16 point (X) input module
Power Budget Requirement	60 mA maximum, 5 VDC (supplied by base)
External Power Supply	80 mA maximum, 18 to 26.4 VDC (F2-04AD-2) 90 mA maximum, 10 to 15 VDC (F2-04AD-2L)
Operating Temperature	$0$ to $60^{\circ}\text{C}$ ( $32$ to $140^{\circ}\text{F}$ )
Storage Temperature	$-20$ to $70^{\circ}\text{C}$ ( $-4$ to $158^{\circ}\text{F}$ )
Relative Humidity	5 to 95% (non-condensing)
Environmental air	No corrosive gases permitted
Vibration	MIL STD 810C 514.2
Shock	MIL STD 810C 516.2
Noise Immunity	NEMA ICS3-304

One count in the specification table is equal to one least significant bit of the analog data value (1 in 4096).

### Analog Input Configuration Requirements

The F2-04AD-2, (L) Analog Input appears as a 16-point discrete input module. The module can be installed in any slot of a DL205 system. The available power budget and discrete I/O points are the limiting factors. Check the user manual for your particular model of CPU and I/O base for more information regarding power budget and number of local, local expansion or remote I/O points.

**Special Placement Requirements (DL230 and Remote I/O Bases)**

Even though the module can be placed in any slot, it is important to examine the configuration if you are using a DL230 CPU. As you can see in the section on writing the program, you use V-memory locations to extract the analog data. If you place the module so that the input points do not start on a V-memory boundary, the instructions cannot access the data. This also applies when placing this module in a remote base using a D2-RSSS in the CPU slot.

**Correct!**

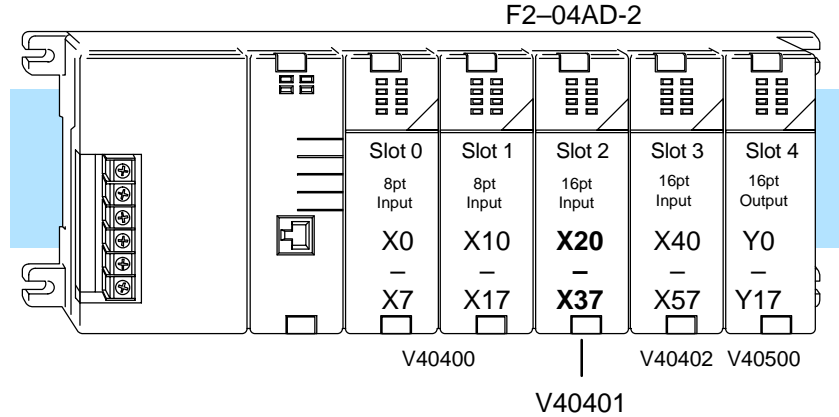

Data is correctly entered so input points start on a V-memory boundary.

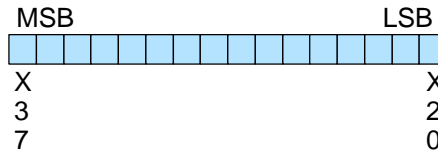

**Incorrect**

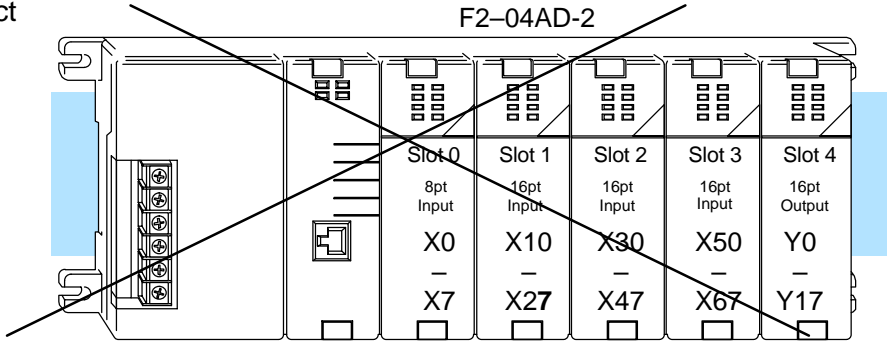

Data is split over two locations, so instructions cannot access data from a DL230.



To use the V-memory references required for a DL230 CPU, the *first* input address assigned to the module must be one of the following X locations. The table also shows the V-memory addresses that correspond to these X locations.

<b>X</b>	X0	X20	X40	X60	X100	X120	X140	X160
<b>V</b>	V40400	V40401	V40402	V40403	V40404	V40405	V40406	V40407

F2-04AD-2, (L)  
4-Ch. Voltage Input

## Setting the Module Jumpers

### Selecting the Number of Channels

There are two jumpers, labeled +1 and +2, that are used to select the number of channels that will be used. These jumpers are located on the motherboard, the one *with* the black D-shell style backplane connector. The module is set from the factory for four channel operation.

Any unused channels are not processed, so if you only select channels 1 thru 3, channel 4 will not be active. The following table shows how to use the jumpers to select the number of channels.

Channel	+1	+2
1	No	No
1, 2	Yes	No
1, 2, 3	No	Yes
1, 2, 3, 4	Yes	Yes

Yes = jumper installed

No = jumper removed

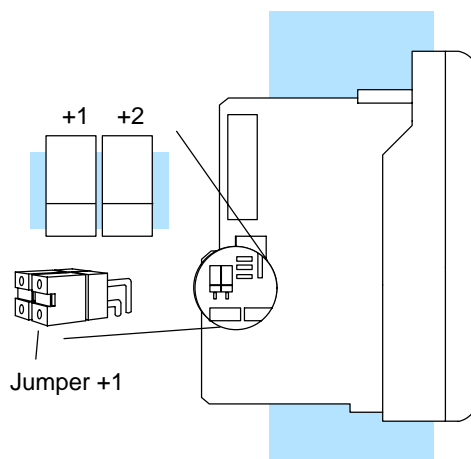

For example, to select all 4 channels (1–4), leave both jumpers installed. To select channel 1, remove both jumpers.

### Selecting the Input Signal Range

If you examine the smaller circuit board, which is on top of the motherboard, you will notice a jumper labeled “J2.” Use this jumper to select between the 5V ranges and the 10V ranges. The module comes from the factory set for 10V operation (jumper not installed).

Install jumper J2 for 0–5V or  $\pm 5V$  operation.

Remove J2, or store on a single pin, for 0 to 10 or  $\pm 10V$  operation.

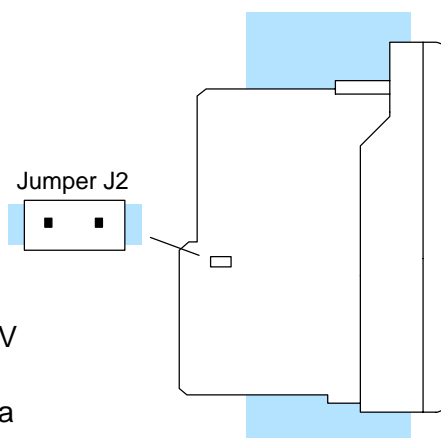

## Connecting the Field Wiring

### Wiring Guidelines

Your company may have guidelines for wiring and cable installation. If so, you should check those before you begin the installation. Here are some general things to consider:

- Use the shortest wiring route whenever possible.
- Use shielded wiring and ground the shield at the transmitter source. *Do not* ground the shield at both the module and the source.
- Do not run the signal wiring next to large motors, high current switches, or transformers. This may cause noise problems.
- Route the wiring through an approved cable housing to minimize the risk of accidental damage. Check local and national codes to choose the correct method for your application.

### User Power Supply Requirements

The module requires at least one field-side power supply. You may use the same or separate power sources for the module supply and the voltage transmitter supply. The F2-04AD-2 module requires 18–26.4VDC at 80 mA. The DL205 bases have built-in 24 VDC power supplies that provide up to 300mA of current. You may use this instead of a separate supply if you are using only a couple of analog modules.

It is desirable in some situations to power the transmitters separately in a location remote from the PLC. This will work as long as the transmitter supply meets the voltage and current requirements, and the transmitter minus (–) side and the module supply's minus (–) side are connected together.



**WARNING:** If you are using the 24 VDC base power supply, make sure you calculate the power budget. Exceeding the power budget can cause unpredictable system operation that can lead to a risk of personal injury or damage to equipment.

The DL205 base has a switching type power supply. As a result of switching noise, you may notice  $\pm 3$ –5 counts of instability in the analog input data if you use the base power supply. If this is unacceptable, you should try one of the following:

1. Use a separate linear power supply.
2. Connect the 24VDC common to the frame ground, which is the screw terminal marked “G” on the base.

By using these methods, the input stability is rated at  $\pm 1$  count.

The F2-04AD-2L requires 10–15VDC at 90mA and must be powered by a separate power supply.

**Custom Input Ranges**

Occasionally you may have the need to connect a (current) transmitter with an unusual signal range. By changing the wiring slightly and adding an external resistor to convert the current to voltage, you can easily adapt this module to meet the specifications for a transmitter that does not adhere to one of the standard input ranges. The following diagram shows how this works. The example below only shows channel 1, but you can also use the other channels as well.

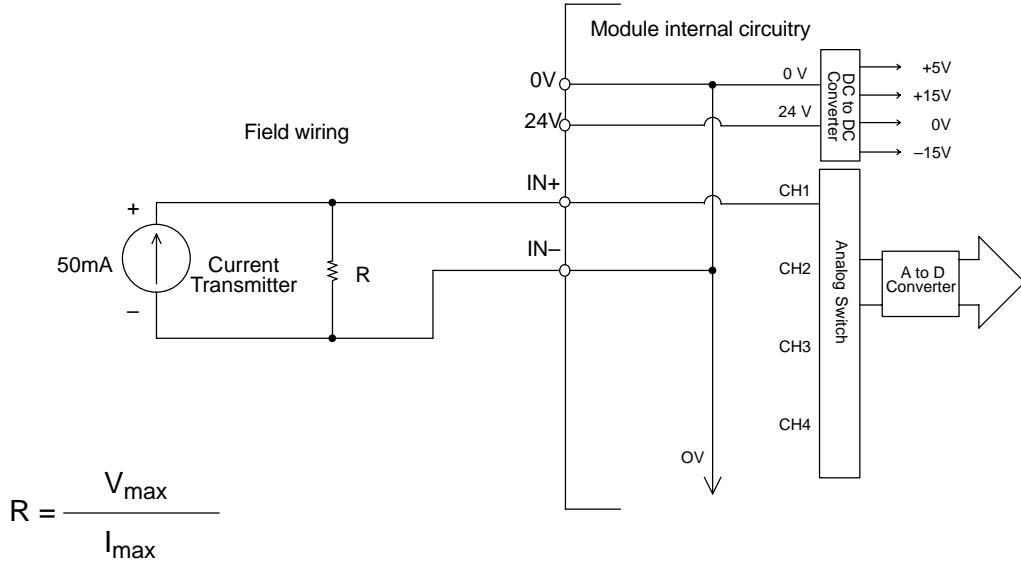

$$R = \frac{V_{\max}}{I_{\max}}$$

R = value of external resistor  
 $V_{\max}$  = high limit of selected voltage range (5V or 10V)  
 $I_{\max}$  = maximum current supplied by the transmitter

Example: current transmitter capable of 50mA, 0 – 10V range selected.

$$R = \frac{10V}{50mA} \quad R = 200 \text{ ohms}$$



**NOTE:** Your choice of resistor can affect the accuracy of the module. A resistor that has  $\pm 0.1\%$  tolerance and a  $\pm 50\text{ppm} / ^\circ\text{C}$  temperature coefficient is recommended.

If you use 4–20mA signals and convert them to voltage using this method, you can easily check for broken transmitter conditions. For example, if you are using the 0–5V range and the lowest signal for the 4–20mA transmitter is 4mA, the lowest digital value for the signal is not 0, but instead is 819.

If the transmitter is working properly, the smallest value would be 819 in the DL205. If you see a value of less than about 750 (allowing for tolerance), then you know the transmitter is broken.

**Wiring Diagram**

The module has a removable connector to make wiring easier. Simply squeeze the top and bottom retaining clips and gently pull the connector from the module. Use the following diagram to connect the field wiring. The diagram shows separate module and transmitter power supplies. If you desire to use only one field-side supply, just combine the supplies' positive (+) terminals into one node and remove the transmitter supply.

- Notes: 1. Shields should be grounded at the signal source.  
 2. Unused inputs should be jumpered together (i.e. Ch4- to Ch4+).  
 3. More than one external power supply can be used provided the commons are connected together.  
 4. F2-04AD-2L requires 10-15 VDC input supply.

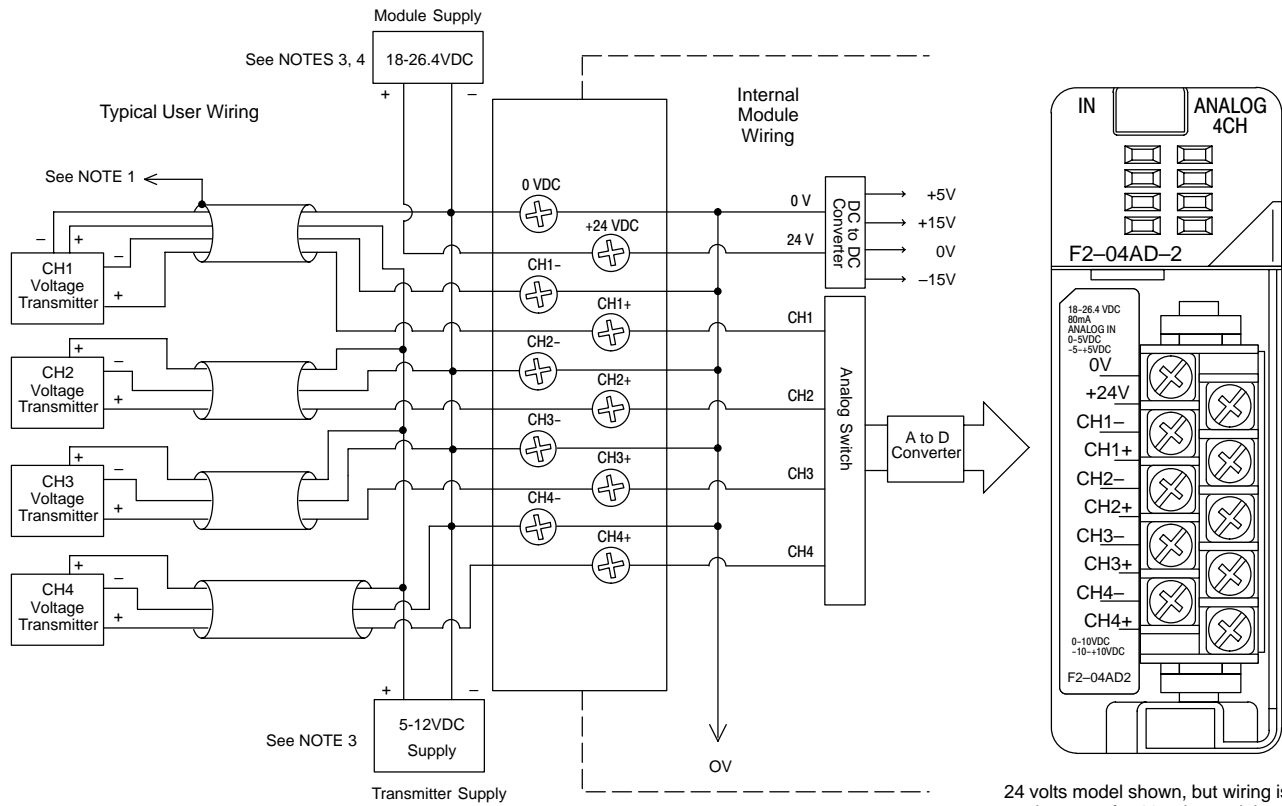

24 volts model shown, but wiring is the same for 12 volts model.

F2-04AD-2, (L)  
4-Ch. Voltage Input

## Module Operation

### Channel Scanning Sequence for a DL230 CPU (Multiplexing)

Before you begin writing the control program, it is important to take a few minutes to understand how the module processes and represents the analog signals.

The module can supply different amounts of data per scan, depending on the type of CPU you are using. The DL230 can obtain one channel of data per CPU scan. Since there are four channels, it can take up to four scans to get data for all channels. Once all channels have been scanned the process starts over with channel 1. Unused channels are not processed, so if you select only two channels, then each channel will be updated every other scan. The multiplexing method can also be used for the DL240/250-1/DL260 CPUs.

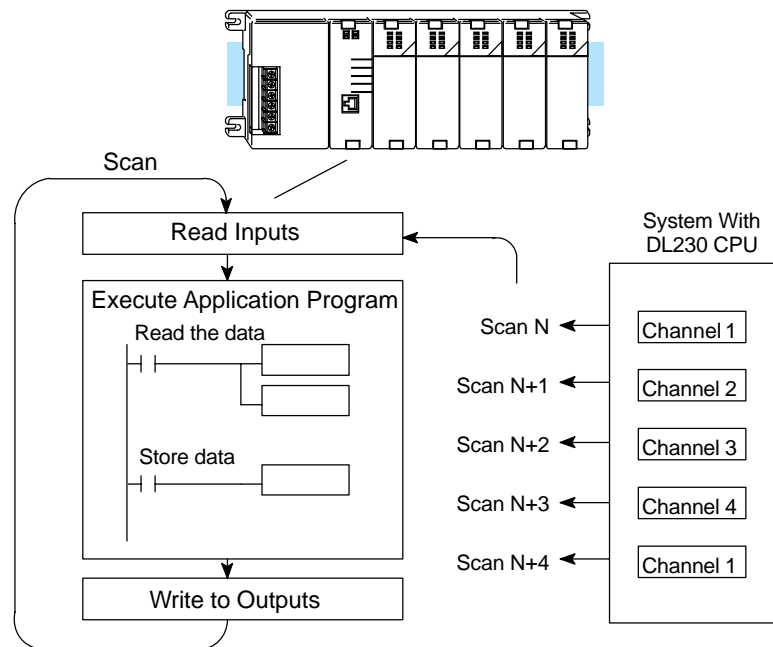

### Channel Scanning Sequence with a DL240, DL250-1 or DL260 CPU (Pointer Method)

If you are using a DL240, DL250-1 or DL260 CPU, you can obtain all four channels of input data in one scan. This is because the DL240/250-1/260 CPU supports special V-memory locations that are used to manage the data transfer (this is discussed in more detail in the section on Writing the Control Program).

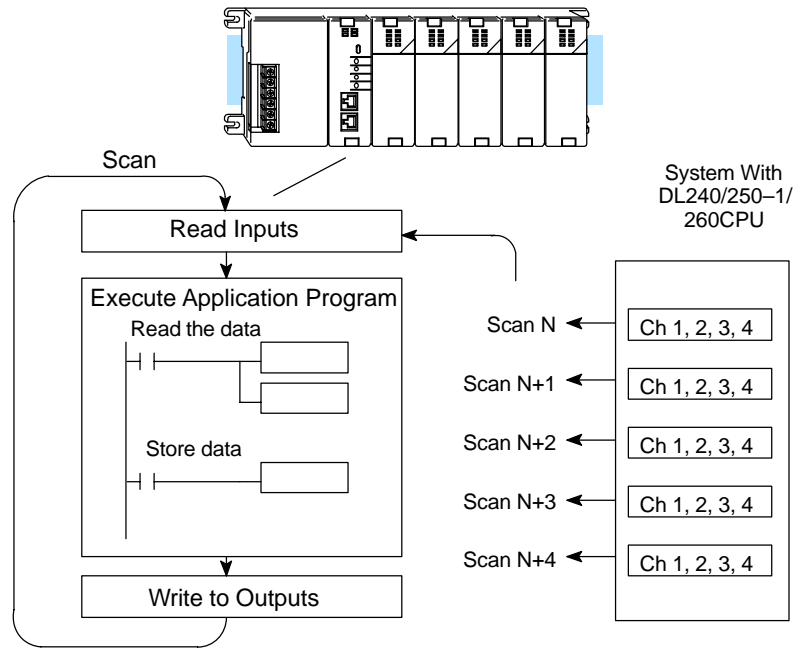

### Analog Module Updates

Even though the channel updates to the CPU are synchronous with the CPU scan, the module asynchronously monitors the analog transmitter signal and converts the signal to a 12-bit binary representation. This enables the module to continuously provide accurate measurements without slowing down the discrete control logic in the RLL program.

For the vast majority of applications, the values are updated much faster than the signal changes. However, in some applications, the update time can be important. The module takes approximately 10 milliseconds to sense 95% of the change in the analog signal.

Note, this is *not* the amount of time required to convert the signal to a digital representation. The conversion to the digital representation takes only a few microseconds. Many manufacturers list the conversion time, but it is the settling time of the filter that really determines the update time.

F2-04AD-2, (L)  
4-Ch. Voltage Input

**Understanding the Input Assignments**

You may recall that the module appears to the CPU as a 16-point discrete input module. You can use these points to obtain:

- an indication of which channel is active.
- the digital representation of the analog signal.
- module diagnostic information.

Since all input points are automatically mapped into V memory, it is very easy to determine the location of the data word that will be assigned to the module.

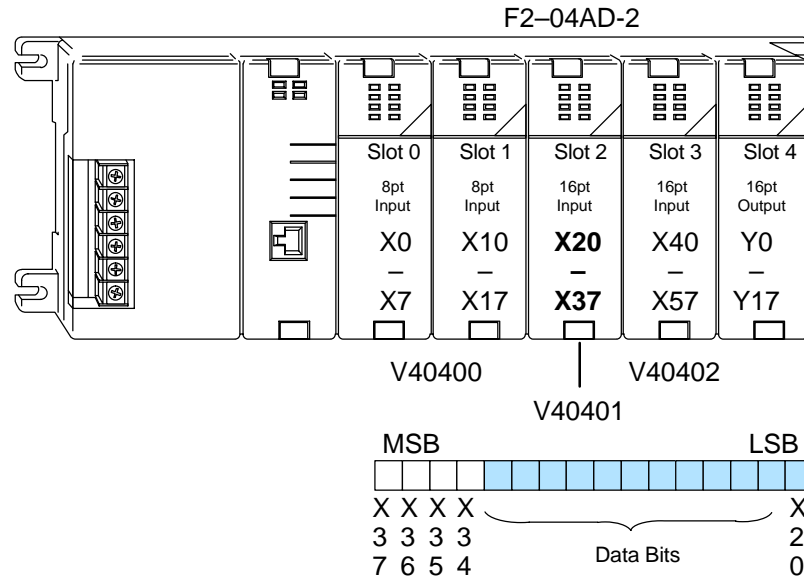

Within these word locations, the individual bits represent specific information about the analog signal.

**Analog Data Bits**

The first twelve bits represent the analog data in binary format.

Bit	Value	Bit	Value
0	1	6	64
1	2	7	128
2	4	8	256
3	8	9	512
4	16	10	1024
5	32	11	2048

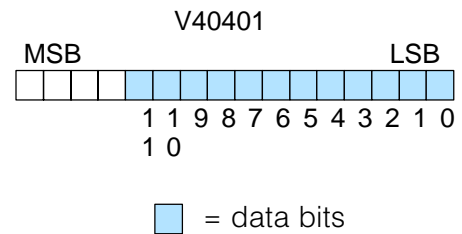

**Active Channel Indicator Inputs**

Two of the inputs are binary encoded to indicate the active channel (remember, the V-memory bits are mapped directly to discrete inputs). The inputs automatically turn on and off to indicate the current channel for each scan.

Scan	X35	X34	Channel
N	Off	Off	1
N+1	Off	On	2
N+2	On	Off	3
N+3	On	On	4
N+4	Off	Off	1

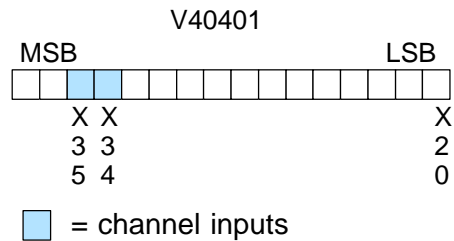

F2-04AD-2, (L)  
4-Ch. Voltage Input

### Module Diagnostic and Sign Inputs

The last two inputs are used for module diagnostics.

**Module Busy** — The first diagnostic input (X36 in this example) indicates a “busy” condition. This input will always be active on the first PLC scan, to tell the CPU that the analog data is not valid. After the first scan, the input usually only comes on when extreme environmental (electrical) noise problems are present.

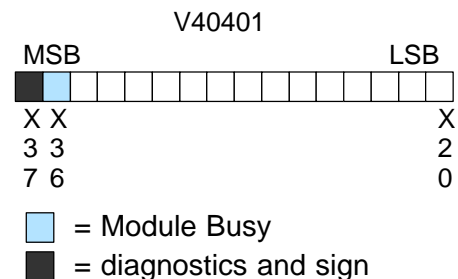

The last input (X37 in this example) is used for two purposes.

**Signal Sign** — When using bipolar ranges you need to know if the value returned is positive or negative. When this input is off, the value stored represents a positive analog signal (0V or greater). If the input is on, then the value stored represents a negative input signal (less than 0V).

**Channel Failure** — This input can also indicate an analog channel failure. For example, if the 24 VDC input power is missing or the terminal block is loose, the module turns on this input and returns a data value of zero (remember, if this input is on and the data value is *not* equal to zero, then it is just showing the sign).

The next section, Writing the Control Program, shows how you can use these inputs in your control program.

### Module Resolution

Since the module has 12-bit unipolar resolution, the analog signal is converted into 4096 counts ranging from 0 – 4095 ( $2^{12}$ ). For example, with a 0 to 10V scale, a 0V signal would be 0 and a 10V signal would be 4095. This is equivalent to a binary value of 0000 0000 0000 to 1111 1111 1111, or 000 to FFF hexadecimal. The diagram shows how this relates to each signal range.

The bipolar ranges utilize a sign bit to provide 13-bit resolution. A value of 4095 can represent the upper limit of either side of the range. Use the sign bit to determine negative values.

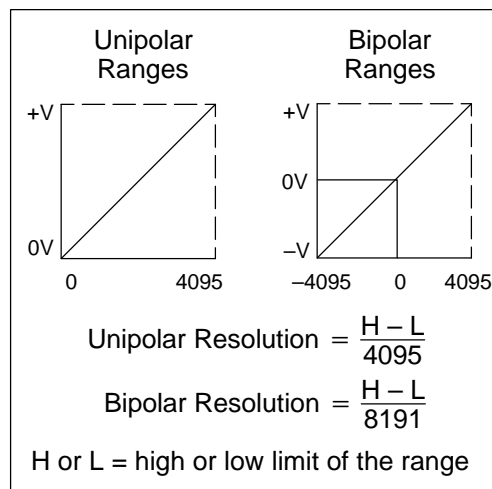

Each count can also be expressed in terms of the signal level by using the equation shown. The following table shows the smallest detectable signal change that will result in one LSB change in the data value for each input signal range.

Range	Signal Span (H – L)	Divide By	Smallest Detectable Change
0 to +10V	10V	4095	2.44 mV
-10 to +10V	20V	8191	2.44 mV
0 to +5V	5V	4095	1.22 mV
-5V to +5V	10V	8191	1.22 mV

# Writing the Control Program

## Reading Values: Pointer Method and Multiplexing

There are two methods of reading values:

- The pointer method
- Multiplexing

You *must* use the multiplexing method when using a DL230 CPU. You must also use the multiplexing method with remote I/O modules (the pointer method will not work). You can use either method when using DL240, DL250-1 and DL260 CPUs, but for ease of programming it is strongly recommended that you use the pointer method.

DL240, DL250-1 and DL260 CPUs have special V-memory locations assigned to each base slot that greatly simplify the programming requirements. These V-memory locations:

- specify the data format
- specify the number of channels to scan
- specify the storage locations

### Pointer Method

X	✓	✓	✓
230	240	250-1	260



**NOTE:** DL250 CPUs with firmware release version 1.06 or later support this method. If you must use the DL230 example, module placement in the base is very important. Review the section earlier in this chapter for guidelines.

The example program shows how to setup these locations. Place this rung anywhere in the ladder program or in the Initial Stage if you are using RLL<sup>PLUS</sup> instructions. This is all that is required to read the data into V-memory locations. Once the data is in V-memory, you can perform math on the data, compare the data against preset values, and so forth. V2000 is used in the example but you can use any user V-memory location. In this example the module is installed in slot 2. You should use the V-memory locations for your module placement. The pointer method automatically converts values to BCD.

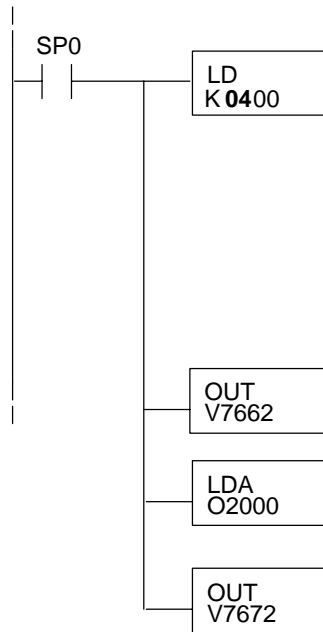

- or - LD K8400

Loads a constant that specifies the number of channels to scan and the data format. The upper byte, most significant nibble (MSN) selects the data format (i.e. 0=BCD, 8=Binary), the LSN selects the number of channels (i.e. 1, 2, 3, or 4).

The binary format is used for displaying data on some operator interfaces. The DL230/240 CPUs do not support binary math functions, whereas the DL250 does.

Special V-memory location assigned to slot 2 that contains the number of channels to scan.

This loads an octal value for the first V-memory location that will be used to store the incoming data. For example, the O2000 entered here would designate the following addresses.  
Ch1 – V2000, Ch2 – V2001, Ch3 – V2002, Ch 4 – V2003

The octal address (O2000) is stored here. V7672 is assigned to slot 2 and acts as a pointer, which means the CPU will use the octal value in this location to determine exactly where to store the incoming data.

The tables below show the special V-memory locations used by the DL240, DL250–1 and DL260 for the CPU base and local expansion base I/O slots. Slot 0 (zero) is the module next to the CPU or D2–CM module. Slot 1 is the module two places from the CPU or D2–CM, and so on. Remember, the CPU only examines the pointer values at these locations after a mode transition. Also, if you use the DL230 (multiplexing) method, verify that these addresses in the CPU are zero.

The Table below applies to the DL240, DL250–1 and DL260 CPU base.

<b>CPU Base: Analog Input Module Slot-Dependent V-memory Locations</b>								
Slot	0	1	2	3	4	5	6	7
No. of Channels	V7660	V7661	V7662	V7663	V7664	V7665	V7666	V7667
Storage Pointer	V7670	V7671	V7672	V7673	V7674	V7675	V7676	V7677

The Table below applies to the DL250–1 or DL260 expansion base 1.

<b>Expansion Base D2–CM #1: Analog Input Module Slot-Dependent V-memory Locations</b>								
Slot	0	1	2	3	4	5	6	7
No. of Channels	V36000	V36001	V36002	V36003	V36004	V36005	V36006	V36007
Storage Pointer	V36010	V36011	V36012	V36013	V36014	V36015	V36016	V36017

The Table below applies to the DL250–1 or DL260 expansion base 2.

<b>Expansion Base D2–CM #2: Analog Input Module Slot-Dependent V-memory Locations</b>								
Slot	0	1	2	3	4	5	6	7
No. of Channels	V36100	V36101	V36102	V36103	V36104	V36105	V36106	V36107
Storage Pointer	V36110	V36111	V36112	V36113	V36114	V36115	V36116	V36117

The Table below applies to the DL260 CPU expansion base 3.

<b>Expansion Base D2–CM #3: Analog Input Module Slot-Dependent V-memory Locations</b>								
Slot	0	1	2	3	4	5	6	7
No. of Channels	V36200	V36201	V36202	V36203	V36204	V36205	V36206	V36207
Storage Pointer	V36210	V36211	V36212	V36213	V36214	V36215	V36216	V36217

The Table below applies to the DL260 CPU expansion base 4.

<b>Expansion Base D2–CM #4: Analog Input Module Slot-Dependent V-memory Locations</b>								
Slot	0	1	2	3	4	5	6	7
No. of Channels	V36300	V36301	V36302	V36303	V36304	V36305	V36306	V36307
Storage Pointer	V36310	V36311	V36312	V36313	V36314	V36315	V36316	V36317

**Using Bipolar Ranges (Pointer Method)**

X	✓	✓	✓
230	240	250-1	260

With bipolar ranges, you need some additional logic to determine whether the value being returned represents a positive voltage or a negative voltage. For example, you may need to know the direction for a motor. With the DL240/250 CPU, you *cannot* use the last input (X37 in the previous examples) to show the sign for each channel. This is because the DL240/250-1/260 reads all four channels in one scan. Therefore, if you tried to use X37 you would only be monitoring the last channel that was read. You would not be able to determine the sign for the previous three channels. There is a simple solution:

- If you get a value greater than or equal to 8001, the value is negative.

The sign bit is the most significant bit, which combines 8000 to the data value. If the value is greater than or equal to 8001, you only have to mask the most significant bit and the active channel bits to determine the actual data value.

The following program shows how you can accomplish this. Since you always want to know when a value is negative, these rungs should be placed *before* any other operations that use the data, such as math instructions, scaling operations, and so forth. Also, if you are using stage programming instructions, these rungs should be in a stage that is always active. Please note, you only need this logic for each channel that is using bipolar input signals. The example only shows two channels.

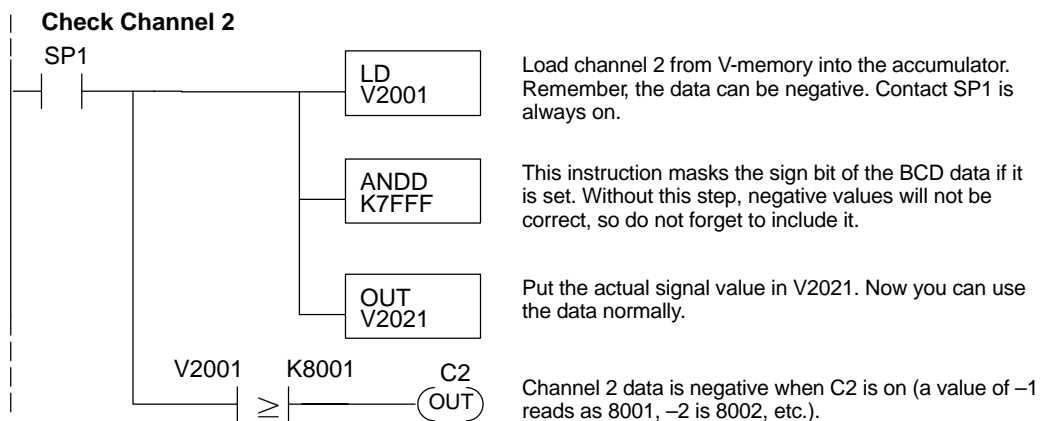
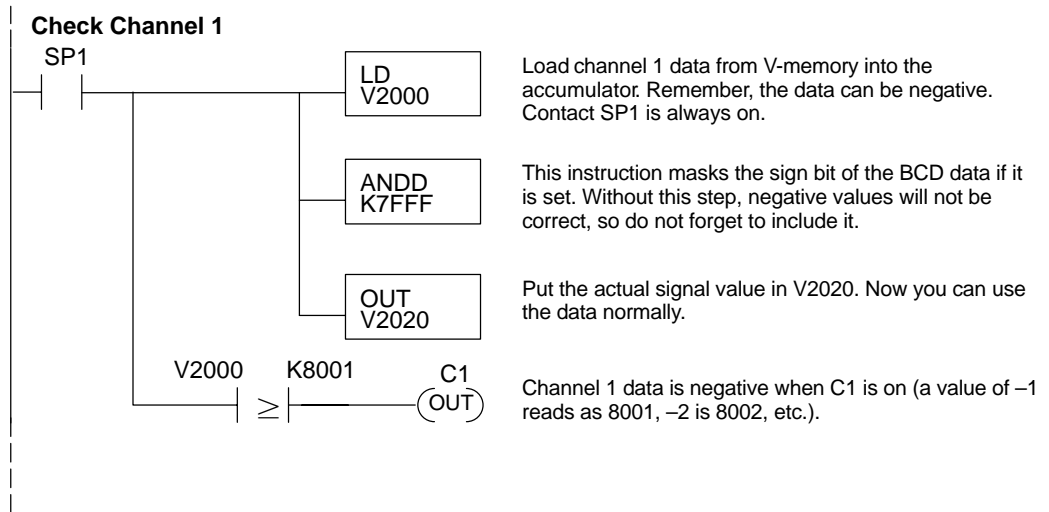

### Reading Values (Multiplexing)

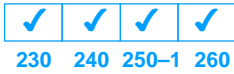

The DL230 CPU *does not* have the special V-memory locations that allow you to automatically enable the data transfer. Since all channels are multiplexed from a single data word, the control program must be setup to determine which channel is being read. Since the module appears as 16 X input points to the CPU, it is very easy to use the active channel status bits to determine which channel is being monitored.

Note, this example is for a module installed as shown in the previous examples. The addresses used would be different if the module was used in a different I/O configuration. You can place these rungs anywhere in the program, or if you are using stage programming place them in a stage that is always active.

#### Load data when module is not busy.

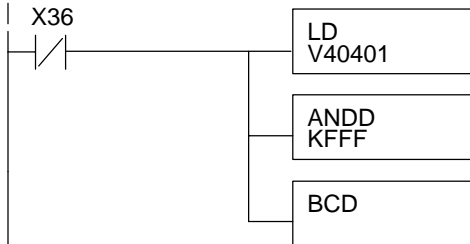

Loads the complete data word into the accumulator. The V-memory location depends on the I/O configuration. See Appendix A for the memory map.

This instruction masks the channel identification bits. Without this, the values used will not be correct, so do not forget to include it.

It is usually easier to perform math operations in BCD. So it is best to convert the data to BCD immediately. You can leave out this instruction if your application does not require it.

#### Store Channel 1

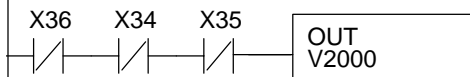

When the module is not busy and X34 and X35 are off, channel 1 data is stored in V2000.

#### Store Channel 2

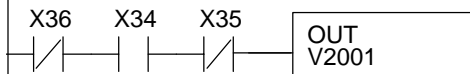

When X34 is on and X35 is off, channel 2 data is stored in V2001.

#### Store Channel 3

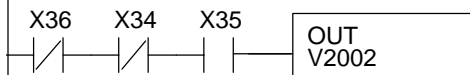

When X34 is off and X35 is on, channel 3 data is stored in V2002.

#### Store Channel 4

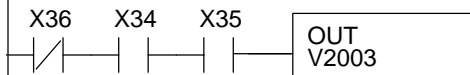

When both X34 and X35 are on, channel 4 data is stored in V2003.

F2-04AD-2, (L)  
4-Ch. Voltage Input

**Single Channel Selected**

Since you do not have to determine which channel is selected, the single channel program is even simpler.

**Store channel 1 when module is not busy.**

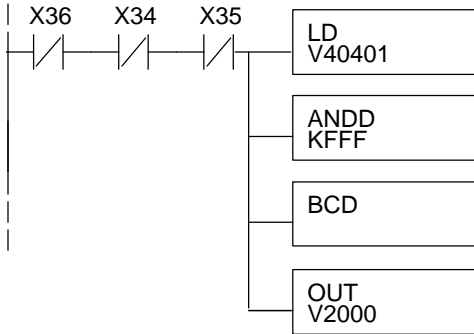

Loads the complete data word into the accumulator. The V-memory location depends on the I/O configuration. See Appendix A for the memory map.

This instruction masks the channel identification bits. Without this, the values used will not be correct, so do not forget to include it.

It is usually easier to perform math operations in BCD, so it is best to convert the data to BCD immediately. You can leave out this instruction if your application does not require it.

When the module is not busy and X34 and X35 are off, channel 1 data is stored in V2000.

**Using Bipolar Ranges (Multiplexing)**

With bipolar ranges, you need some additional logic because you need to know if the value being returned represents a positive voltage or a negative voltage. For example, you may need to know the direction for a motor. Since the DL230 only reads one channel per scan, you can use the last input (X37 in the examples) to show the sign.

The following program shows how you can accomplish this. Since you always want to know when a value is negative, these rungs should be placed *before* any operations that use the data, such as math instructions, scaling operations, and so forth. Also, if you are using stage programming instructions these rungs should be in a stage that is always active. Please note, you only need the additional logic for those channels that are using bipolar input signals. The example shows two channels but you can repeat these steps for all four channels if necessary.

**Load data when module is not busy.**

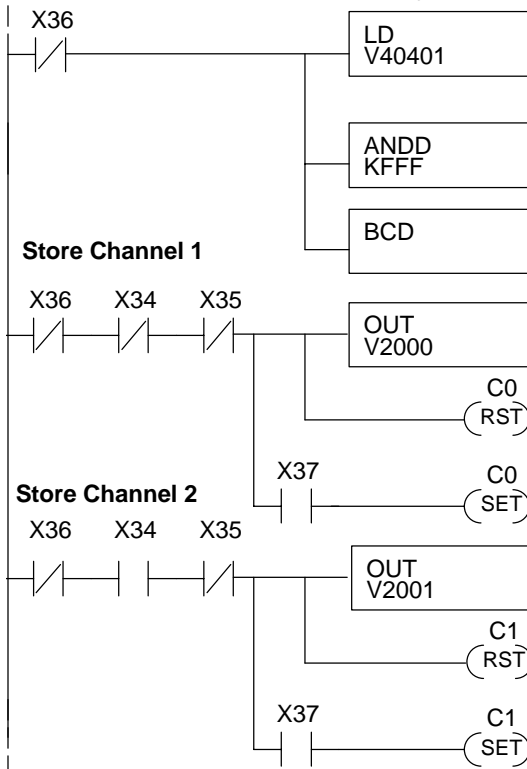

Loads the complete data word into the accumulator. The V-memory location depends on the I/O configuration. See Appendix A for the memory map.

This instruction masks the channel identification bits. Without this, the values used will not be correct, so do not forget to include it.

It is usually easier to perform math operations in BCD, so it is best to convert the data to BCD immediately. You can leave out this instruction if your application does not require it.

When the module is not busy and X34 and X35 are off, channel 1 data is stored in V2000. C0 is reset to indicate channel one's value is positive.

If X37 is on, then the data value represents a negative voltage. C0 is set to indicate channel 1's value is negative.

When the module is not busy, and X34 is on and X35 is off, channel 2 data is stored in V2001. C1 is reset to indicate that channel 2's value is positive.

If X37 is on, then the data value represents a negative voltage. C1 is set to indicate that channel 2's value is negative.

**Using 2's Complement (Multiplexing)**

✓ 230 ✓ 240 ✓ 250-1 ✓ 260

The 2's complement data format may be required to display negative values on some operator interface devices. It could also be used to simplify data averaging on bipolar signals.

The example shows two channels, but you can repeat these steps for all four channels if necessary.

**Load data when module is not busy.**

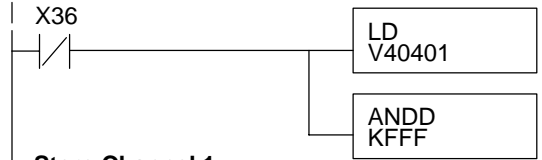

Loads the complete data word into the accumulator. The V-memory location depends on the I/O configuration. See Appendix A for the memory map.

This instruction masks the channel identification bits. Without this, the values used will not be correct, so do not forget to include it.

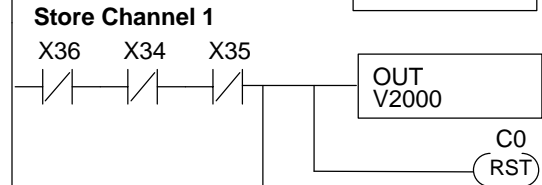

When the module is not busy and X34 and X35 are off, channel 1 data is stored in V2000. C0 is reset to indicate that channel 1's value is positive.

If X37 is on, then the data value represents a negative voltage. C0 is set to indicate that channel 1's value is negative.

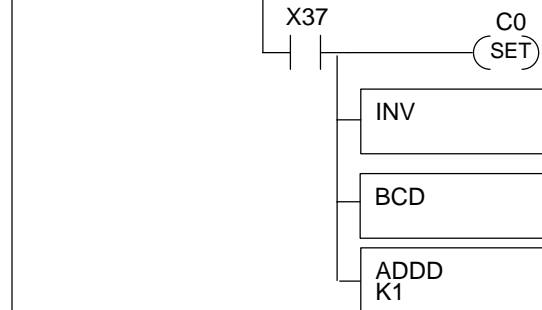

Invert the bit pattern in the accumulator.

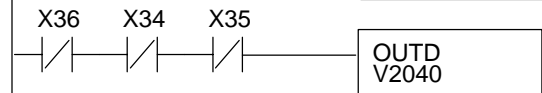

Channel 1 data is in double word starting at V2040.

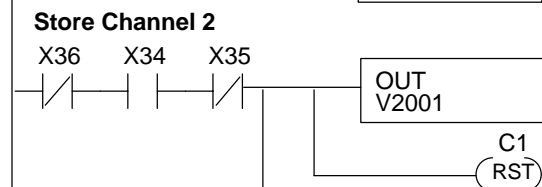

When the module is not busy and X34 is on and X35 is off, channel 2 data is stored in V2001. C1 is reset to indicate channel 2's value is positive.

If X37 is on, then the data value represents a negative voltage. C1 is set to indicate that channel 2's value is negative.

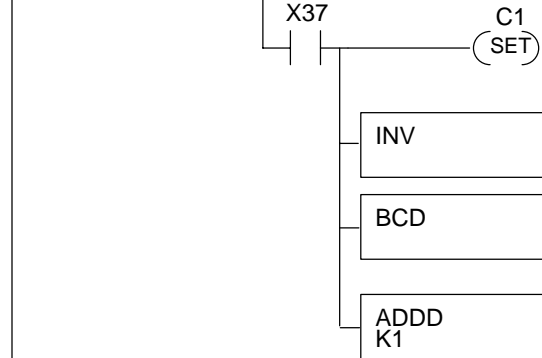

Invert the bit pattern in the accumulator.

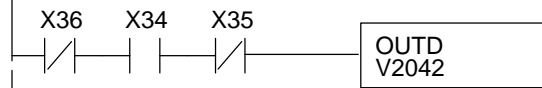

Channel 2 data is in double word starting at V2042.

F2-04AD-2, (L)  
4-Ch. Voltage Input

**Analog Power Failure Detection**

The analog module has a microcontroller that can diagnose analog input circuit problems. You can easily create a simple ladder rung to detect these problems. This rung shows an input point that would be assigned if the module was used as shown in the previous examples. A different point would be used if the module was installed in a different I/O configuration.

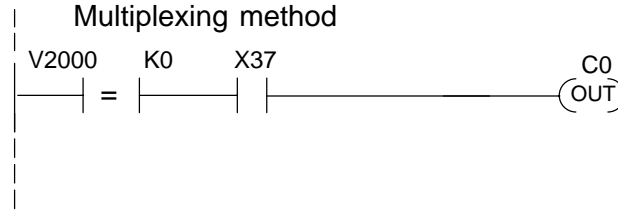

V-memory location V2000 holds channel 1 data. When a data value of zero is returned and input X37 is on, then the analog circuitry is not operating properly.

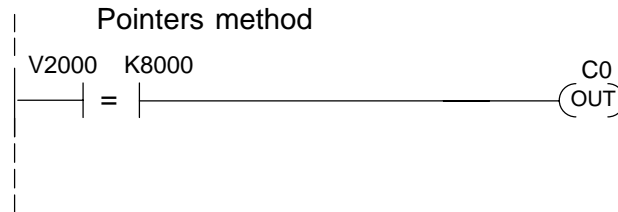

V-memory location V2000 holds channel 1 data. When a data value of 8000 is returned, then the analog circuitry is not operating properly.

**Scaling the Input Data**

Most applications usually require measurements in engineering units, which provide more meaningful data. This is accomplished by using the conversion formula shown.

You may have to make adjustments to the formula depending on the scale you choose for the engineering units.

$$\text{Units} = A \frac{H - L}{4095}$$

H = high limit of the engineering unit range

L = low limit of the engineering unit range

A = Analog value (0 – 4095)

For example, if you wanted to measure pressure (PSI) from 0.0 to 99.9 then you would have to multiply the analog value by 10 in order to imply a decimal place when you view the value with the programming software or a handheld programmer. Notice how the calculations differ when you use the multiplier.

Analog Value of 2024, slightly less than half scale, should yield 49.4 PSI

Example without multiplier

$$\text{Units} = A \frac{H - L}{4095}$$

$$\text{Units} = 2024 \frac{100 - 0}{4095}$$

$$\text{Units} = 49$$

Handheld Display

V 2001	V 2000
0000	0049

Example with multiplier

$$\text{Units} = 10 A \frac{H - L}{4095}$$

$$\text{Units} = 20240 \frac{100 - 0}{4095}$$

$$\text{Units} = 494$$

Handheld Display

V 2001	V 2000
0000	0494

This value is more accurate.

Here is how you would write the program to perform the engineering unit conversion. This example assumes you have BCD data loaded into the appropriate V-memory locations using instructions that apply for the model of CPU you are using.



**NOTE:** This example uses SP1, which is always on. You could also use an X, C, etc. permissive contact.

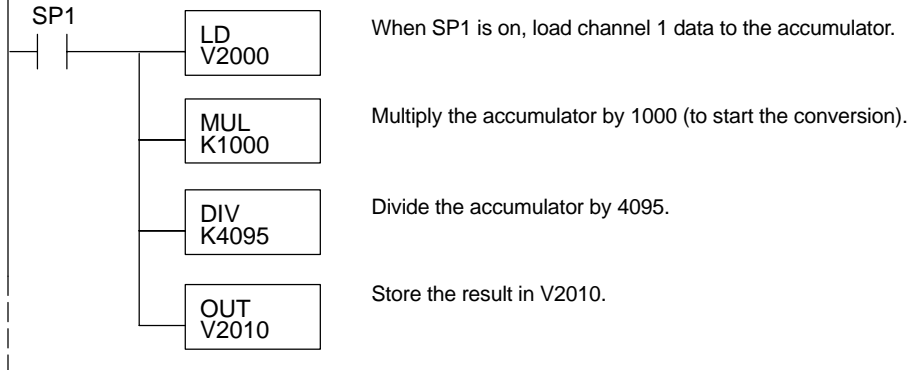

**Analog and Digital Value Conversions**

Sometimes it is useful to be able to quickly convert between the signal levels and the digital values. This is especially helpful during machine startup or troubleshooting. Remember, this module *does not* operate like other versions of analog input modules that you may be familiar with. The bipolar ranges use 0–4095 for both positive and negative voltages. The sign bit allows this, which actually provides better resolution than those modules that do not offer a sign bit. The following table provides formulas to make this conversion easier.

Range	If you know the digital value ...	If you know the signal level ...
0 to 5V -5V to +5V	$A = \frac{5D}{4095}$	$D = \frac{4095}{5} (A)$
0 to 10V -10V to +10V	$A = \frac{-10D}{4095}$	$D = \frac{4095}{10} \text{ABS}(A)$

For example, if you are using the -10 to +10V range and you have measured the signal at 6V, use the following formula to determine the digital value that is stored in the V-memory location that contains the data.

$$D = \frac{4095}{10} (A)$$

$$D = \frac{4095}{10} (6V)$$

$$D = (409.5) (6)$$

$$D = 2457$$

**Filtering Input Noise (DL250-1, DL260 CPUs Only)**

X	X	✓	✓
230	240	250-1	260



Add the following logic to filter and smooth analog input noise in DL250-1/DL260 CPUs. This is especially useful when using PID loops. Noise can be generated by the field device and/or induced by field wiring.

The analog value in BCD is first converted to a binary number because there is not a BCD-to-real conversion instruction. Memory location V1400 is the designated workspace in this example. The MULR instruction is the filter factor, which can be from 0.1 to 0.9. The example uses 0.2. A smaller filter factor increases filtering. You can use a higher precision value, but it is not generally needed. The filtered value is then converted back to binary and then to BCD. The filtered value is stored in location V1402 for use in your application or PID loop.

**NOTE:** Be careful not to do a multiple number conversion on a value. For example, if you are using the pointer method to get the analog value, it is in BCD and must be converted to binary. However, if you are using the conventional method of reading analog and are masking the first twelve bits, then it is already in binary and no conversion using the BIN instruction is needed.

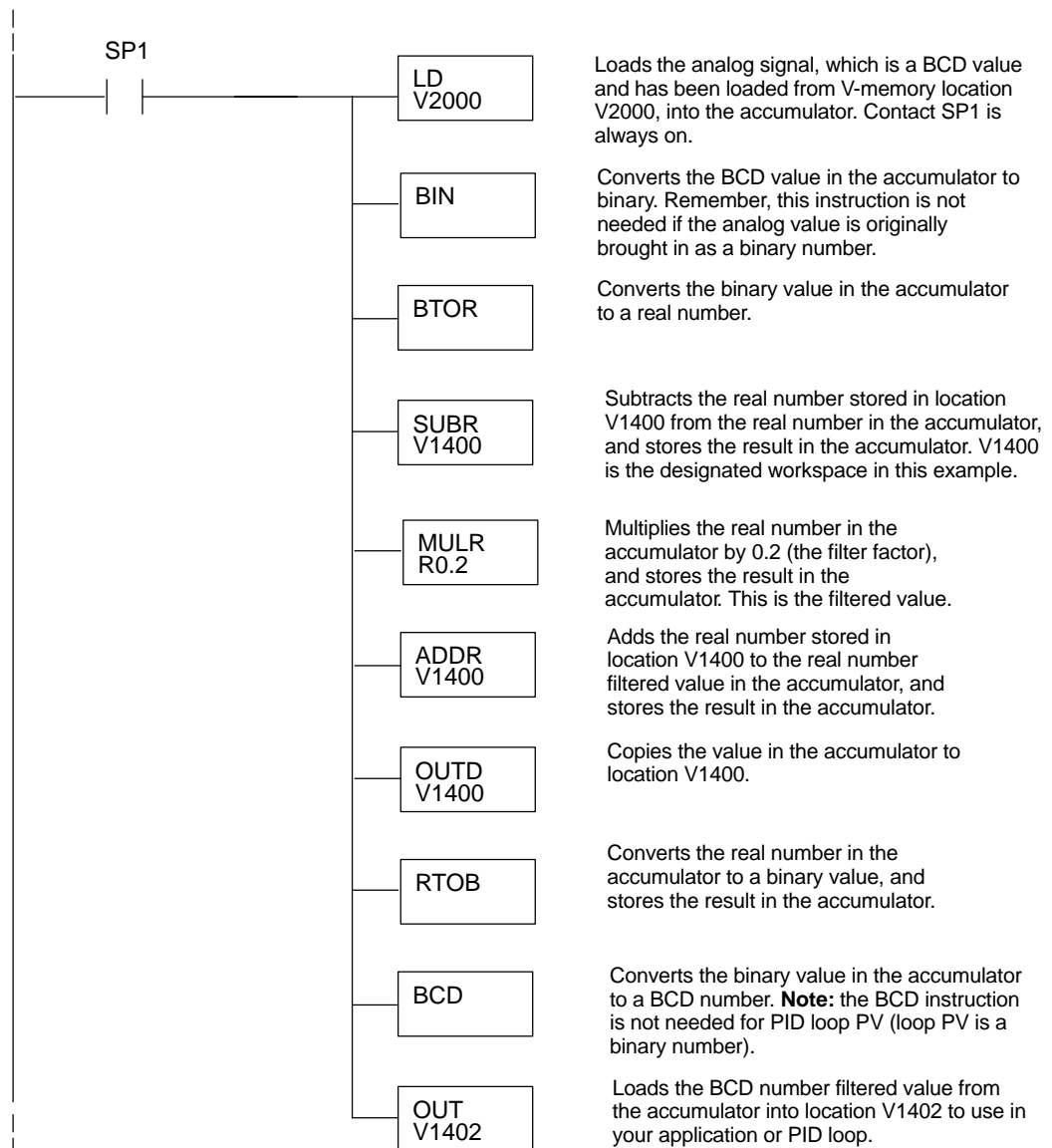

# F2-08AD-1

## 8-Channel Analog Current Input

---

In This Chapter. . . .

- Module Specifications
  - Setting the Module Jumpers
  - Connecting the Field Wiring
  - Module Operation
  - Writing the Control Program
-

## Module Specifications

The F2-08AD-1 Analog Input module provides several hardware features:

- Analog inputs are optically isolated from the PLC logic.
- On-board 250 ohm, 1/2 watt precision resistors provide substantial over-current-protection for 4–20mA current loops.
- The module has a removable terminal block so the module can be easily removed or changed without disconnecting the wiring.
- With a DL240, DL250–1 and DL260 CPU, you can read all channels in one scan.
- Low-power CMOS design requires less than 80mA from an external 18–26.4 VDC power supply.

### Firmware Requirements:

To use this module, D2–230 CPUs must have firmware version 1.6 or later. To use the pointer method of writing values, D2–240 CPUs require firmware version 2.2 or later and D2–250 CPUs require firmware version 1.06 or later.

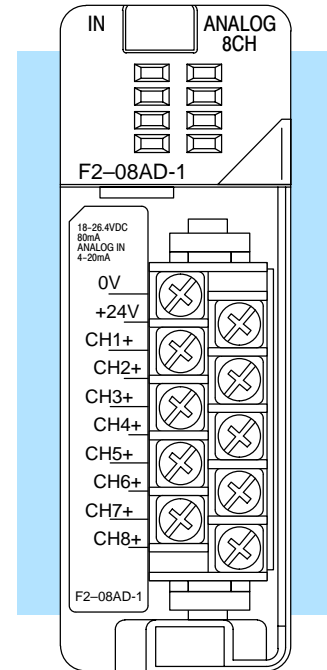

The following tables provide the specifications for the F2-08AD-1 Analog Input Module. Review these specifications to make sure the module meets your application requirements.

### Input Specifications

Number of Channels	8, single ended (one common)
Input Range	4 to 20 mA current
Resolution	12 bit (1 in 4096)
Step Response	7 mS to 95% of full step change
Crosstalk	-70 dB, 1 count maximum
Input Filtering	$f_{-3dB}$ @ 200Hz, -6 dB / octave
Input Impedance	250 $\Omega$ $\pm$ 0.1%, 1/2W current input
Absolute Maximum Ratings	-45 mA to +45 mA, current input
Linearity Error (End to End)	$\pm$ 1 count (0.025% of full scale) maximum
Input Stability	$\pm$ 1 count
Full Scale Calibration Error (Offset Error Included)	$\pm$ 5 counts maximum, @ 20.000mA
Offset Calibration Error	$\pm$ 2 counts maximum, @ 4.000mA
Maximum Inaccuracy	$\pm$ .1% @ 25°C $\pm$ .25% 0 to 60°C (32 to 140°F)
Accuracy vs. Temperature	$\pm$ 50 ppm/°C maximum full scale calibration (including maximum offset change)
Recommended Fuse (external)	0.032 A, Series 217 fast-acting, current inputs

### General Specifications

PLC Update Rate	1 channel per scan maximum (DL230 CPU) 8 channels per scan maximum (DL240/250-1/260 CPU)
Data Acquisition Time	3ms/channel (asynchronous)
Digital Inputs Input Points Required	12 binary data bits, 3 channel ID bits, 1 broken transmitter detection bit 16 point (X) input module
Power Budget Requirement	50 mA maximum, 5 VDC (supplied by base)
External Power Supply	80 mA maximum, 18 to 26.4 VDC
Operating Temperature	0 to 60° C (32 to 140° F)
Storage Temperature	-20 to 70° C (-4 to 158° F)
Relative Humidity	5 to 95% (non-condensing)
Environmental air	No corrosive gases permitted
Vibration	MIL STD 810C 514.2
Shock	MIL STD 810C 516.2
Noise Immunity	NEMA ICS3-304

One count in the specification table is equal to one least significant bit of the analog data value (1 in 4096).

### Analog Input Configuration Requirements

The F2-08AD-1 Analog Input appears as a 16-point discrete input module. The module can be installed in any slot of a DL205 system. The available power budget and discrete I/O points are the limiting factors. Check the user manual for your particular model of CPU and I/O base for more information regarding power budget and number of local, local expansion or remote I/O points.

**Special Placement Requirements (DL230 and Remote I/O Bases)**

Even though the module can be placed in any slot, it is important to examine the configuration if you are using a DL230 CPU. As you will see in the section on writing the program, you use V-memory locations to extract the analog data. If you place the module so that the input points do not start on a V-memory boundary, the instructions cannot access the data. This also applies when placing this module in a remote base using a D2-RSSS in the CPU slot.

**Correct!**

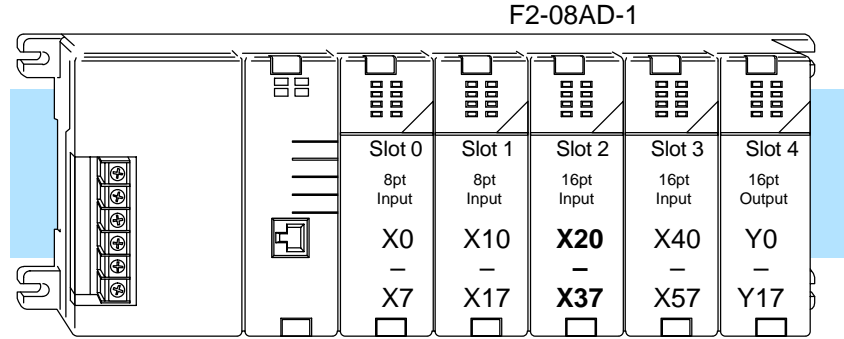

Data is correctly entered so input points start on a V-memory boundary.

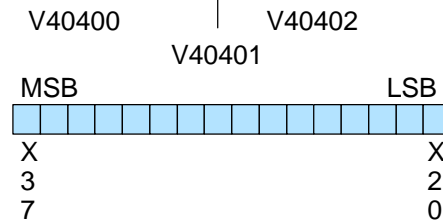

**Incorrect**

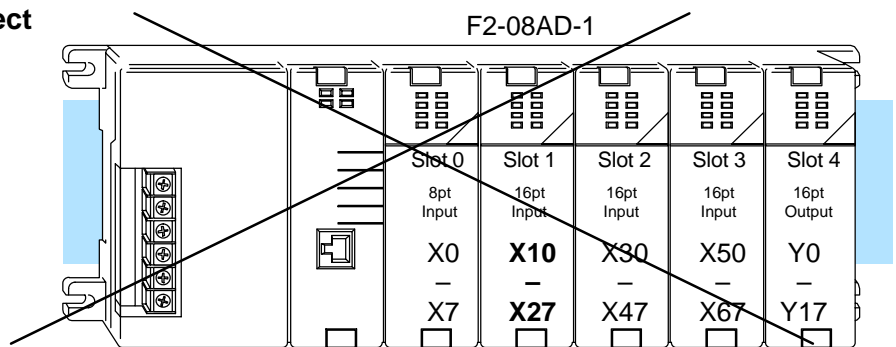

Data is split over two locations, so instructions cannot access data from a DL230.



To use the V-memory references required for a DL230 CPU, the *first* input address assigned to the module must be one of the following X locations. The table also shows the V-memory addresses that correspond to these X locations.

<b>X</b>	X0	X20	X40	X60	X100	X120	X140	X160
<b>V</b>	V40400	V40401	V40402	V40403	V40404	V40405	V40406	V40407

## Setting the Module Jumpers

### Selecting the Number of Channels

There are three jumpers, labeled +1, +2, and +4 that are used to select the number of channels that will be used. These jumpers are located on the motherboard, the one *with* the black D-shell style backplane connector. The module is set from the factory for eight channel operation (all three jumpers installed).

Any unused channels are not processed. For example, if you only select channels 1 thru 3, channels 4 thru 8 will not be active. The following table shows how to set the jumpers to select the number of channels.

No. of Channels	+1	+2	+4
1	No	No	No
1,2	Yes	No	No
1,2,3	No	Yes	No
1,2,3,4	Yes	Yes	No
1,2,3,4,5	No	No	Yes
1,2,3,4,5,6	Yes	No	Yes
1,2,3,4,5,6,7	No	Yes	Yes
1,2,3,4,5,6,7,8	Yes	Yes	Yes

Yes = jumper installed

No = jumper removed

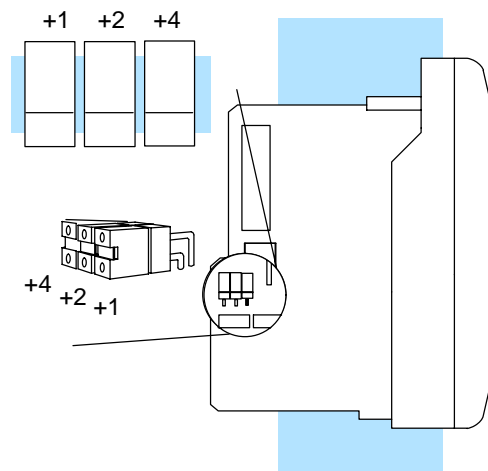

For example, to select 8-channel operation, leave all three jumpers installed. To select only channel 1, remove (or store on a single post to prevent losing them) all three jumpers.

## Connecting the Field Wiring

**Wiring Guidelines** Your company may have guidelines for wiring and cable installation. If so, you should check those before you begin the installation. Here are some general things to consider:

- Use the shortest wiring route whenever possible.
- Use shielded wiring and ground the shield at the transmitter source. *Do not* ground the shield at both the module and the source.
- Do not run the signal wiring next to large motors, high current switches, or transformers. This may cause noise problems.
- Route the wiring through an approved cable housing to minimize the risk of accidental damage. Check local and national codes to choose the correct method for your application.

### User Power Supply Requirements

The F2-08AD-1 requires at least one field-side power supply. You may use the same or separate power sources for the module supply and the current transmitter supply. The module requires 18–26.4VDC, at 80 mA.

The DL205 bases have built-in 24 VDC power supplies that provide up to 300mA of current . You may use this instead of a separate supply if you are using only a couple of analog modules.

It is desirable in some situations to power the transmitters separately in a location remote from the PLC. This will work as long as the transmitter supply meets the voltage and current requirements, and the transmitter minus (–) side and the module supply's minus (–) side are connected together.



**WARNING:** If you are using the 24 VDC base power supply, make sure you calculate the power budget. Exceeding the power budget can cause unpredictable system operation that can lead to a risk of personal injury or damage to equipment.

The DL205 base has a switching type power supply. As a result of switching noise, you may notice  $\pm 3$ –5 counts of instability in the analog input data if you use the base power supply. If this is unacceptable, you should try one of the following.

1. Use a separate linear power supply.
2. Connect the 24VDC common to the frame ground, which is the screw terminal marked “G” on the base.

By using these methods, the input stability is rated at  $\pm 1$  count.

If you want to use a separate supply, choose one that meets the following requirements: 18–26.4 VDC, 80mA current.

### Current Loop Transmitter Impedance

Standard 4 to 20 mA transmitters and transducers can operate from a wide variety of power supplies. Not all transmitters are alike and the manufacturers often specify a minimum loop or load resistance that must be used with the transmitter.

The F2-08AD-1 provides 250 ohm resistance for each channel. If your transmitter requires a load resistance below 250 ohms, you do not have to make any adjustments. However, if your transmitter requires a load resistance higher than 250 ohms, you need to add a resistor in series with the module.

Consider the following example for a transmitter being operated from a 30 VDC supply with a recommended load resistance of 750 ohms. Since the module has a 250 ohm resistor, you need to add an additional resistor.

$$R = Tr - Mr$$

$$R = 750 - 250$$

$$R \geq 500$$

R – resistor to add  
Tr – Transmitter Requirement  
Mr – Module resistance (internal 250 ohms)

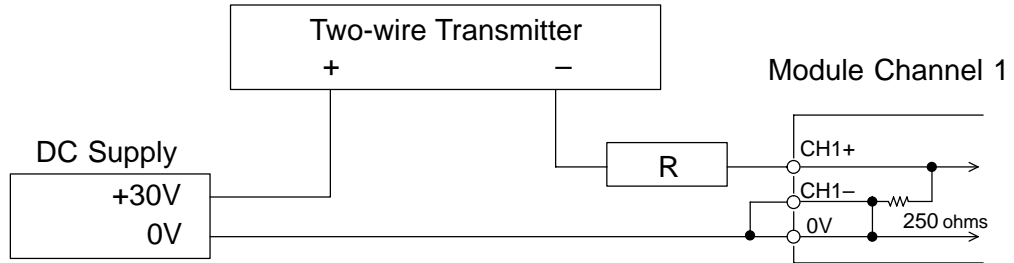

**Wiring Diagram**

The F2-08AD-1 module has a removable connector to make wiring easier. Simply squeeze the top and bottom retaining clips and gently pull the connector from the module. Use the following diagram to connect the field wiring. The diagram shows separate module and transmitter power supplies. If you desire to use only one field-side supply, just combine the supplies' positive (+) terminals into one node, and remove the transmitter supply.

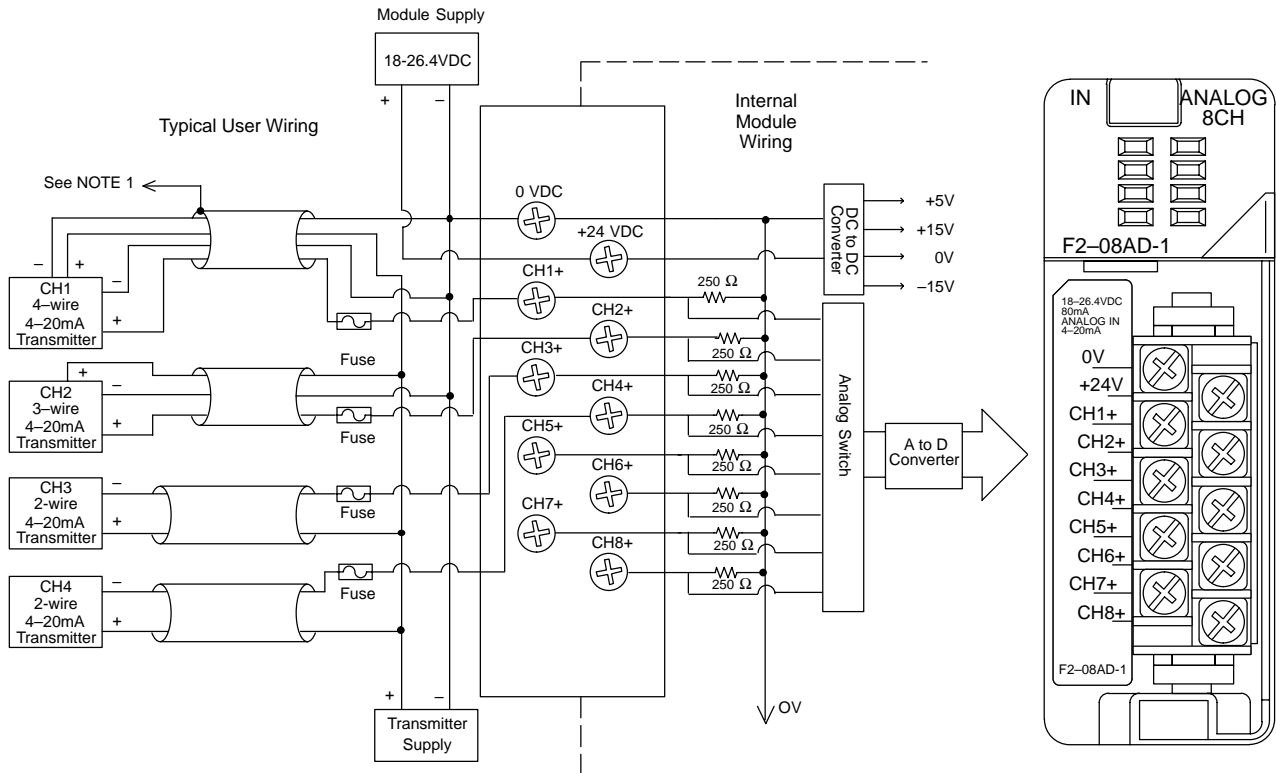

- NOTE 1: Shields should be grounded at the signal source.  
 NOTE 2: More than one external power supply can be used, provided all the power supply commons are connected.  
 NOTE 3: A Series 217, 0.032A fast-acting fuse is recommended for 4-20 mA current loops.  
 NOTE 4: If the power supply common of an external power supply is not connected to the 0V terminal on the module, then the output of the external transmitter must be isolated. To avoid "ground loop" errors, recommended 4-20 mA transmitter types are:
- For 2 or 3 wire connections: Isolation between the input supply signal and the power supply.
  - For 4 wire connections: Isolation between the input supply signal, the power supply, and the 4-20 mA output.

F2-08AD-1  
8-Ch. Current Input

## Module Operation

Before you begin writing the control program, it is important to take a few minutes to understand how the module processes and represents the analog signals.

### Channel Scanning Sequence for a DL230 CPU (Multiplexing)

The F2-08AD-1 module can supply different amounts of data per scan, depending on the type of CPU you are using. The DL230 can obtain one channel of data per CPU scan. Since there are eight channels, it can take up to eight scans to get data for all channels. Once all channels have been scanned the process starts over with channel 1. Unused channels are not processed, so if you select only two channels, then each channel will be updated every other scan. The multiplexing method can also be used for DL240/250-1/260 CPUs.

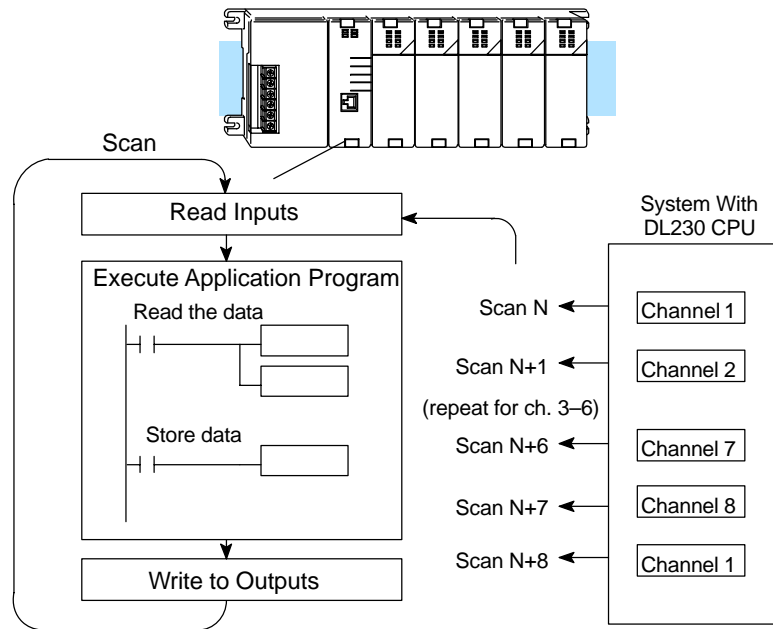

### Channel Scanning Sequence with a DL240, DL250-1 or DL260 CPU (Pointer Method)

If you are using a DL240/250-1/260 CPU, you can obtain all eight channels of input data in one scan. This is because the DL240, DL250-1 and DL260 CPUs support special V-memory locations that are used to manage the data transfer (this is discussed in more detail in the section on Writing the Control Program.)

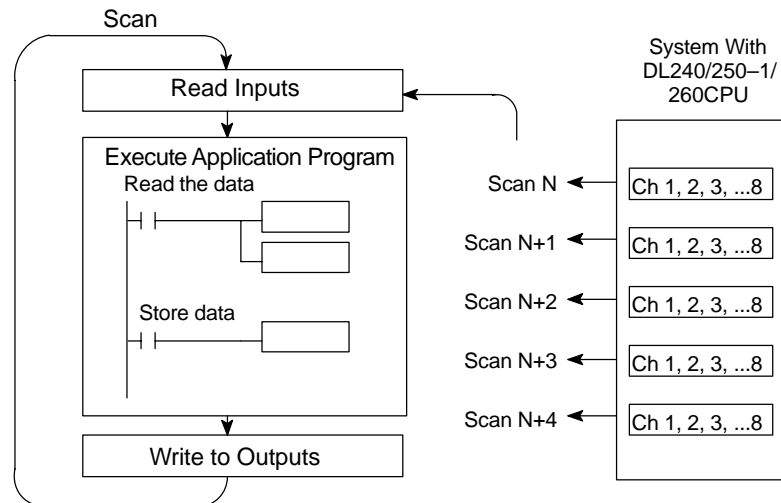

### Analog Module Updates

Even though the channel updates to the CPU are synchronous with the CPU scan, the module asynchronously monitors the analog transmitter signal and converts the signal to a 12-bit binary representation. This enables the module to continuously provide accurate measurements without slowing down the discrete control logic in the RLL program.

For the vast majority of applications, the values are updated much faster than the signal changes. However, in some applications the update time can be important. The module takes approximately 7mS to sense 95% of the change in the analog signal.

Note, this is *not* the amount of time required to convert the signal to a digital representation. The conversion to the digital representation takes only a few microseconds. Many manufacturers list the conversion time, but it is the settling time of the filter that really determines the update time.

### Understanding the Input Assignments

You may recall the F2-08AD-1 module requires 16 discrete input points in the CPU. You can use these points to obtain:

- an indication of which channel is active.
- the digital representation of the analog signal.
- module diagnostic information.

Since all input points are automatically mapped into V-memory, it is very easy to determine the location of the data word that will be assigned to the module.

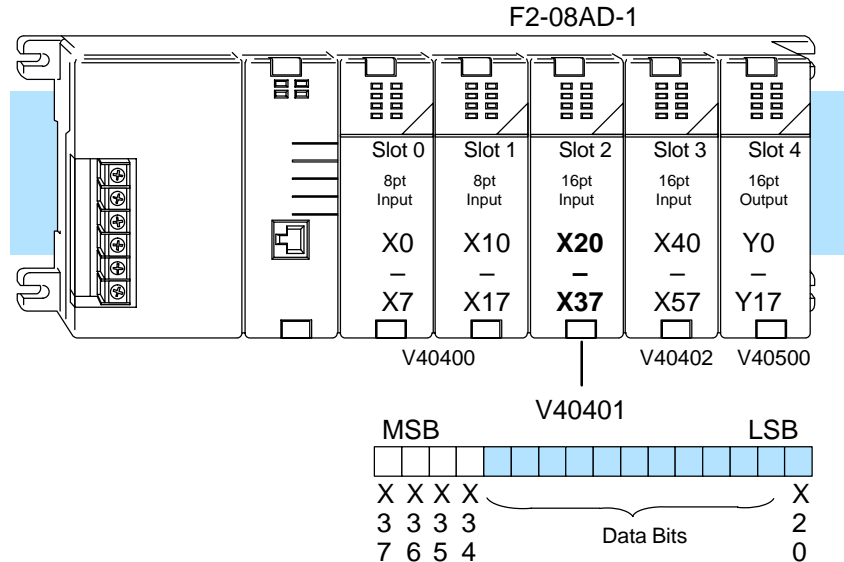

Within these word locations, the individual bits represent specific information about the analog signal.

### Analog Data Bits

The first twelve bits represent the analog data in binary format.

Bit	Value	Bit	Value
0	1	6	64
1	2	7	128
2	4	8	256
3	8	9	512
4	16	10	1024
5	32	11	2048

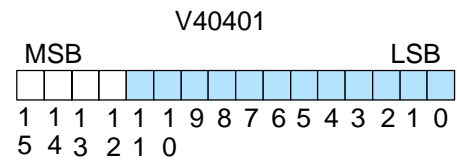

■ = data bits

**Active Channel Indicator Inputs** Three of the inputs are binary-encoded to indicate the active channel. (Remember, the V-memory bits are mapped directly to discrete inputs.) The inputs are automatically turned on and off to indicate the active channel for each scan.

Scan	X34	X35	X36	Channel
N	Off	Off	Off	1
N+1	On	Off	Off	2
N+2	Off	On	Off	3
N+3	On	On	Off	4
N+4	Off	Off	On	5
N +5	On	Off	On	6
N +6	Off	On	On	7
N +7	On	On	On	8

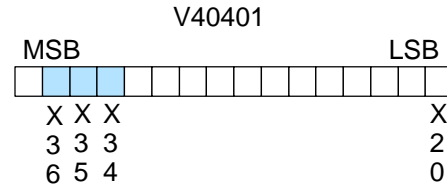

= channel inputs

**Module Diagnostic Inputs**

The last input (X37 in this example) is the broken transmitter and missing 24 volts input power indicator.

When X37 is on, the input transmitter maybe broken for the corresponding input.

If there is no external 24 volts input power, or if there is a loose or missing terminal block, then X37 goes on and a value of zero is returned for all enabled channels.

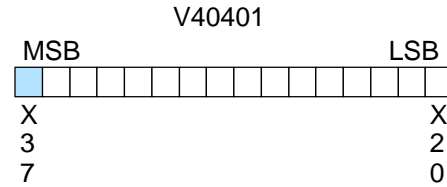

= diagnostic inputs

**Module Resolution**

Since the module has 12-bit resolution, the analog signal is converted into 4096 counts ranging from 0 – 4095 (2<sup>12</sup>). For example, a 4mA signal would be 0 and a 20mA signal would be 4095. This is equivalent to a binary value of 0000 0000 to 1111 1111 1111, or 000 to FFF hexadecimal. The diagram shows how this relates to the signal range.

Each count can also be expressed in terms of the signal level by using the equation shown.

4 – 20mA

Resolution =  $\frac{H - L}{4095}$

H = high limit of the signal range  
L = low limit of the signal range

16mA / 4095 = 3.907mA per count

# Writing the Control Program

## Reading Values: Pointer Method and Multiplexing

There are two methods of reading values:

- The pointer method
- Multiplexing

You *must* use the multiplexing method when using a DL230 CPU. You must also use the multiplexing method with remote I/O modules (the pointer method will not work). You can use either method when using DL240, DL250-1 and DL260 CPUs, but for ease of programming it is strongly recommended that you use the pointer method.

### Pointer Method

×	✓	✓	✓
230	240	250-1	260



The DL205 series has special V-memory locations (shown in the tables on the next page) that are assigned to each base slot that greatly simplify the programming requirements. These V-memory locations allow you to:

- specify the data format
- specify the number of channels to scan
- specify the storage locations

**NOTE:** DL240 CPUs with firmware release 2.2 or later supports this method. DL250 CPUs with firmware release version 1.06 or later support this method. If you must use the DL230 example, module placement in the base is very important. Review the section earlier in this chapter for guidelines.

The example program below shows how to setup these locations. Place this rung anywhere in the ladder program or in the Initial Stage if you are using RLL<sup>PLUS</sup> instructions. This is all that is required to read the data into V-memory locations. Once the data is in V-memory, you can perform math on the data, compare the data against preset values, and so forth. V2000 is used in the example, but you can use any user V-memory location. In this example the module is installed in slot 2. You should use the V-memory locations for your module placement. The pointer method automatically converts values to BCD.

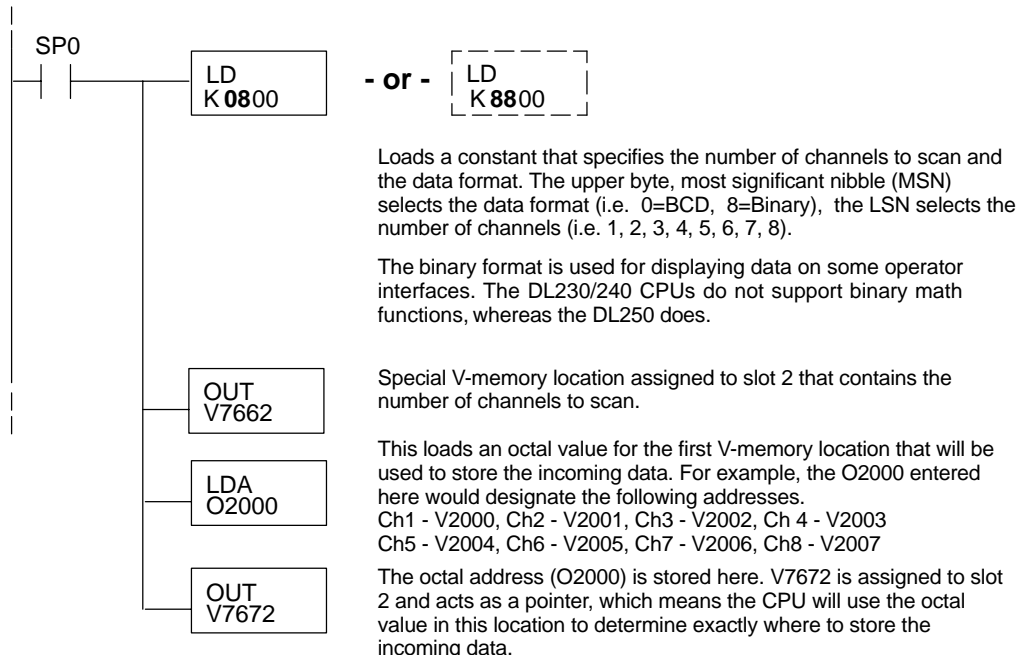

The tables below show the special V-memory locations used by the DL240, DL250–1 and DL260 for the CPU base and local expansion base I/O slots. Slot 0 (zero) is the module next to the CPU or D2–CM module. Slot 1 is the module two places from the CPU or D2–CM, and so on. Remember, the CPU only examines the pointer values at these locations after a mode transition. Also, if you use the DL230 (multiplexing) method, verify that these addresses in the CPU are zero.

The Table below applies to the DL240, DL250–1 and DL260 CPU base.

<b>CPU Base: Analog Input Module Slot-Dependent V-memory Locations</b>								
Slot	0	1	2	3	4	5	6	7
No. of Channels	V7660	V7661	V7662	V7663	V7664	V7665	V7666	V7667
Storage Pointer	V7670	V7671	V7672	V7673	V7674	V7675	V7676	V7677

The Table below applies to the DL250–1 or DL260 expansion base 1.

<b>Expansion Base D2–CM #1: Analog Input Module Slot-Dependent V-memory Locations</b>								
Slot	0	1	2	3	4	5	6	7
No. of Channels	V36000	V36001	V36002	V36003	V36004	V36005	V36006	V36007
Storage Pointer	V36010	V36011	V36012	V36013	V36014	V36015	V36016	V36017

The Table below applies to the DL250–1 or DL260 expansion base 2.

<b>Expansion Base D2–CM #2: Analog Input Module Slot-Dependent V-memory Locations</b>								
Slot	0	1	2	3	4	5	6	7
No. of Channels	V36100	V36101	V36102	V36103	V36104	V36105	V36106	V36107
Storage Pointer	V36110	V36111	V36112	V36113	V36114	V36115	V36116	V36117

The Table below applies to the DL260 CPU expansion base 3.

<b>Expansion Base D2–CM #3: Analog Input Module Slot-Dependent V-memory Locations</b>								
Slot	0	1	2	3	4	5	6	7
No. of Channels	V36200	V36201	V36202	V36203	V36204	V36205	V36206	V36207
Storage Pointer	V36210	V36211	V36212	V36213	V36214	V36215	V36216	V36217

The Table below applies to the DL260 CPU expansion base 4.

<b>Expansion Base D2–CM #4: Analog Input Module Slot-Dependent V-memory Locations</b>								
Slot	0	1	2	3	4	5	6	7
No. of Channels	V36300	V36301	V36302	V36303	V36304	V36305	V36306	V36307
Storage Pointer	V36310	V36311	V36312	V36313	V36314	V36315	V36316	V36317

### Reading Values Multiplexing



The DL230 CPU *does not* have the special V-memory locations that allow you to automatically enable the data transfer. Since all channels are multiplexed into a single data word, the control program must be setup to determine which channel is being read. Since the module appears as X input points to the CPU, it is very easy to use the active channel status bits to determine which channel is being monitored.

Note, this example is for a module installed as shown in the previous examples. The addresses used would be different if the module was installed in another I/O configuration. You can place these rungs anywhere in the program or if you are using stage programming place them in a stage that is always active.

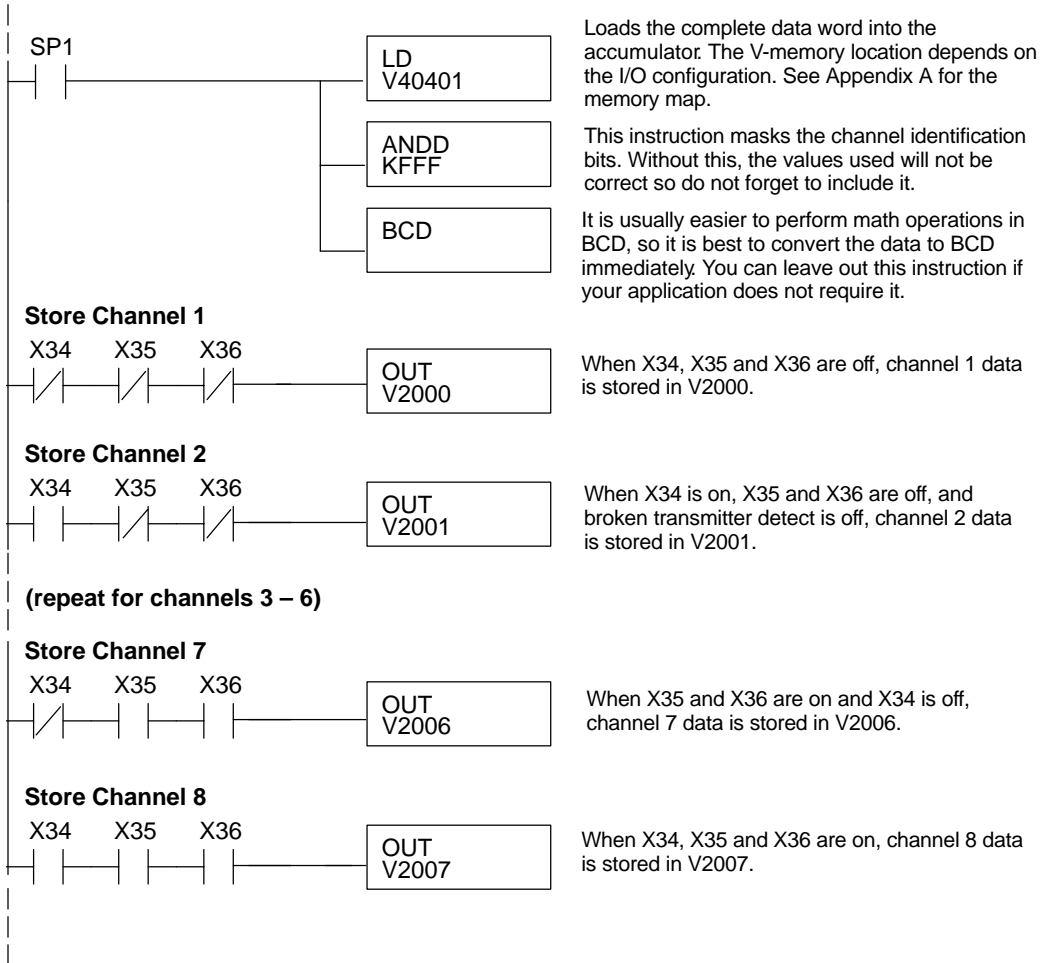

**Single Channel Selected**

Since you do not have to determine which channel is selected, the single channel program is even more simple.

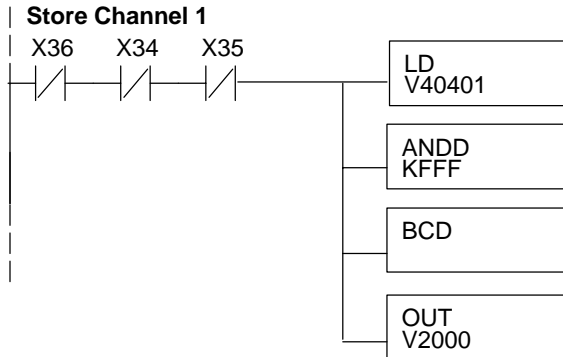

Loads the complete data word into the accumulator. The V-memory location depends on the I/O configuration. See Appendix A for the memory map.

This instruction masks the channel identification bits. Without this, the values used will not be correct, so do not forget to include it. It is usually easier to perform math operations in BCD, so it is best to convert the data to BCD immediately. You can leave out this instruction if your application does not require it.

When X34, X35 and X36 are off, channel 1 data is stored in V2000.

**Analog Power Failure Detection**

The analog module has an on-board processor that can diagnose analog input circuit problems. You can easily create a simple ladder rung to detect these problems. This rung shows an input point that would be assigned if the module I/O begins at X20 as shown in the previous examples. A different point would be used if the module was installed in a different I/O arrangement.

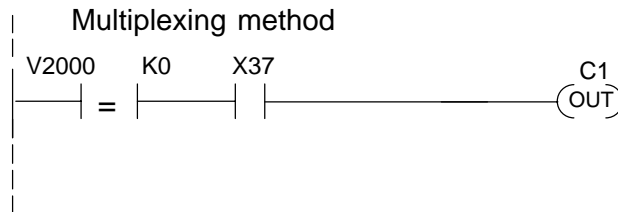

V-memory location V2000 holds channel 1 data. When a data value of zero is returned and input X37 is on, then the analog circuitry is not operating properly.

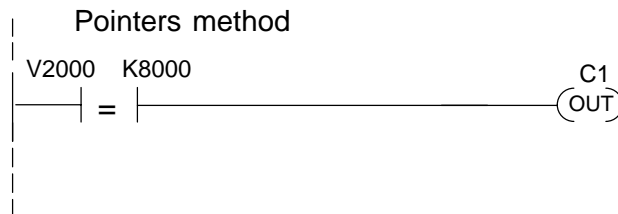

V-memory location V2000 holds channel 1 data. When a data value of 8000 is returned, then the analog circuitry is not operating properly.

**Scaling the Input Data**

Most applications usually require measurements in engineering units, which provide more meaningful data. This is accomplished by using the conversion formula shown.

You may have to make adjustments to the formula depending on the scale you choose for the engineering units.

$$\text{Units} = A \frac{H - L}{4095}$$

H = high limit of the engineering unit range

L = low limit of the engineering unit range

A = Analog value (0 – 4095)

For example, if you wanted to measure pressure (PSI) from 0.0 to 99.9 then you would have to multiply the analog value by 10 in order to imply a decimal place when you view the value with the programming software or a handheld programmer. Notice how the calculations differ when you use the multiplier.

Analog value of 2024, slightly less than half scale, should yield 49.4 PSI

Example without multiplier

$$\text{Units} = A \frac{H - L}{4095}$$

$$\text{Units} = 2024 \frac{100 - 0}{4095}$$

$$\text{Units} = 49$$

Handheld Display

V 2001	V 2000
0000	0049

Example with multiplier

$$\text{Units} = 10 A \frac{H - L}{4095}$$

$$\text{Units} = 20240 \frac{100 - 0}{4095}$$

$$\text{Units} = 494$$

Handheld Display

V 2001	V 2000
0000	0494

This value is more accurate.

Here is how you would write the program to perform the engineering unit conversion. Note, this example will work with all DL205 CPUs, but it assumes you have already loaded the BCD data into the appropriate V-memory locations using instructions that apply for the model of CPU you are using.

Note, this example uses SP1, which is always on. You could also use an X, C, etc. permissive contact.

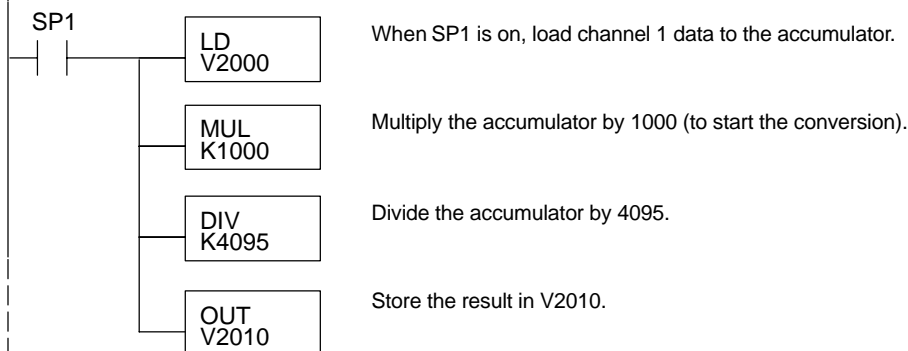

### Analog and Digital Value Conversions

Sometimes it is useful to be able to quickly convert between the signal levels and the digital values. This is especially helpful during machine startup or troubleshooting. The following table provides formulas to make this conversion easier.

Range	If you know the digital value...	If you know the analog signal level...
4 to 20mA	$A = \frac{16D}{4095} + 4$	$D = \frac{4095}{16}(A - 4)$

For example, if you have measured the signal as 10mA, you can use the formula to easily determine the digital value that will be stored in the V-memory location that contains the data.

$$D = \frac{4095}{16}(A - 4)$$

$$D = \frac{4095}{16}(10\text{mA} - 4)$$

$$D = (255.93) (6)$$

$$D = 1536$$

**Filtering Input Noise (DL250-1, DL260 CPU Only)**

✗	✗	✓	✓
230	240	250-1	260



Add the following logic to filter and smooth analog input noise in DL250-1 and DL260 CPUs. This is especially useful when using PID loops. Noise can be generated by the field device and/or induced by field wiring.

The analog value in BCD is first converted to a binary number because there is not a BCD-to-real conversion instruction. Memory location V1400 is the designated workspace in this example. The MULR instruction is the filter factor, which can be from 0.1 to 0.9. The example uses 0.2. A smaller filter factor increases filtering. You can use a higher precision value, but it is not generally needed. The filtered value is then converted back to binary and then to BCD. The filtered value is stored in location V1402 for use in your application or PID loop.

**NOTE:** Be careful not to do a multiple number conversion on a value. For example, if you are using the pointer method to get the analog value, it is in BCD and must be converted to binary. However, if you are using the conventional method of reading analog and are masking the first twelve bits, then it is already in binary and no conversion using the BIN instruction is needed.

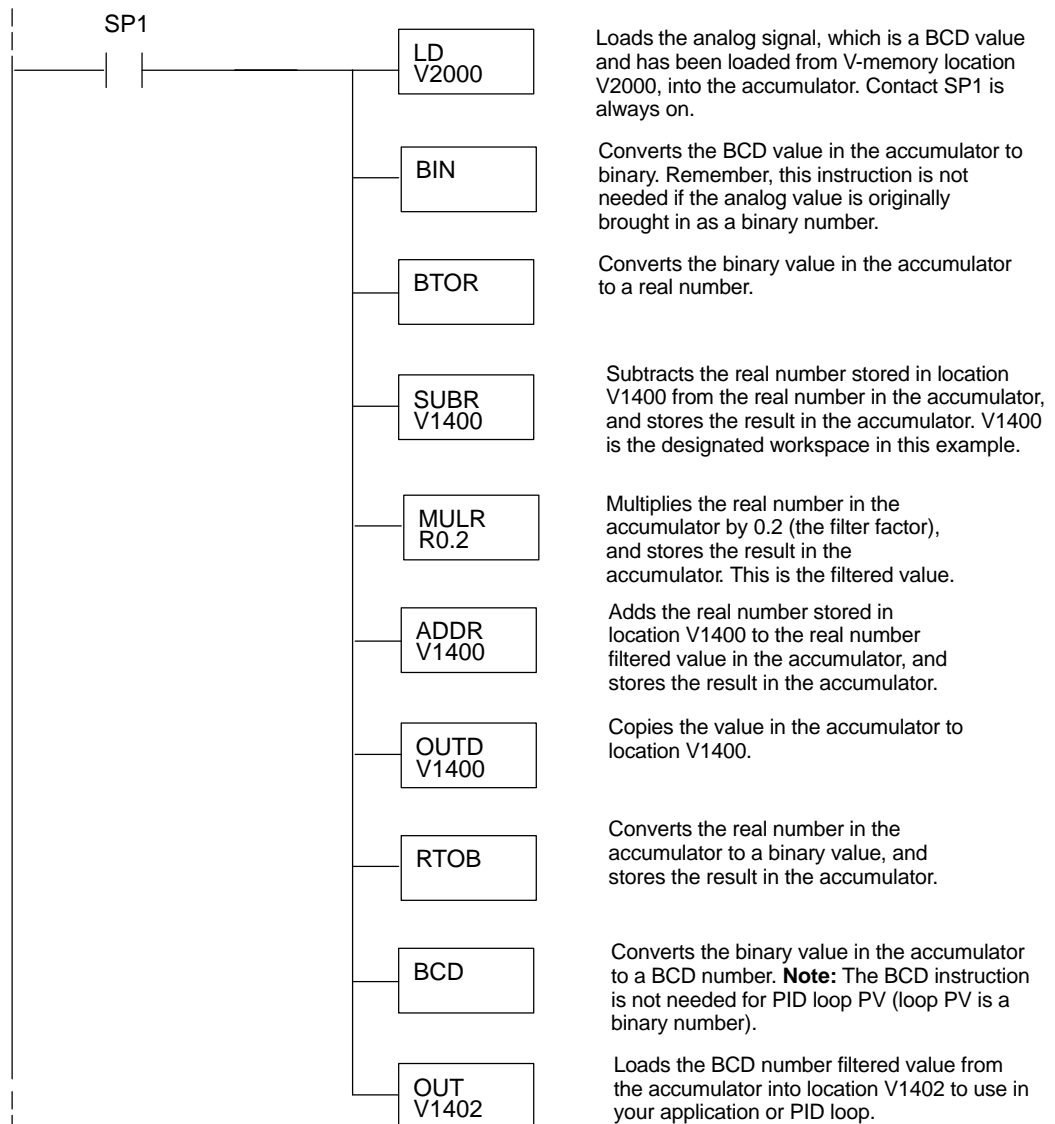

# F2-08AD-2

## 8-Channel Analog Voltage Input

---

In This Chapter. . . .

- Module Specifications
  - Setting the Module Jumpers
  - Connecting the Field Wiring
  - Module Operation
  - Writing the Control Program
-

## Module Specifications

The F2-08AD-2 Analog Voltage Input module provides several hardware features:

- Analog inputs are optically isolated from the PLC logic.
- The module has a removable terminal block so the module can be easily removed or changed without disconnecting the wiring.
- With a DL240, DL250-1 or DL260 CPU, you can update all channels in one scan.
- Low-power CMOS design requires less than 80mA from an external 18–26.4 VDC power supply.

### Firmware Requirements:

To use this module, D2-230 CPUs must have firmware version 1.6 or later. To use the pointer method of writing values, D2-240 CPUs require firmware version 2.2 or later and D2-250 CPUs require firmware version 1.06 or later.

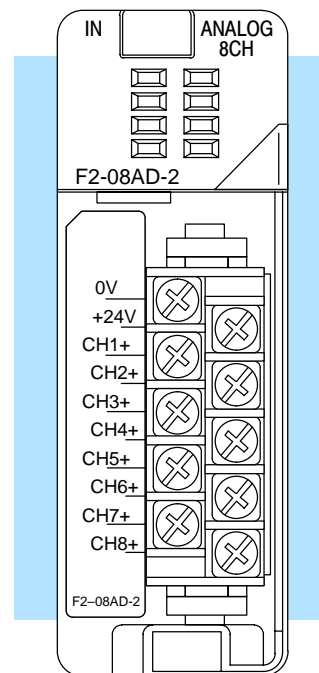

The following tables provide the specifications for the F2-08AD-2 Analog Input Module. Review these specifications to make sure the module meets your application requirements.

### Input Specifications

Number of Channels	8, single ended (one common)
Input Ranges	0 - 5V, 0 - 10V, $\pm 5V$ , $\pm 10V$ .
Resolution	12 bit (1 in 4096) unipolar (0 – 4095) 13 bit (1 in 8192) bipolar ( $-4095$ – $+4095$ )
Step Response	4 mS to 95% of full step change
Crosstalk	$-70$ dB, 1 count maximum
Input Filtering	$f_{-3dB}$ @ 200Hz, -6 dB / octave
Input Impedance	$> 20M\Omega$
Maximum Continuous Overload	$-75$ VDC to $+75$ VDC
Linearity Error (End to End)	$\pm 0.025\%$ of span ( $\pm 1$ count maximum unipolar) ( $\pm 2$ count maximum bipolar)
Input Stability	$\pm 1$ count
Full Scale Calibration Error (Offset error not included)	$\pm 3$ counts maximum
Offset Calibration Error	$\pm 1$ count maximum, @ 0 VDC
Maximum Inaccuracy	$\pm .1\%$ @ $25^{\circ}C$ $\pm .3\%$ 0 to $60^{\circ}C$ (32 to $140^{\circ}F$ )
Accuracy vs. Temperature	$\pm 50$ ppm/ $^{\circ}C$ maximum full scale calibration (including maximum offset change of 2 counts)

### General Specifications

PLC Update Rate	1 channel per scan maximum (DL230 CPU) 8 channels per scan maximum (DL240/250–1/260 CPU)
Data Acquisition Time	3ms/channel (asynchronous)
Digital Inputs	12 binary data bits, 1 sign bit, 3 channel ID bits, 1 diagnostic bit
Input points required	16 point (X) input module
Power Budget Requirement	60 mA maximum, 5 VDC (supplied by base)
External Power Supply	80 mA maximum, 18 to 26.4 VDC
Operating Temperature	0 to $60^{\circ}C$ (32 to $140^{\circ}F$ )
Storage Temperature	$-20$ to $70^{\circ}C$ ( $-4$ to $158^{\circ}F$ )
Relative Humidity	5 to 95% (non-condensing)
Environmental air	No corrosive gases permitted
Vibration	MIL STD 810C 514.2
Shock	MIL STD 810C 516.2
Noise Immunity	NEMA ICS3–304

One count in the specification table is equal to one least significant bit of the analog data value (1 in 4096).

### Analog Input Configuration Requirements

The F2-08AD-2 Analog Input appears as a 16-point discrete input module. The module can be installed in any slot of a DL205 system. The available power budget and discrete I/O points are the limiting factors. Check the user manual for your particular model of CPU and I/O base for more information regarding power budget and number of local, local expansion or remote I/O points.

**Special Placement Requirements (DL230 and Remote I/O Bases)**

Even though the module can be placed in any slot, it is important to examine the configuration if you are using a DL230 CPU. As you will see in the section on writing the program, you use V-memory locations to extract the analog data. If you place the module so that the input points do not start on a V-memory boundary, the instructions cannot access the data. This also applies when placing this module in a remote base using a D2-RSSS in the CPU slot.

**Correct!**

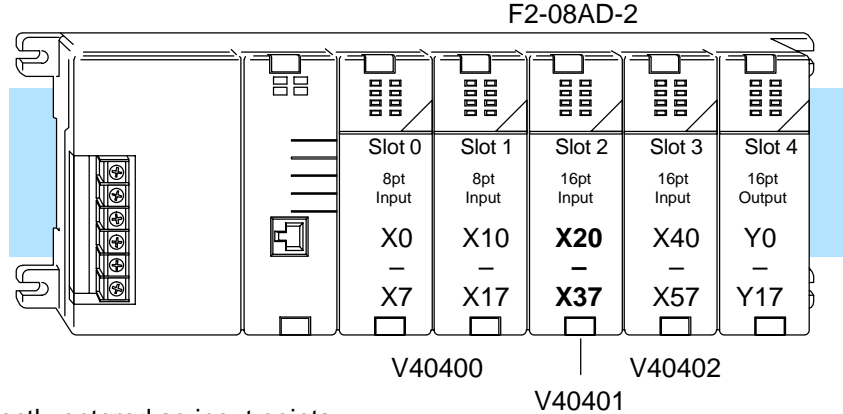

Data is correctly entered so input points start on a V-memory boundary.

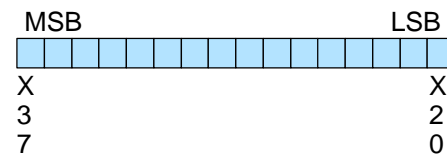

**Incorrect**

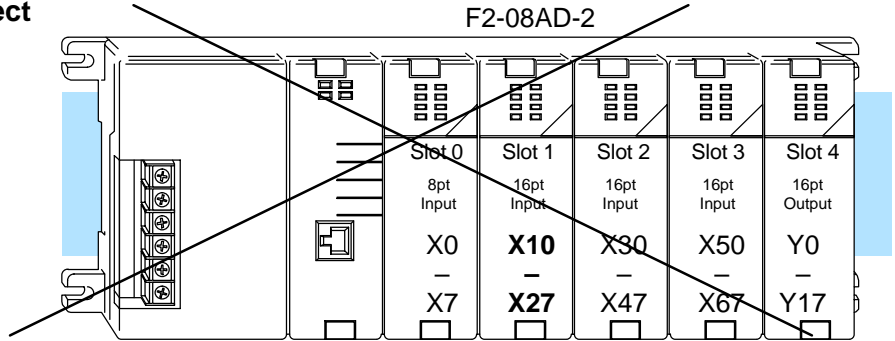

Data is split over two locations, so instructions cannot access data from a DL230.

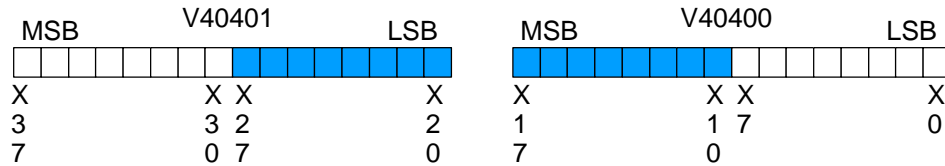

To use the required V-memory references, the *first* input address assigned to the module must be one of the following X locations. The table also shows the V-memory addresses that correspond to these X locations.

<b>X</b>	X0	X20	X40	X60	X100	X120	X140	X160
<b>V</b>	V40400	V40401	V40402	V40403	V40404	V40405	V40406	V40407

## Setting the Module Jumpers

### Selecting the Number of Channels

There are three jumpers, labeled +1, +2, and +4 that are used to select the number of channels that will be used. These jumpers are located on the motherboard, the one *with* the black D-shell style backplane connector. The module is set from the factory for eight channel operation (all three jumpers installed).

Any unused channels are not processed. For example, if you only select channels 1 thru 3, channels 4 thru 8 will not be active. The following table shows how to set the jumpers to select the number of channels.

No. of Channels	+1	+2	+4
1	No	No	No
1,2	Yes	No	No
1,2,3	No	Yes	No
1,2,3,4	Yes	Yes	No
1,2,3,4,5	No	No	Yes
1,2,3,4,5,6	Yes	No	Yes
1,2,3,4,5,6,7	No	Yes	Yes
1,2,3,4,5,6,7,8	Yes	Yes	Yes

Yes = jumper installed

No = jumper removed

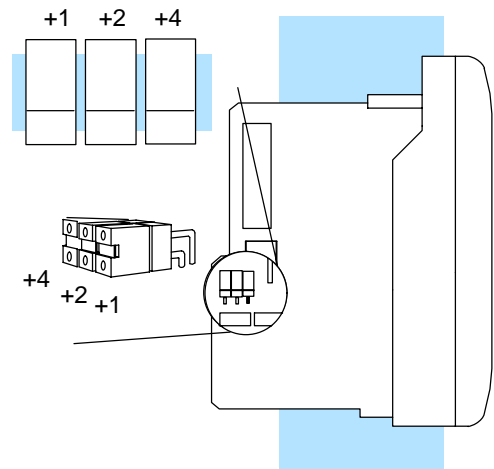

For example, to select 8-channel operation, leave all three jumpers installed. To select only channel 1, remove (or store on a single post to prevent losing them) all three jumpers.

### Selecting Input Voltage Range

If you examine the smaller circuit board, which is on top of the motherboard, you will notice a jumper labeled "J3." Use this jumper to select between the 5V ranges and the 10V ranges. The module comes from the factory set for 10V operation (jumper is removed and is stored on one of the pins).

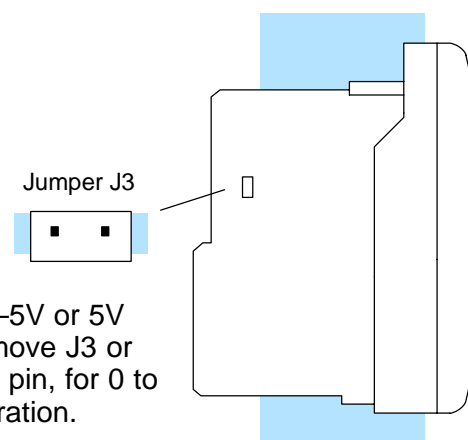

Install J3 for 0-5V or 5V operation. Remove J3 or store on single pin, for 0 to 10 or 10V operation.

## Connecting the Field Wiring

### Wiring Guidelines

Your company may have guidelines for wiring and cable installation. If so, you should check those before you begin the installation. Here are some general things to consider:

- Use the shortest wiring route whenever possible.
- Use shielded wiring and ground the shield at the transmitter source. *Do not* ground the shield at both the module and the source.
- Do not run the signal wiring next to large motors, high current switches, or transformers. This may cause noise problems.
- Route the wiring through an approved cable housing to minimize the risk of accidental damage. Check local and national codes to choose the correct method for your application.

### User Power Supply Requirements

You may use the same or separate power source for the transmitter voltage supply. The DL205 bases have built-in 24 VDC power supplies that provide up to 300mA of current. You may use this instead of a separate supply if you are using only a couple of analog modules.

It is desirable in some situations to power the transmitters separately in a location remote from the PLC. This will work as long as the transmitter supply meets the voltage and current requirements, and the transmitter's minus (–) side and the module supply's minus (–) side are connected together.

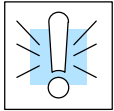

---

**WARNING:** If you are using the 24 VDC base power supply, make sure you calculate the power budget. Exceeding the power budget can cause unpredictable system operation that can lead to a risk of personal injury or damage to equipment.

---

The DL205 base has a switching type power supply. As a result of switching noise, you may notice  $\pm 3$ –5 counts of instability in the analog input data if you use the base power supply. If this is unacceptable, try one of the following:

1. Use a separate linear power supply.
2. Connect the 24VDC common to the frame ground, which is the screw terminal marked “G” on the base.

By using these methods, the input stability is rated at  $\pm 1$  count.

Unused inputs should be shorted together and connected to common.

**Wiring Diagram**

The F2-08AD-2 module has a removable connector to make wiring easier. Simply squeeze the top and bottom retaining clips and gently pull the connector from the module. Use the following diagram to connect the field wiring.

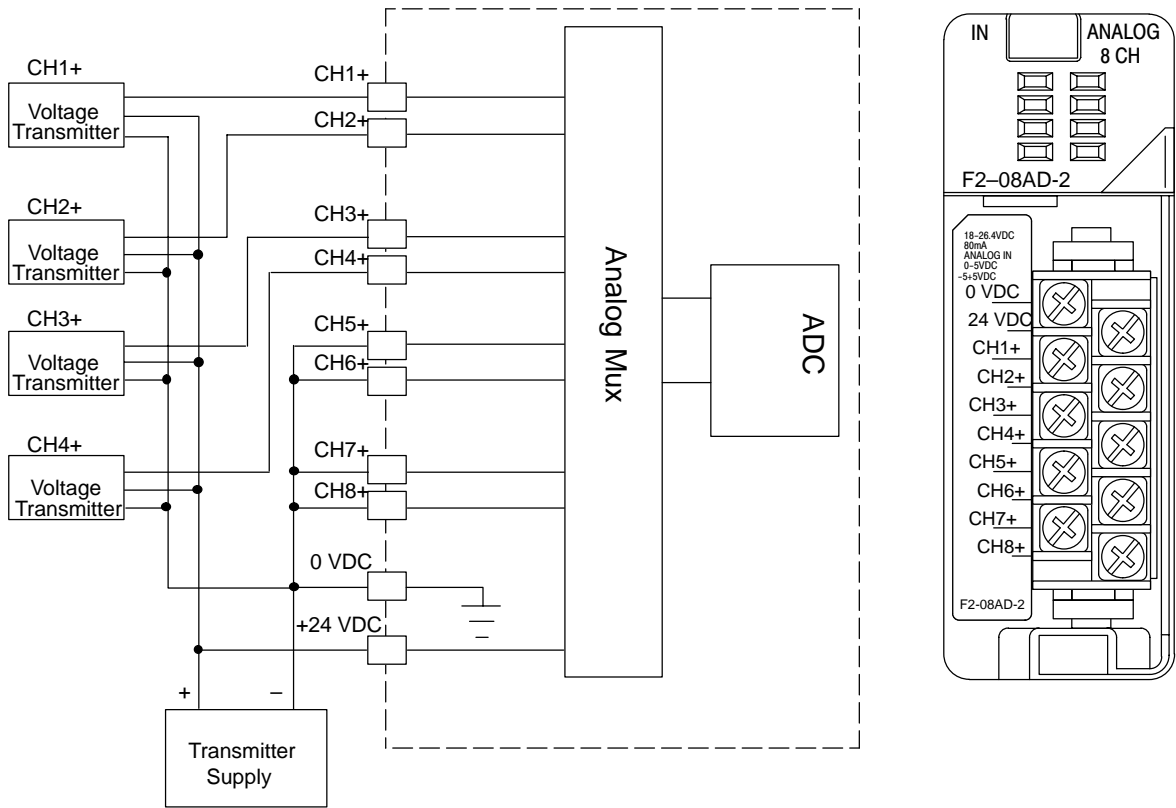

Note 1: Connect unused channels (CH5+, CH6+, CH7+, CH8+ in this diagram) to common (0 VDC).

# Module Operation

Before you begin writing the control program, it is important to take a few minutes to understand how the module processes and represents the analog signals.

## Channel Scanning Sequence for a DL230 CPU (Multiplexing)

The F2-08AD-2 module can supply different amounts of data per scan, depending on the type of CPU you are using. The DL230 can obtain one channel of data per CPU scan. Since there are eight channels, it can take up to eight scans to get data for all channels. Once all channels have been scanned the process starts over with channel 1. Unused channels are not processed, so if you select only two channels, then each channel will be updated every other scan. The multiplexing method can also be used for DL240/250-1/260 CPUs.

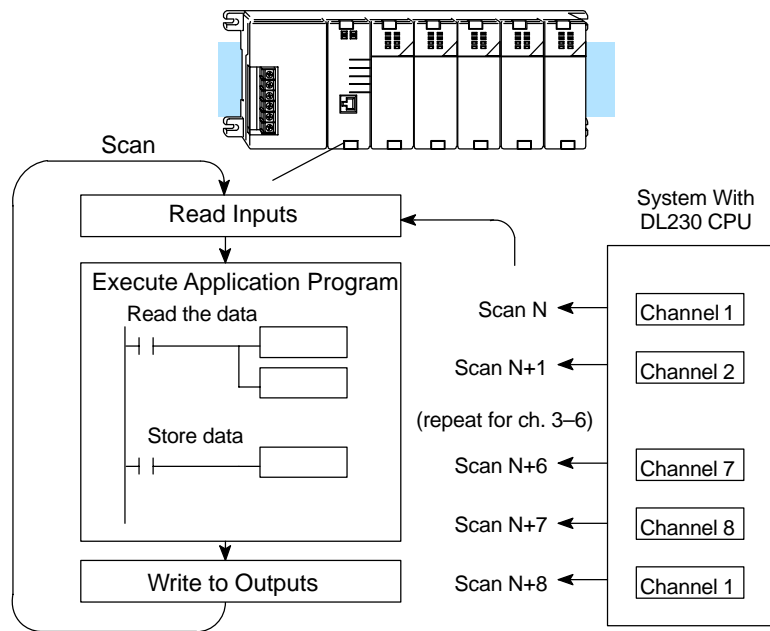

## Channel Scanning Sequence for a DL240, DL250-1 or DL260 CPU (Pointer Method)

If you are using a DL240, DL250-1 or DL260 CPU, you can obtain all eight channels of input data in one scan. This is because those CPUs support special V-memory locations that are used to manage the data transfer (this is discussed in more detail in the section on Writing the Control Program.)

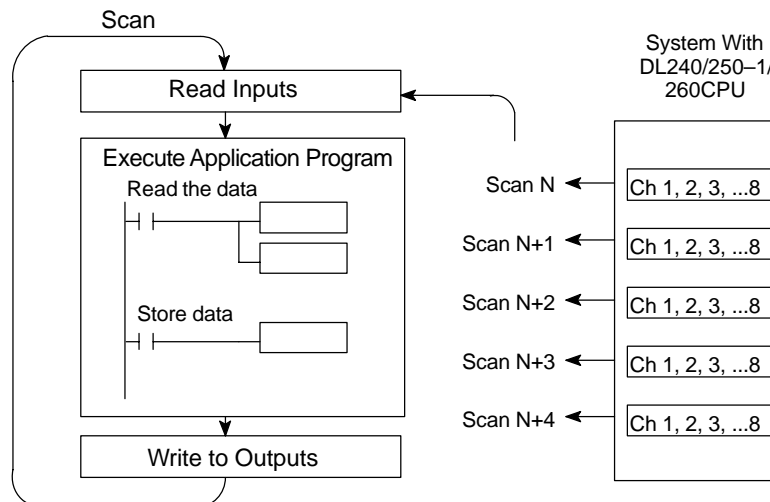

F2-08AD-2  
8-Ch. Voltage Input

**Analog Module Updates**

Even though the channel updates to the CPU are synchronous with the CPU scan, the module asynchronously monitors the analog transmitter signal and converts the signal to a 12-bit binary representation. This enables the module to continuously provide accurate measurements without slowing down the discrete control logic in the RLL program.

For the vast majority of applications, the values are updated much faster than the signal changes. However, in some applications the update time can be important. The module takes approximately 4ms to sense 95% of the change in the analog signal.

Note, this is *not* the amount of time required to convert the signal to a digital representation. The conversion to the digital representation takes only a few microseconds. Many manufacturers list the conversion time, but it is the settling time of the filter that really determines the update time.

**Understanding the Input Assignments**

You may recall the F2-08AD-2 module requires 16 discrete input points in the CPU. You can use these points to obtain:

- an indication of which channel is active.
- the digital representation of the analog signal.
- module diagnostic information.

Since all input points are automatically mapped into V-memory, it is very easy to determine the location of the data word that will be assigned to the module.

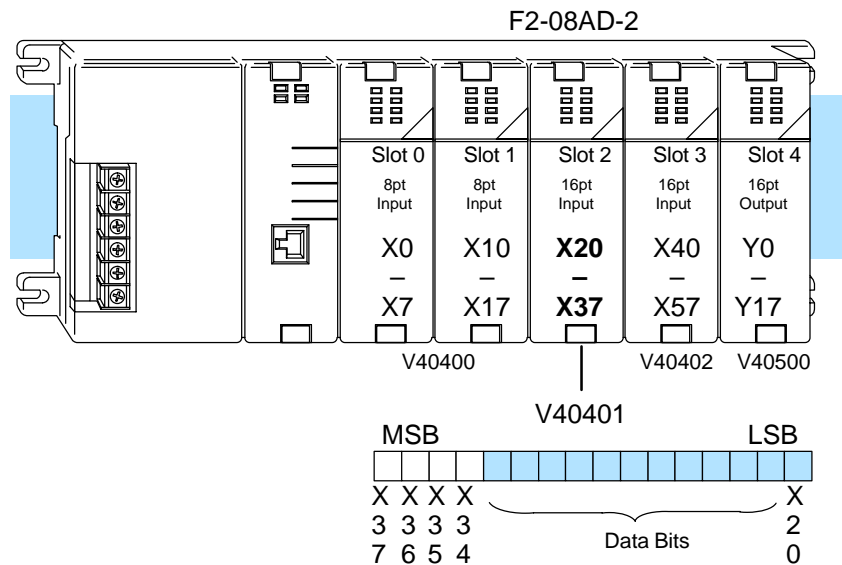

Within these word locations, the individual bits represent specific information about the analog signal.

**Analog Data Bits**

The first twelve bits represent the analog data in binary format.

Bit	Value	Bit	Value
0	1	6	64
1	2	7	128
2	4	8	256
3	8	9	512
4	16	10	1024
5	32	11	2048

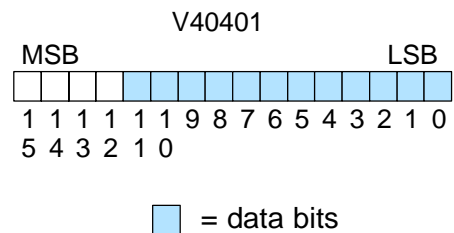

### Active Channel Indicator Inputs

Three of the inputs are binary-encoded to indicate the active channel. (remember, the V-memory bits are mapped directly to discrete inputs.) The inputs are automatically turned on and off to indicate the active channel for each scan.

Scan	X34	X35	X36	Channel
N	Off	Off	Off	1
N+1	On	Off	Off	2
N+2	Off	On	Off	3
N+3	On	On	Off	4
N+4	Off	Off	On	5
N +5	On	Off	On	6
N +6	Off	On	On	7
N +7	On	On	On	8

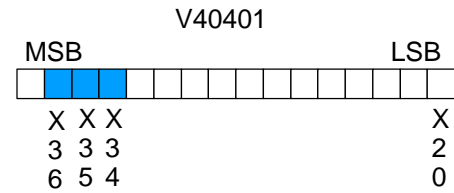

■ = channel inputs

### Module Diagnostic and Sign

The MSB input is the broken transmitter/ no 24 volts indicator and sign indicator.

If bit is on and the data is zero, there is no 24 volts input power or the terminal block is loose or missing. If the data is not zero then the input represents the sign bit.

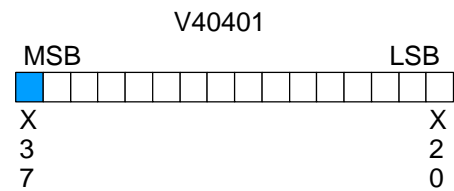

■ = diagnostic input / sign bit

### Module Resolution

Since the module has 12-bit unipolar resolution, the analog signal is converted into 4096 counts ranging from 0 – 4095 ( $2^{12}$ ). For example, with a 0 to 10V scale, a 0V signal would be 0, and a 10V signal would be 4095. This is equivalent to a binary value of 0000 0000 0000 to 1111 1111 1111, or 000 to FFF hexadecimal. The diagram shows how this relates to each signal range.

The bipolar ranges utilize a sign bit to provide 13-bit resolution. A value of 4095 can represent the upper limit of either side of the range. Use the sign bit to determine negative values.

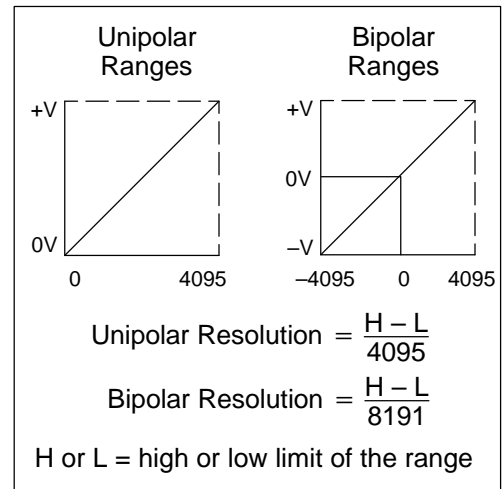

Each count can also be expressed in terms of the signal level by using the equation shown. The following table shows the smallest detectable signal change that will result in one LSB change in the data value for each input signal range.

Range	Signal Span (H – L)	Divide By	Smallest Detectable Change
0 to +10V	10V	4095	2.44 mV
-10 to +10V	20V	8191	2.44 mV
0 to +5V	5V	4095	1.22 mV
-5V to +5V	10V	8191	1.22 mV

# Writing the Control Program

## Reading Values: Pointer Method and Multiplexing

There are two methods of reading values:

- The pointer method
- Multiplexing

You *must* use the multiplexing method when using a DL230 CPU. You must also use the multiplexing method with remote I/O modules (the pointer method will not work). You can use either method when using DL240, DL250-1 and DL260 CPUs, but for ease of programming it is strongly recommended that you use the pointer method.

### Pointer Method

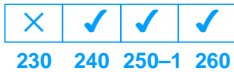

The DL240, DL250-1 and DL260 CPUs have special V-memory locations assigned to each base slot that greatly simplify the programming requirements. These V-memory locations:

- specify the data format.
- specify the number of channels to scan.
- specify the storage locations.

**NOTE:** DL240 CPUs with firmware release 2.2 or later supports this method. DL250 CPUs with firmware release version 1.06 or later support this method. If you must use the DL230 example, module placement in the base is very important. Review the section earlier in this chapter for guidelines.

The example program shows how to setup these locations. Place this rung anywhere in the ladder program or in the initial stage if you are using stage programming instructions. This is all that is required to read the data into V-memory locations. Once the data is in V-memory, you can perform math on the data, compare the data against preset values, and so forth. V2000 is used in the example, but you can use any user V-memory location. In this example the module is installed in slot 2. You should use the V-memory locations for your module placement. The pointer method automatically converts values to BCD.

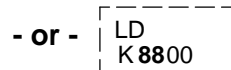
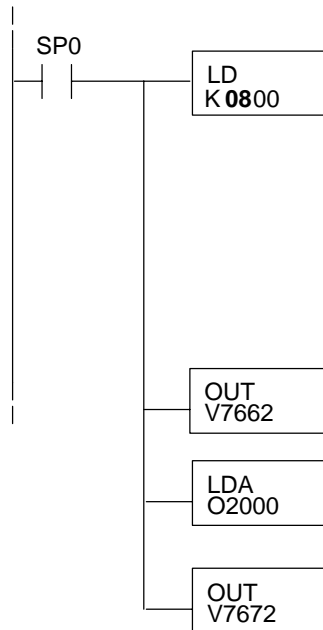

Loads a constant that specifies the number of channels to scan and the data format. The upper byte, most significant nibble (MSN) selects the data format (i.e. 0=BCD, 8=Binary), the LSN selects the number of channels (i.e. 1, 2, 3, 4, 5, 6, 7, or 8).

The binary format is used for displaying data on some operator interfaces. The DL230/240 CPUs do not support binary math functions, whereas the DL250 does.

Special V-memory location assigned to slot 2 that contains the number of channels to scan.

This loads an octal value for the first V-memory location that will be used to store the incoming data. For example, the O2000 entered here would designate the following addresses.

Ch1 - V2000, Ch2 - V2001, Ch3 - V2002, Ch4 - V2003  
Ch5 - V2004, Ch6 - V2005, Ch7 - V2006, Ch8 - V2007

The octal address (O2000) is stored here. V7672 is assigned to slot 2 and acts as a pointer, which means the CPU will use the octal value in this location to determine exactly where to store the incoming data.

The tables below show the special V-memory locations used by the DL240, DL250–1 and DL260 for the CPU base and local expansion base I/O slots. Slot 0 (zero) is the module next to the CPU or D2–CM module. Slot 1 is the module two places from the CPU or D2–CM, and so on. Remember, the CPU only examines the pointer values at these locations after a mode transition. Also, if you use the DL230 (multiplexing) method, verify that these addresses in the CPU are zero.

The Table below applies to the DL240, DL250–1 and DL260 CPU base.

<b>CPU Base: Analog Input Module Slot-Dependent V-memory Locations</b>								
Slot	0	1	2	3	4	5	6	7
No. of Channels	V7660	V7661	V7662	V7663	V7664	V7665	V7666	V7667
Storage Pointer	V7670	V7671	V7672	V7673	V7674	V7675	V7676	V7677

The Table below applies to the DL250–1 or DL260 expansion base 1.

<b>Expansion Base D2–CM #1: Analog Input Module Slot-Dependent V-memory Locations</b>								
Slot	0	1	2	3	4	5	6	7
No. of Channels	V36000	V36001	V36002	V36003	V36004	V36005	V36006	V36007
Storage Pointer	V36010	V36011	V36012	V36013	V36014	V36015	V36016	V36017

The Table below applies to the DL250–1 or DL260 expansion base 2.

<b>Expansion Base D2–CM #2: Analog Input Module Slot-Dependent V-memory Locations</b>								
Slot	0	1	2	3	4	5	6	7
No. of Channels	V36100	V36101	V36102	V36103	V36104	V36105	V36106	V36107
Storage Pointer	V36110	V36111	V36112	V36113	V36114	V36115	V36116	V36117

The Table below applies to the DL260 CPU expansion base 3.

<b>Expansion Base D2–CM #3: Analog Input Module Slot-Dependent V-memory Locations</b>								
Slot	0	1	2	3	4	5	6	7
No. of Channels	V36200	V36201	V36202	V36203	V36204	V36205	V36206	V36207
Storage Pointer	V36210	V36211	V36212	V36213	V36214	V36215	V36216	V36217

The Table below applies to the DL260 CPU expansion base 4.

<b>Expansion Base D2–CM #4: Analog Input Module Slot-Dependent V-memory Locations</b>								
Slot	0	1	2	3	4	5	6	7
No. of Channels	V36300	V36301	V36302	V36303	V36304	V36305	V36306	V36307
Storage Pointer	V36310	V36311	V36312	V36313	V36314	V36315	V36316	V36317

**Using Bipolar Ranges (Pointer Method)**

✗	✓	✓	✓
230	240	250-1	260

With bipolar ranges, you need some additional logic to determine whether the value being returned represents a positive or a negative voltage. For example, you may need to know the direction for a motor. With the pointer method, you *cannot* use the last input (X37 in the previous examples) to show the sign for each channel because the DL240/250-1/260 read all eight channels in one scan. If you tried to use X37, you would only be monitoring the last channel that was read. You would not be able to determine the sign for the previous channels. There is a simple solution:

- If you get a value greater than or equal to 8001, the value is negative.

The sign bit is the most significant bit, which combines 8000 to the data value. If the value is greater than or equal to 8001, you only have to mask the most significant bit and the active channel bits to determine the actual data value.

The following program shows how you can accomplish this. Since you always want to know when a value is negative, these rungs should be placed *before* any other operations that use the data, such as math instructions, scaling operations, and so forth. Also, if you are using stage programming instructions, these rungs should be in a stage that is always active. Note, you only need this logic for each channel that is using bipolar input signals. The example only shows two channels.

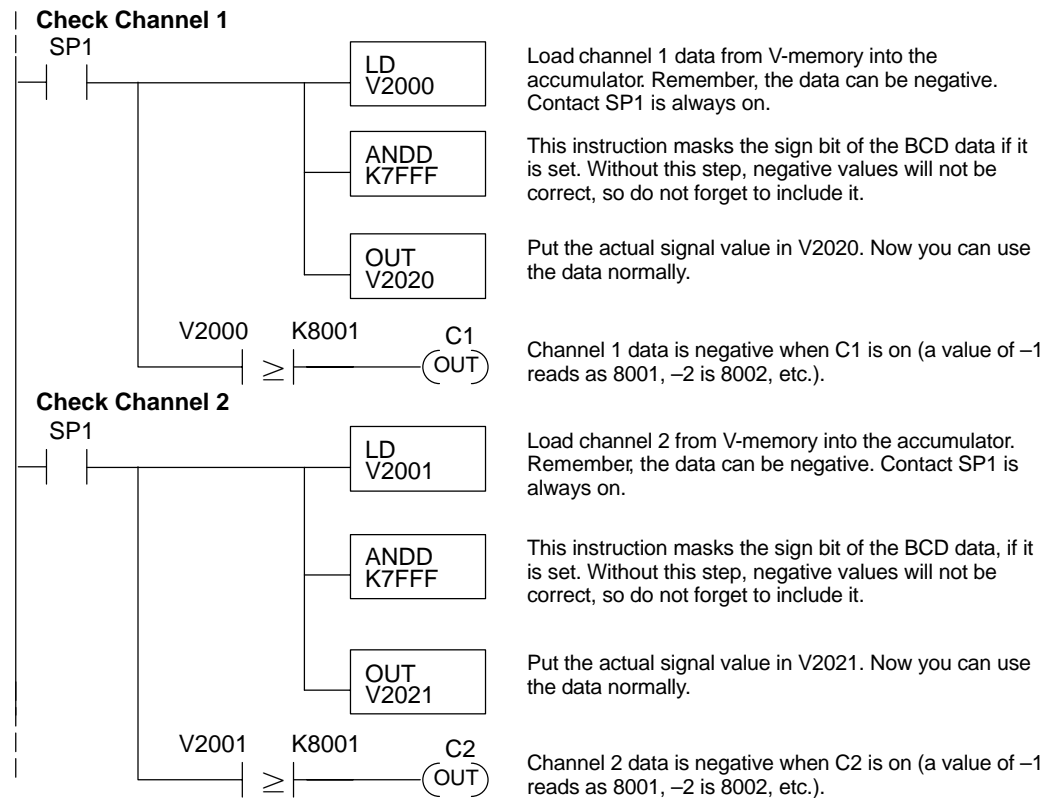

### Reading Values (Multiplexing)

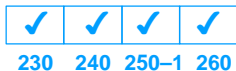

The DL230 CPU *does not* have the special V-memory locations that allow you to automatically enable the data transfer. Since all channels are multiplexed into a single data word, the control program must be setup to determine which channel is being read. Since the module appears as X input points to the CPU, it is very easy to use the active channel status bits to determine which channel is being monitored.

Note, this example is for a module installed as shown in the previous examples. The addresses used would be different if the module was used in a different slot. You can place these rungs anywhere in the program, or if you are using stage programming instructions place them in a stage that is always active.

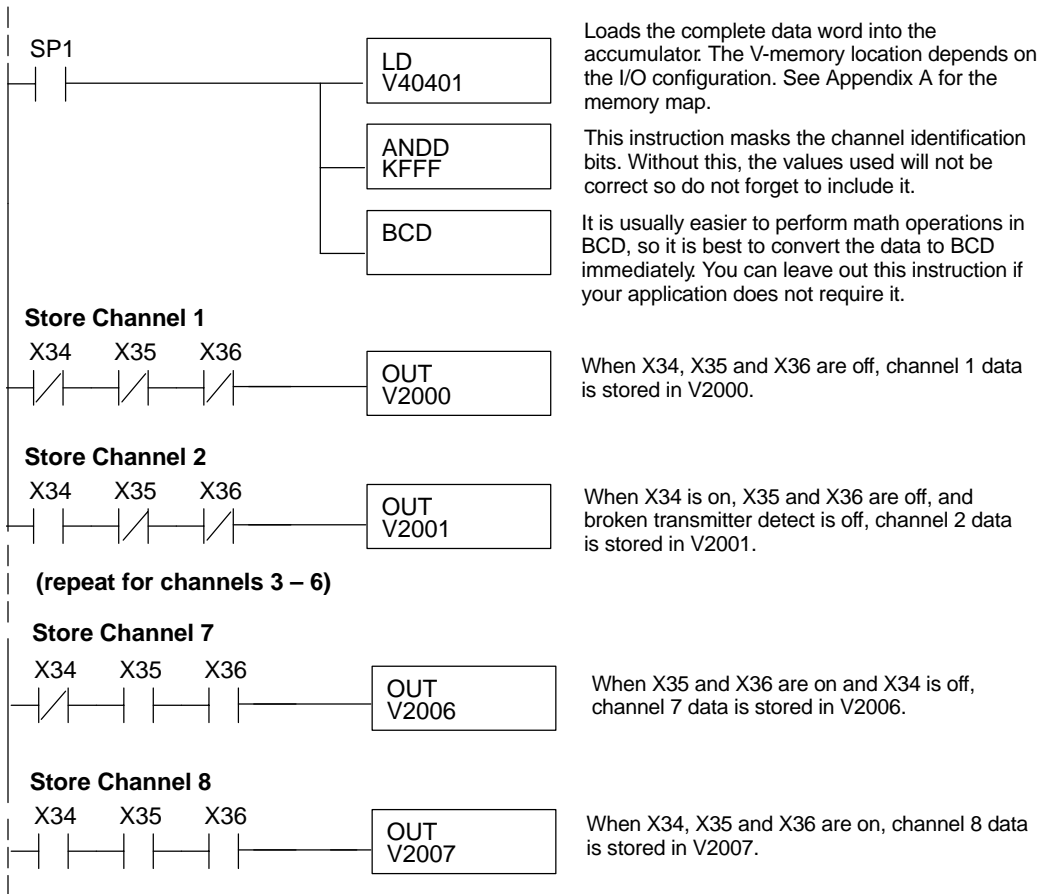

### Single Channel Selected

Since you do not have to determine which channel is selected, the single channel program is even simpler.

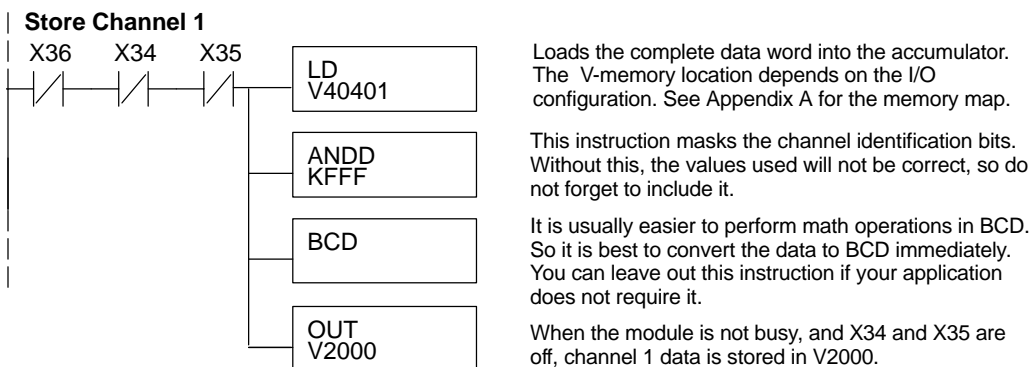

**Using Bipolar Ranges (Multiplexing)**

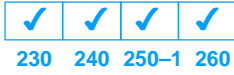

With bipolar ranges, you need some additional logic because you need to know if the value being returned represents a positive voltage or a negative voltage. For example, you may need to know the direction for a motor. Since the DL230 only reads one channel per scan, you can use the last input (X37 in the examples) to show the sign.

The following program shows how you can accomplish this. Since you always want to know when a value is negative, these rungs should be placed *before* any operations that use the data, such as math instructions, scaling operations, and so forth. Also, if you are using stage programming instructions, these rungs should be in a stage that is always active. Note, you only need the additional logic for those channels that are using bipolar input signals. The example shows two channels, but you can repeat these steps for all eight channels if necessary.

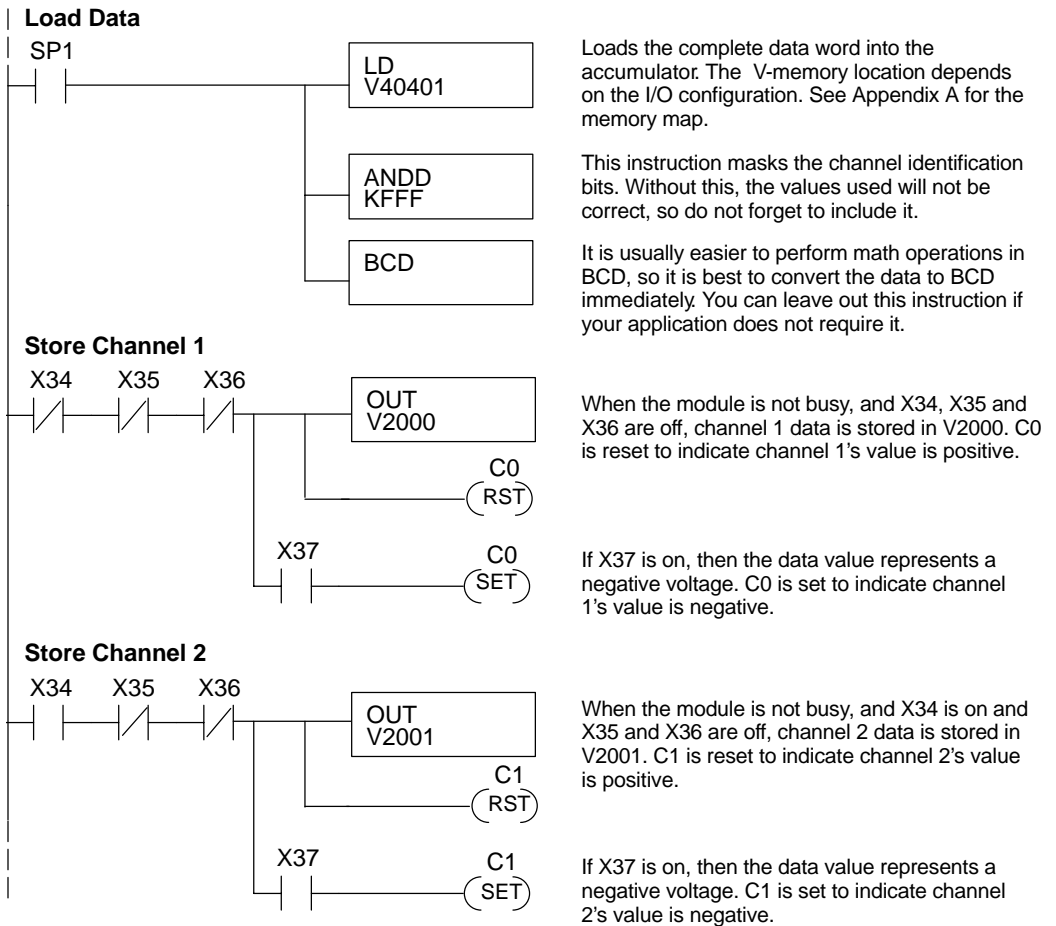

### Using 2's Complement (Multiplexing)

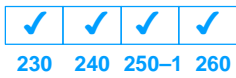

The 2's complement data format may be required to display negative values on some operator interface devices. It could also be used to simplify data averaging on bipolar signals. The example shows two channels, but you can repeat these steps for all eight channels if necessary.

#### Load data when module is not busy.

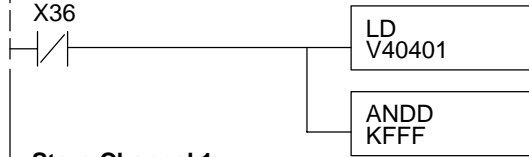

Loads the complete data word into the accumulator. The V-memory location depends on the I/O configuration. See Appendix A for the memory map.

This instruction masks the channel identification bits. Without this, the values used will not be correct, so do not forget to include it.

#### Store Channel 1

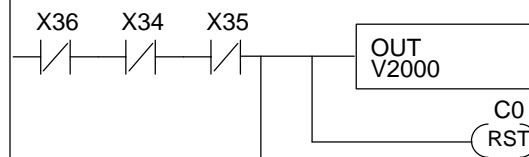

When the module is not busy, and X34, X35 and X36 are off, channel 1 data is stored in V2000. C0 is reset to indicate that channel 1's value is positive.



If X37 is on, then the data value represents a negative voltage. C0 is set to indicate that channel 1's value is negative.

Invert the bit pattern in the accumulator.

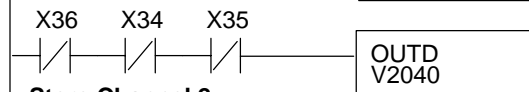
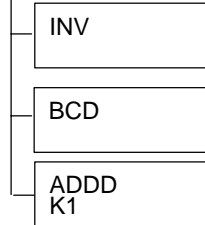

Channel 1 data is in double word starting at V2040.

#### Store Channel 2

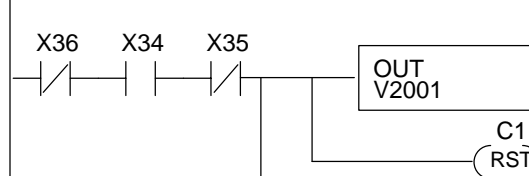

When the module is not busy, and X34 is on and X35 and X36 are off, channel 2 data is stored in V2001. C1 is reset to indicate that channel 2's value is positive.



If X37 is on, then the data value represents a negative voltage. C1 is set to indicate that channel 2's value is negative.

Invert the bit pattern in the accumulator.

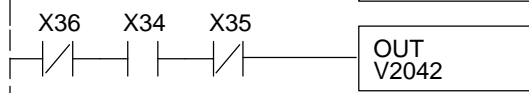
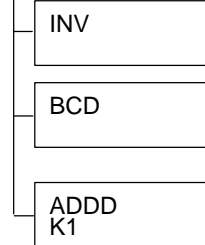

Channel 2 data is in double word starting at V2042.

**Analog Power Failure Detection**

The analog module has an on-board RISC-like microcontroller that can diagnose analog input circuit problems. You can easily create a simple ladder rung to detect these problems. This rung shows an input point that would be assigned if the module was used as shown in the previous examples. A different point would be used if the module was installed in a different I/O arrangement.

**Multiplexing method**

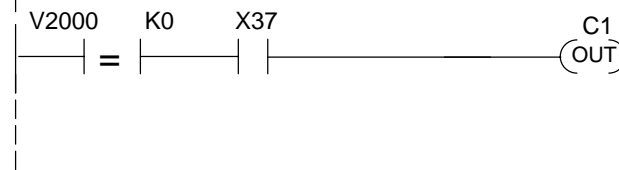

V-memory location V2000 holds channel 1 data. When a data value of zero is returned and input X37 is on, the analog channel is not operating properly.

**Pointer method**



V-memory location V2000 holds channel 1 data. When a data value of 8000 is returned, the analog channel is not operating properly.

**Scaling the Input Data**

Most applications usually require measurements in engineering units, which provide more meaningful data. This is accomplished by using the conversion formula shown.

You may have to make adjustments to the formula depending on the scale you choose for the engineering units.

$$\text{Units} = A \frac{H - L}{4095}$$

H = high limit of the engineering unit range

L = low limit of the engineering unit range

A = Analog value (0 – 4095)

For example, if you wanted to measure pressure (PSI) from 0.0 to 99.9 you would have to multiply the analog value by 10 in order to imply a decimal place when you view the value with the programming software or a handheld programmer. Notice how the calculations differ when you use the multiplier.

Analog Value of 2024, slightly less than half scale, should yield 49.4 PSI

Example without multiplier

$$\text{Units} = A \frac{H - L}{4095}$$

$$\text{Units} = 2024 \frac{100 - 0}{4095}$$

$$\text{Units} = 49$$

Handheld Display

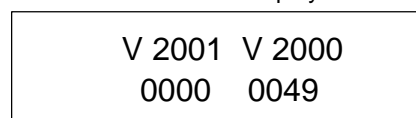

Example with multiplier

$$\text{Units} = 10 A \frac{H - L}{4095}$$

$$\text{Units} = 20240 \frac{100 - 0}{4095}$$

$$\text{Units} = 494$$

Handheld Display

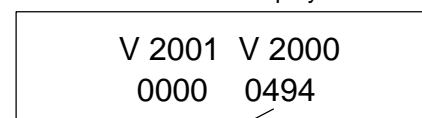

This value is more accurate.

The example below shows how you would write the program to perform the engineering unit conversion. This example assumes you have BCD data loaded into the appropriate V-memory locations using instructions that apply for the model of CPU you are using.

Note, this example uses SP1, which is always on. You could also use an X, C, etc. permissive contact.

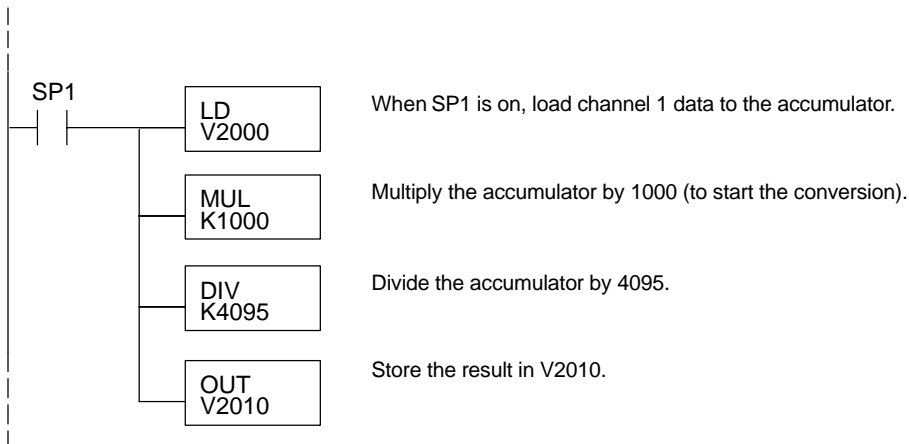

### Analog and Digital Value Conversions

Sometimes it is useful to be able to quickly convert between the signal levels and the digital values. This is especially helpful during machine startup or troubleshooting. Remember, this module *does not* operate like other versions of analog input modules that you may be familiar with. The bipolar ranges use 0–4095 for both positive and negative voltages. The sign bit allows this, which actually provides better resolution than those modules that do not offer a sign bit. The following table provides formulas to make this conversion easier.

Range	If you know the digital value ...	If you know the signal level ...
0 to 5V -5V to +5V	$A = \frac{5D}{4095}$	$D = \frac{4095}{5} (A)$
0 to 10V -10V to +10V	$A = \frac{10D}{4095}$	$D = \frac{4095}{10} (A)$

For example, if you are using the –10 to +10V range and you have measured the signal at 6V, use the following formula to determine the digital value that is stored in the V-memory location that contains the data.

$$D = \frac{4095}{10} (A)$$

$$D = \frac{4095}{10} (6V)$$

$$D = (409.5) (6)$$

$$D = 2457$$

**Filtering Input Noise (DL250-1, DL260 CPUs Only)**

×	×	✓	✓
230	240	250-1	260



Add the following logic to filter and smooth analog input noise in DL250-1 and DL260 CPUs. This is especially useful when using PID loops. Noise can be generated by the field device and/or induced by field wiring.

The analog value in BCD is first converted to a binary number because there is not a BCD-to-real conversion instruction. Memory location V1400 is the designated workspace in this example. The MULR instruction is the filter factor, which can be from 0.1 to 0.9. The example uses 0.2. A smaller filter factor increases filtering. You can use a higher precision value, but it is not generally needed. The filtered value is then converted back to binary and then to BCD. The filtered value is stored in location V1402 for use in your application or PID loop.

**NOTE:** Be careful not to do a multiple number conversion on a value. For example, if you are using the pointer method to get the analog value, it is in BCD and must be converted to binary. However, if you are using the conventional method of reading analog and are masking the first twelve bits, then it is already in binary and no conversion using the BIN instruction is needed.

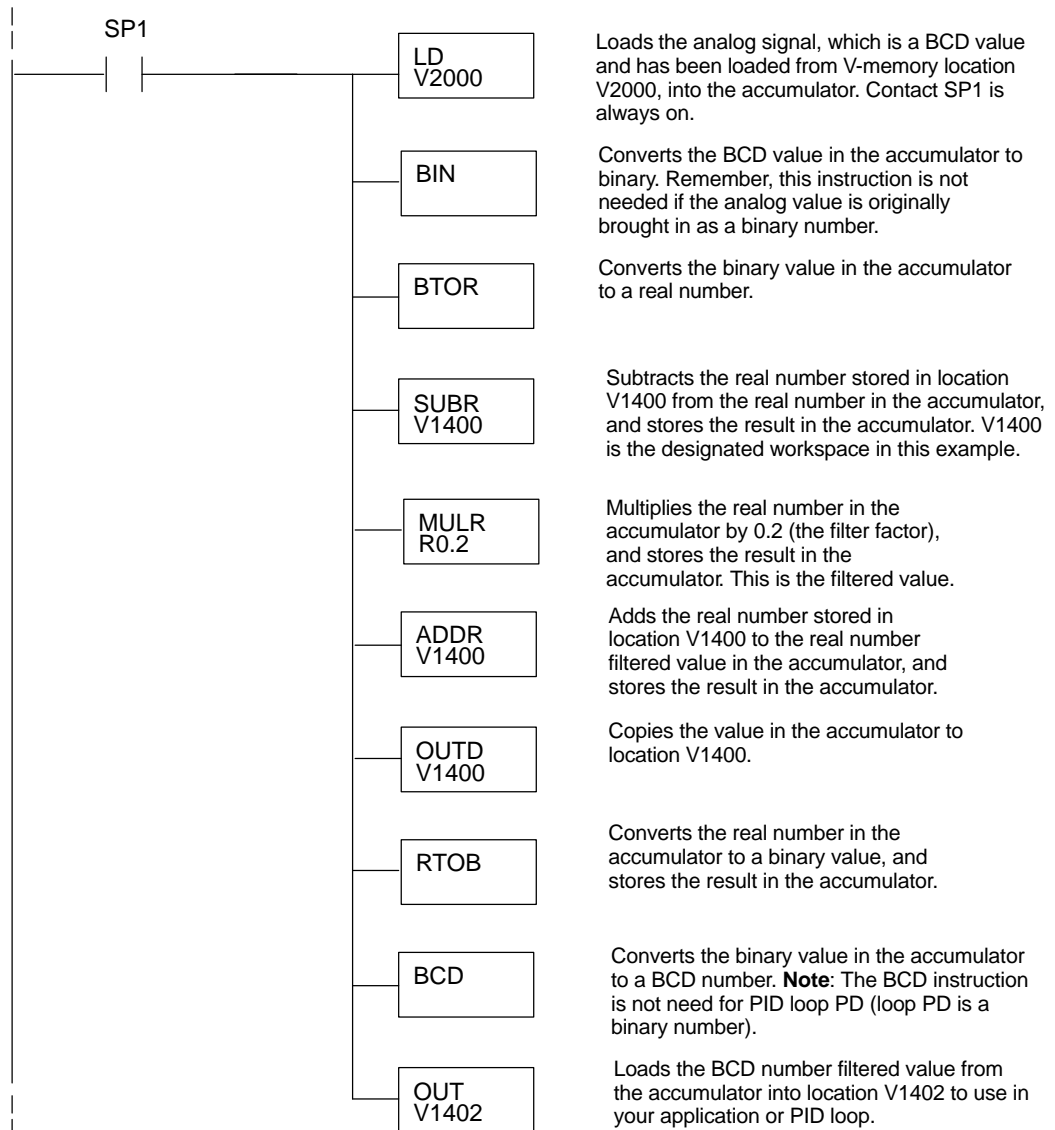

# F2-04RTD

## 4-Channel RTD Input

---

In This Chapter. . . .

- Module Specifications
  - Setting the Module Jumpers
  - Connecting the Field Wiring
  - Module Operation
  - Writing the Control Program
-

## Module Specifications

The F2-04RTD 4-Channel Resistive Temperature Detector Input Module provides several features and benefits:

- Provides four RTD input channels with 0.1°F resolution.
- Automatically converts type Pt100Ω, jPt100Ω, Pt1000Ω, Cu 25Ω, Cu10Ω signals into direct temperature readings. No extra scaling or complex conversion is required.
- Temperature data format is selectable between °F or °C, magnitude plus sign, or 2's complement.
- Precision lead wire resistance compensation by dual matched current sources and ratiometric measurements.
- Temperature calculation and linearization are based on data provided by the National Institute of Standards and Technology (NIST).
- Diagnostics features include detection of short circuits and input power disconnection.

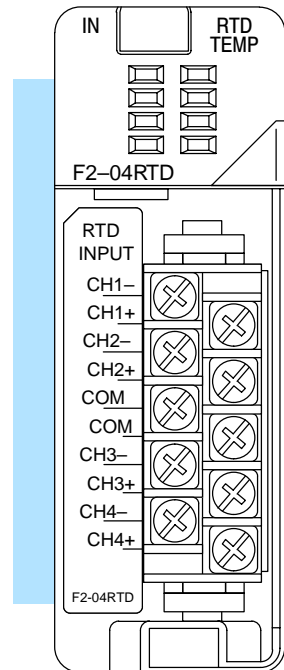

### Module Calibration

The module automatically re-calibrates every five seconds to remove any offset and gain errors. The F2-04RTD module requires no user calibration. However, if your process requires calibration, it is possible to correct the RTD tolerance using ladder logic. You can subtract or add a constant to the actual reading for that particular RTD.

### RTD Input Configuration Requirements

The F2-04RTD module requires 32 discrete input points from the CPU. The module can be installed in any slot of a DL205 system, including remote bases. The limiting factors on the number of analog modules used are:

- For local and local expansion systems, the available power budget and number of discrete I/O points.
- For remote I/O systems, the available power budget and number of remote I/O points.

Check the user manual for your particular CPU model for more information regarding the available power budget and number of local, local expansion or remote I/O points.



**NOTE:** DL230 CPUs with firmware release version 1.6 or later, DL240 CPUs with firmware release 2.5 or later, DL250 CPUs with firmware release version 1.06 or later are required for proper operation.

The following table provides the specifications for the F2-04RTD module. Review these specifications to make sure the module meets your application requirements.

### Input Specifications

Number of Channels	4, differential inputs
Input Ranges	Pt100      -200°C to 850°C (-328°F to 1562°F) Pt 1000    -200°C to 595°C (-328°F to 1103°F) jPt100     -38°C to 450°C (-36°F to 842°F) 10ΩCu.    -200°C to 260°C (-328°F to 500°F) 25ΩCu.    -200°C to 260°C (-328°F to 500°F)
Resolution	± 0.1 °C, ± 0.1 °F ( ± 3276.7)
Absolute Maximum Ratings	Fault protected input, ± 50 Vdc
Converter Type	Charge balancing, 24-bit
Sampling Rate	160 msec per channel
Linearity Error (End to End)	± 0.05 °C maximum, ± 0.01 °C typical
PLC Update Rate	4 Channels/Scan max. 240/250–1/260 CPU 1 Channel/Scan max. 230 CPU
Temperature Drift	5ppm per °C (maximum)
Maximum Inaccuracy	± 1°C
RTD Excitation Current	200 μA
Common Mode Range	0–5 VDC
Notch Filter	>100dB notches @ 50/60 Hz f <sub>-3dB</sub> = 13.1 Hz
Digital Input Points Required	32 (X) input points 15 binary data bits, 1 sign bit, 2 channel ID bits 4 fault bits
Power Budget Requirement	90 mA @ 5 VDC (from base)
Operating Temperature	0° to 60° C (32° to 140° F)
Storage Temperature	-20° to 70° C (-4° to 158° F)
Relative Humidity	5 to 95% (non-condensing)
Environmental air	No corrosive gases permitted
Vibration	MIL STD 810C 514.2
Shock	MIL STD 810C 516.2
Noise Immunity	NEMA ICS3–304

**Special Placement Requirements (DL230 and Remote I/O Bases)**

It is important to examine the configuration if you are using a DL230 CPU. As you can see in the section on writing the program, you use V-memory locations to send the analog data. If you place the module so that the input points do not start on a V-memory boundary, the instructions cannot access the data. This also applies when placing this module in a remote base using a D2-RSS in the CPU slot. See the table below.

**Correct!**

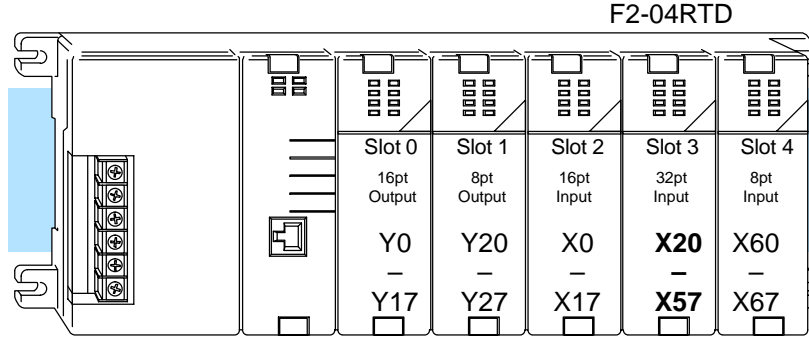

Data is correctly entered so input points start on a V-memory boundary address from the table below.

V40400				V40401 - V40402				V40403						
MSB	V40402			LSB	MSB	V40401			LSB	MSB	V40403			LSB
X	X	X	X	X	X	X	X	X	X	X	X	X	X	X
5	5	4	4	4	3	3	2	2	2	2	2	1	1	0
7	0	7	0	7	0	7	0	7	0	7	0	7	0	0

**Incorrect**

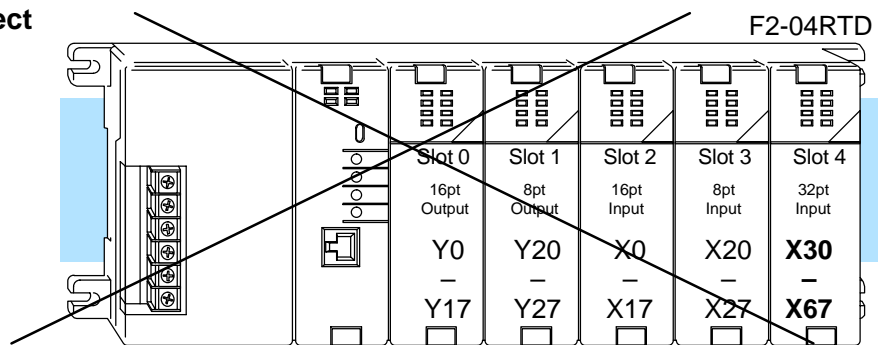

Data is split over three locations, so instructions cannot access data from a DL230.

V40403				V40402				V40401						
MSB	V40403			LSB	MSB	V40402			LSB	MSB	V40401			LSB
X	X	X	X	X	X	X	X	X	X	X	X	X	X	X
7	7	6	6	5	5	4	4	3	3	3	2	2	2	2
7	0	7	0	7	0	7	0	7	0	7	0	7	0	0

To use the V-memory references required for a DL230 CPU, the first input address assigned to the module must be one of the following X locations. The table also shows the V-memory addresses that correspond to these X locations.

<b>X</b>	X0	X20	X40	X60	X100	X120	X140	X160
<b>V</b>	V40400	V40401	V40402	V40403	V40404	V40405	V40406	V40407

## Setting the Module Jumpers

### Jumper Locations

Locate the bank of seven jumpers (J8) on the PC board. Notice that the description of each jumper is on the PC board. You can select the following options by installing or removing the jumpers:

- Number of channels: 1 thru 4.
- The input type: 10  $\Omega$  (ohms) or 25  $\Omega$  copper RTDs; jPt 100  $\Omega$ , Pt 100  $\Omega$  or Pt 1000  $\Omega$  RTDs
- Temperature conversion: 2's complement or magnitude plus sign format in Fahrenheit or Celsius.

To prevent losing a jumper when it is removed, store it near its original location by sliding one of its sockets over a single pin.

### Selecting the Number of Channels

The two jumpers labeled **CH+1** and **CH+2** are used to select the number of channels that will be used. The factory default setting is four-channel operation (both jumpers installed). Any unused channels are not processed. For example, if you select channels 1 thru 3, channel 4 will be inactive. The table shows how to arrange the jumpers to select the number of channels.

X = jumper installed, empty space = jumper removed

Number of Channels	Jumper	
	CH+1	CH+2
1		
2	X	
3		X
4	X	X

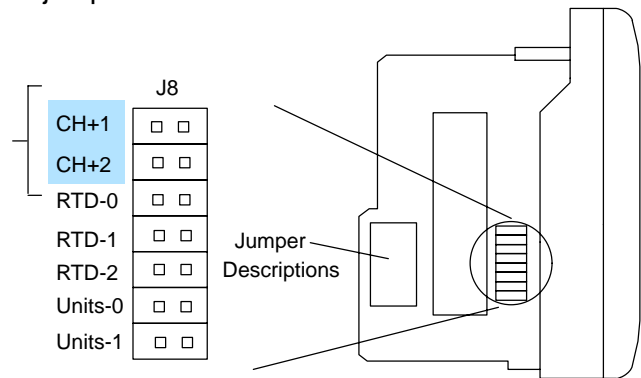

### Setting Input Type

The jumpers labeled **RTD-0**, **RTD-1**, and **RTD-2** are used to select the type of RTD. The module can be used with many types of RTDs. All channels of the module must be the same RTD type.

The default setting from the factory is Pt100  $\Omega$  (RTD-2 comes with the jumper removed). This selects the DIN 43760 European type RTD. European curve type RTDs are calibrated to DIN 43760, BS1905, or IEC751 specifications which is  $.00385 \Omega / \Omega / ^\circ \text{C}$  ( $100^\circ \text{C} = 138.5\Omega$ ).

The jPt100  $\Omega$  type is used for the American curve ( $.00392 \Omega / \Omega / ^\circ \text{C}$ ), platinum 100  $\Omega$  RTDs. The 10  $\Omega$  and 25  $\Omega$  RTD settings are used with copper RTDs.

The table shows how to arrange the jumpers to set the input type.

X = jumper installed, empty space = jumper removed

RTD Inputs	Jumper Pins		
	RTD-0	RTD-1	RTD-2
Cu 10 $\Omega$			
Cu 25 $\Omega$	X		
jPt100 $\Omega$		X	
Pt100 $\Omega$	X	X	
Pt1000 $\Omega$			X

### Selecting the Conversion Units

Use the last two jumpers, **Units-0** and **Unit-1**, to set the conversion unit. The options are magnitude + sign or 2's complement in Fahrenheit or Celsius. The module comes from the factory with both jumpers installed for magnitude + sign conversion in Fahrenheit.

All RTD types are converted into a direct temperature reading in either Fahrenheit or Celsius. The data contains one implied decimal place. For example, a value in V-memory of 1002 would be 100.2°C or °F.

Negative temperatures can be represented in either 2's complement or magnitude plus sign form. If the temperature is negative, the most significant bit in the V-memory location is set (X17).

The 2's complement data format may be required to correctly display bipolar data on some operator interfaces. This data format could also be used to simplify averaging a bipolar signal. To view this data format in **DirectSoft32**, select Signed Decimal.

The table shows how to arrange the jumpers.

X = jumper installed, empty space = jumper removed.

Jumper	Temperature Conversion Units			
	Magnitude + Sign		2's Complement	
	°F	°C	°F	°C
<b>Units-0</b>	X		X	
<b>Units-1</b>	X	X		

## Connecting the Field Wiring

### Wiring Guidelines

Your company may have guidelines for wiring and cable installation. If so, you should check those before you begin the installation. Here are some general things to consider:

- Use the shortest wiring route whenever possible.
- Use shielded wiring and ground the shield at the transmitter source. *Do not* ground the shield at both the module and the source.
- Do not run the signal wiring next to large motors, high current switches, or transformers. This may cause noise problems.
- Route the wiring through an approved cable housing to minimize the risk of accidental damage. Check local and national codes to choose the correct method for your application.

### RTD – Resistance Temperature Detector

Use shielded RTDs whenever possible to minimize noise on the input signal. Ground the shield wire at one end only. Connect the shield wire to the COM terminal.

#### Lead Configuration for RTD Sensors

The suggested three-lead configuration shown below provides one lead to the CH+ terminal, one lead to the CH- terminal, and one lead to the common terminal. Compensation circuitry nulls out the lead length for accurate temperature measurements.

Some sensors have four leads. When making connections, do not connect the second lead to the CH+ input; leave that lead unconnected.

Do not use configurations having only one lead connected to each input. There is no compensation and temperature readings will be inaccurate.

This module has low RTD excitation current, worst-case dissipation is only .016 mW.

Wiring Connections For Typical RTD Sensor

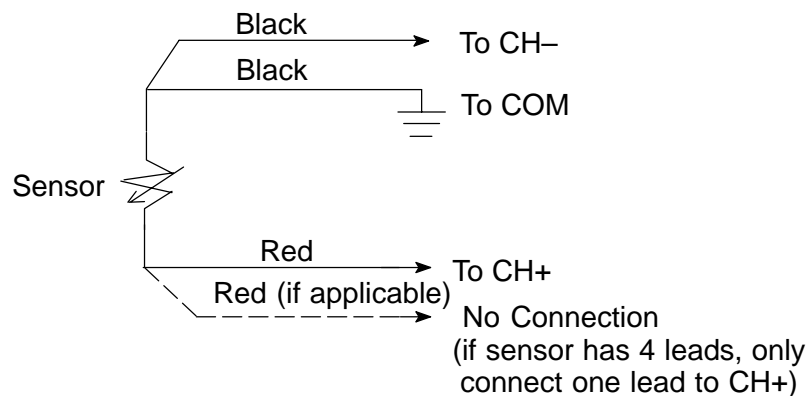

### Ambient Variations in Temperature

The F2-04RTD module has been designed to operate within the ambient temperature range of 0°C to 60°C.

Precision analog measurement with no long term temperature drift is assured by a chopper stabilized programmable gain amplifier, ratiometric referencing, and automatic offset and gain calibration.

**Wiring Diagram**

The F2-04RTD module has a removable connector to make wiring easier. Simply squeeze the top and bottom retaining clips and gently pull the connector from the module.

**Wiring Diagram**

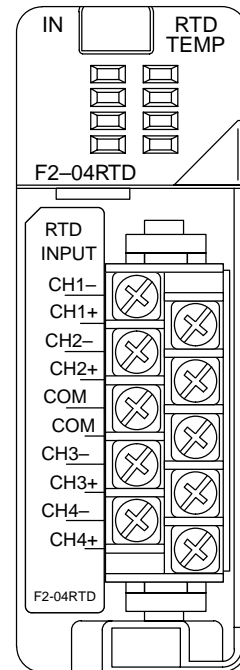
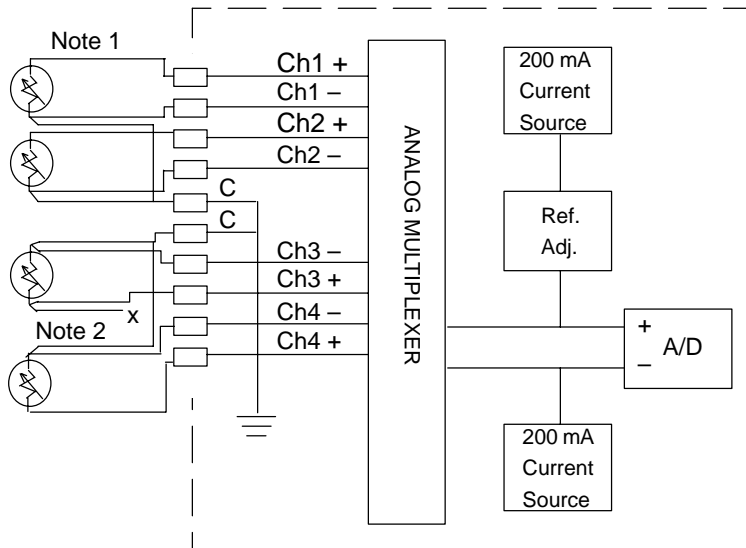

**Notes:**

1. The three wires connecting the RTD to the module must be the same type and length. Do not use the shield or drain wire for the third connection.
2. If the RTD sensor has four wires, the plus (+) sense wire should be left UNCONNECTED as shown.

## Module Operation

Before you begin writing the control program, it is important to take a few minutes to understand how the module processes and represents the analog signals.

### Channel Scanning Sequence for a DL230 CPU (Multiplexing)

The F2-04RTD module can supply different amounts of data per scan, depending on the type of CPU you are using. The DL230 can obtain one channel of data per CPU scan. Since there are four channels, it can take up to four scans to get data for all channels. Once all channels have been scanned the process starts over with channel 1. Unused channels are not processed, so if you select only two channels, each channel will be updated every other scan. The multiplexing method can also be used for the DL240/250-1/260 CPUs.

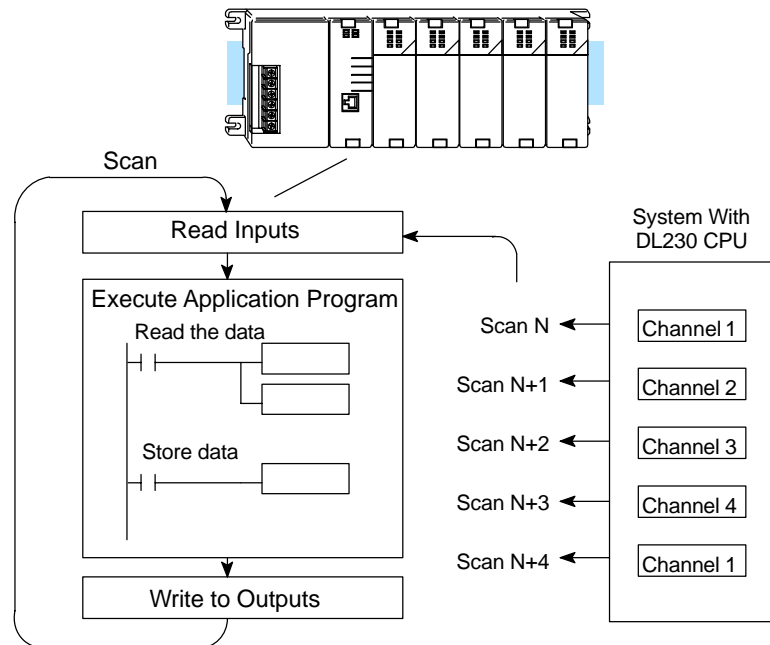

### Channel Scanning Sequence for a DL240, DL250-1 or DL260 CPU (Pointer Method)

If you are using a DL240, DL250-1 or DL260 CPU, you can obtain all four channels of input data in one scan. This is because the DL240/250-1/260 CPUs support special V-memory locations that are used to manage the data transfer. This is discussed in more detail in the section on Writing the Control Program.

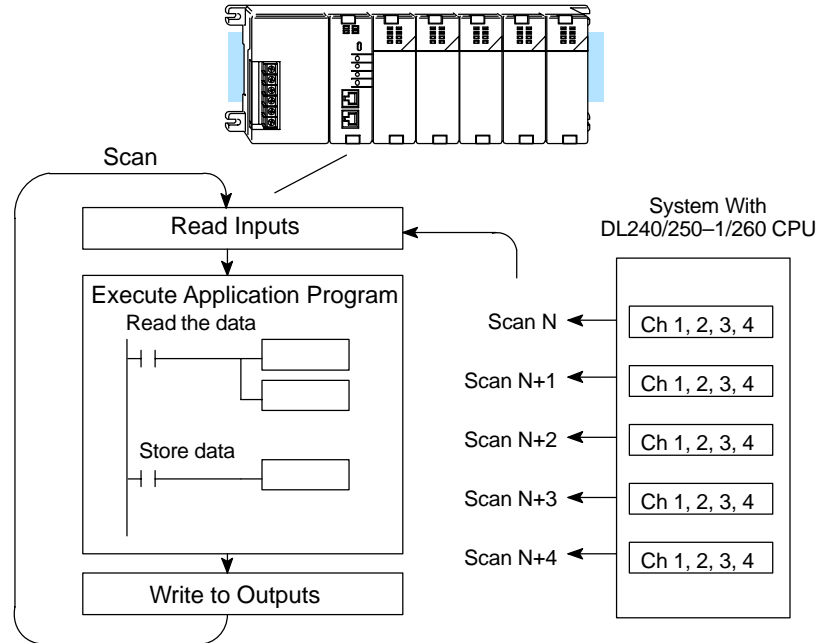

### Analog Module Updates

Even though the channel updates to the CPU are synchronous with the CPU scan, the module asynchronously monitors the analog transmitter signal and converts the signal to a 16-bit binary representation. This enables the module to continuously provide accurate measurements without slowing down the discrete control logic in the RLL program.

The time required to sense the temperature and copy the value to V-memory is 160 milliseconds minimum to 640 milliseconds plus 1 scan time maximum (number of channels  $\times$  160 msec + 1 scan time).

# Writing the Control Program

## Reading Values: Pointer Method and Multiplexing

There are two methods of reading values:

- The pointer method
- Multiplexing

You *must* use the multiplexing method when using a DL230 CPU. You must also use the multiplexing method with remote I/O modules (the pointer method will not work). You can use either method when using DL240, DL250-1 and DL260 CPUs, but for ease of programming it is strongly recommended that you use the pointer method.

## Pointer Method

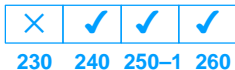

The CPU has special V-memory locations assigned to each base slot that greatly simplify the programming requirements. These V-memory locations:

- specify the number of channels to scan.
- specify the storage locations.

The example program shows how to setup these locations. Place this rung anywhere in the ladder program, or in the initial stage if you are using stage programming instructions. This is all that is required to read the data into V-memory locations. Once the data is in V-memory, you can perform math on the data, compare the data against preset values, and so forth. V2000 is used in the example, but you can use any user V-memory location. In the examples, the module is installed in slot 2. You should use the V-memory locations used in your application. The pointer method automatically converts values to BCD.



**NOTE:** DL240 CPUs with firmware release version 2.5 or later and DL250 CPUs with firmware release version 1.06 or later support this method. Use the DL230 multiplexing example if your firmware revision is earlier (verify that the addresses in the CPU are zero).

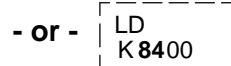
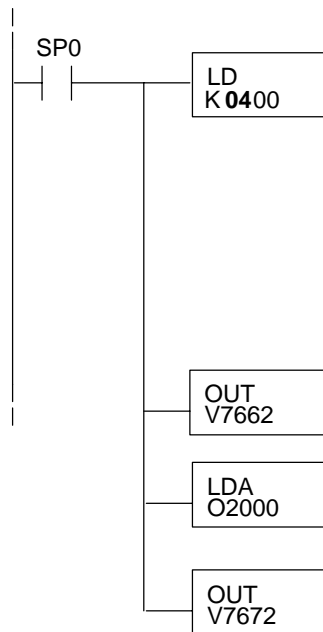

Loads a constant that specifies the number of channels to scan and the data format. The upper byte, most significant nibble (MSN) selects the data format (0=BCD, 8=Binary), the LSN selects the number of channels (1, 2, 3, or 4).

The binary format is used for displaying data on some operator interfaces. The DL230/240 CPUs do not support binary math functions, whereas the DL250 does.

Special V-memory location assigned to slot 2 that contains the number of channels to scan.

This loads an octal value for the first V-memory location that will be used to store the incoming data. For example, the O2000 entered here would designate the following addresses:  
Ch1 – V2000, V2001, Ch 2 – V2002, V2003, Ch 3 – V2004, V2005, Ch 4 – V2006, V2007.

The octal address (O2000) is stored here. V7672 is assigned to slot 2 and acts as a pointer, which means the CPU will use the octal value in this location to determine exactly where to store the incoming data.

The tables below show the special V-memory locations used by the DL240, DL250–1 and DL260 for the CPU base and local expansion base I/O slots. Slot 0 (zero) is the module next to the CPU or D2–CM module. Slot 1 is the module two places from the CPU or D2–CM, and so on. Remember, the CPU only examines the pointer values at these locations after a mode transition. Also, if you use the DL230 (multiplexing) method, verify that these addresses in the CPU are zero.

The Table below applies to the DL240, DL250–1 and DL260 CPU base.

<b>CPU Base: Analog Input Module Slot-Dependent V-memory Locations</b>								
Slot	0	1	2	3	4	5	6	7
No. of Channels	V7660	V7661	V7662	V7663	V7664	V7665	V7666	V7667
Storage Pointer	V7670	V7671	V7672	V7673	V7674	V7675	V7676	V7677

The Table below applies to the DL250–1 or DL260 expansion base 1.

<b>Expansion Base D2–CM #1: Analog Input Module Slot-Dependent V-memory Locations</b>								
Slot	0	1	2	3	4	5	6	7
No. of Channels	V36000	V36001	V36002	V36003	V36004	V36005	V36006	V36007
Storage Pointer	V36010	V36011	V36012	V36013	V36014	V36015	V36016	V36017

The Table below applies to the DL250–1 or DL260 expansion base 2.

<b>Expansion Base D2–CM #2: Analog Input Module Slot-Dependent V-memory Locations</b>								
Slot	0	1	2	3	4	5	6	7
No. of Channels	V36100	V36101	V36102	V36103	V36104	V36105	V36106	V36107
Storage Pointer	V36110	V36111	V36112	V36113	V36114	V36115	V36116	V36117

The Table below applies to the DL260 CPU expansion base 3.

<b>Expansion Base D2–CM #3: Analog Input Module Slot-Dependent V-memory Locations</b>								
Slot	0	1	2	3	4	5	6	7
No. of Channels	V36200	V36201	V36202	V36203	V36204	V36205	V36206	V36207
Storage Pointer	V36210	V36211	V36212	V36213	V36214	V36215	V36216	V36217

The Table below applies to the DL260 CPU expansion base 4.

<b>Expansion Base D2–CM #4: Analog Input Module Slot-Dependent V-memory Locations</b>								
Slot	0	1	2	3	4	5	6	7
No. of Channels	V36300	V36301	V36302	V36303	V36304	V36305	V36306	V36307
Storage Pointer	V36310	V36311	V36312	V36313	V36314	V36315	V36316	V36317

### Negative Temperature Readings with Magnitude Plus Sign (Pointer Method)

✘	✔	✔	✔
230	240	250-1	260



With bipolar ranges, you need some additional logic to determine whether the value being returned represents a positive voltage or a negative voltage. For example, you may need to know the direction for a motor. There is a simple solution:

- If you are using bipolar ranges and you get a value greater than or equal to  $8000_H$ , the value is negative.
- If you get a value less than or equal to  $7FFF_H$ , the value is positive.

The sign bit is the most significant bit, which combines  $8000_H$  to the data value. If the value is greater than or equal to  $8000_H$ , you only have to mask the most significant bit and the active channel bits to determine the actual data value.

**NOTE:** DL240 CPUs with firmware release version 2.5 or later and DL250 CPUs with firmware release version 1.06 or later support this method. Use the DL230 multiplexing example if your firmware revision is earlier.

The following two programs show how you can accomplish this. The first example uses magnitude plus sign (binary) and the second example uses magnitude plus sign (BCD).

Since you always want to know when a value is negative, these rungs should be placed *before* any other operations that use the data, such as math instructions, scaling operations, and so forth. Also, if you are using stage programming instructions, these rungs should be in a stage that is always active. Note: you only need this logic for each channel that is using bipolar input signals. The following examples only show two channels.

### Magnitude Plus Sign (Binary)

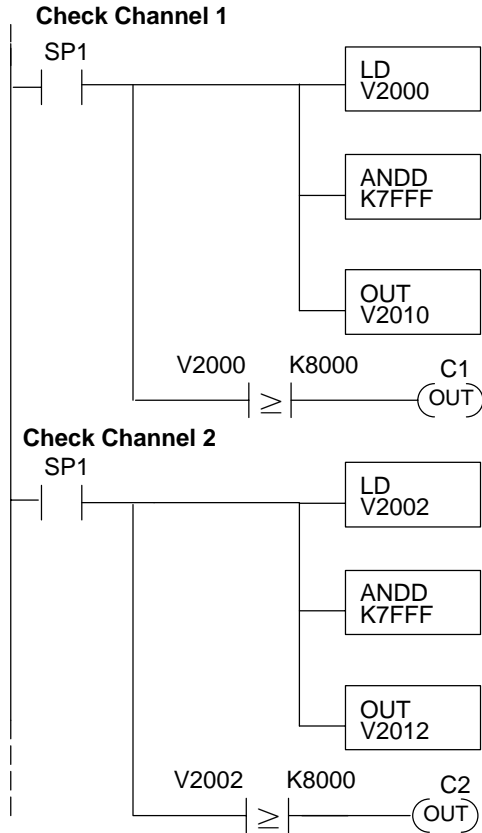

Load channel 1 data from V-memory into the accumulator. Contact SP1 is always on.

This instruction masks the sign bit of the binary data, if it is set. Without this step, negative values will not be correct so do not forget to include it.

Put the actual signal value in V2010. Now you can use the data normally.

Channel 1 data is negative when C1 is on (a value of -1.0 reads as 8010, -2.0 is 8020, etc.).

Load channel 2 from V-memory into the accumulator. Contact SP1 is always on.

This instruction masks the sign bit of the binary data, if it is set. Without this step, negative values will not be correct so do not forget to include it.

Put the actual signal value in V2012. Now you can use the data normally.

Channel 2 data is negative when C2 is on (a value of -1.0 reads as 8010, -2.0 is 8020, etc.).

### Magnitude Plus Sign (BCD)

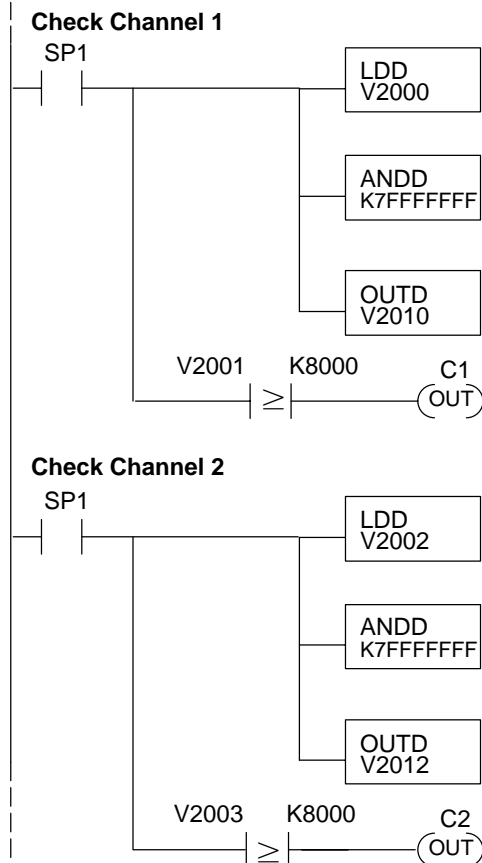

Load channel 1 data from V-memory into the accumulator. Remember, the data can be negative. Contact SP1 is always on.

This instruction masks the sign bit of the BCD data, if it is set. Without this step, negative values will not be correct so do not forget to include it.

Put the actual signal value in V2010. Now you can use the data normally.

Channel 1 data is negative when C1 is on (a value of -1.0 reads as 8000 0010, -2.0 is 8000 0020, etc.).

Load channel 2 from V-memory into the accumulator. Remember, the data can be negative. Contact SP1 is always on.

This instruction masks the sign bit of the BCD data, if it is set. Without this step, negative values will not be correct so do not forget to include it.

Put the actual signal value in V2012. Now you can use the data normally.

Channel 2 data is negative when C2 is on (a value of -1.0 reads as 8000 0010, -2.0 is 8000 0020, etc.).

**Negative Temperatures 2's Complement (Binary / Pointer Method)**

X	✓	✓	✓
230	240	250-1	260

You can use the 2's complement mode for negative temperature display purposes, while at the same time using the magnitude plus sign of the temperature in your control program. The *DirectSOFT32* element Signed Decimal is used to display negative numbers in 2's complement form. To find the absolute value of a negative number in 2's complement, invert the number and add 1 as shown in the following example:

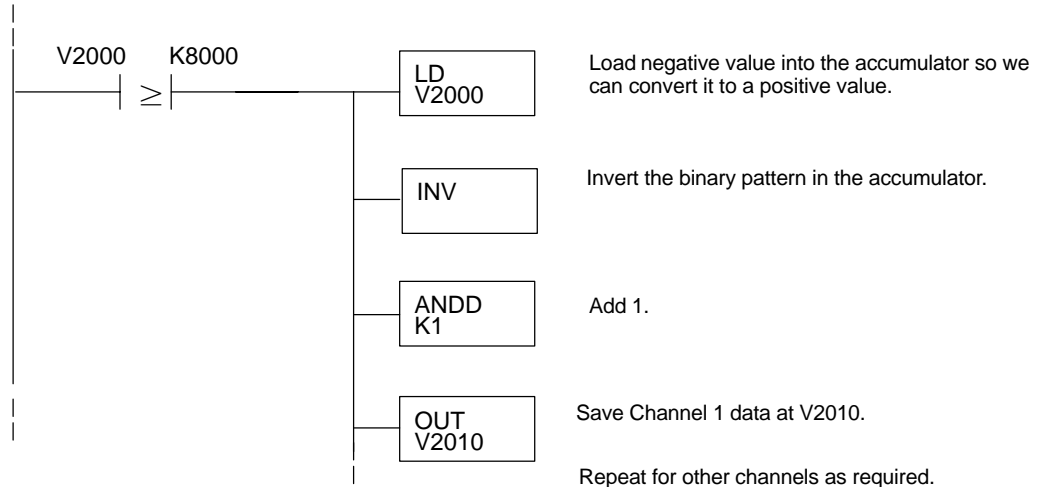

**Understanding the Input Assignments (Multiplexing Ladder Only)**

✓	✓	✓	✓
230	240	250-1	260

You may recall that this module appears to the CPU as a 32-point discrete input module. You can use these points to obtain:

- An indication of which channel is active
- The digital representation of the analog signal
- Module diagnostic information

Since all input points are automatically mapped into V-memory, it is very easy to determine the location of the data word that will be assigned to the module.

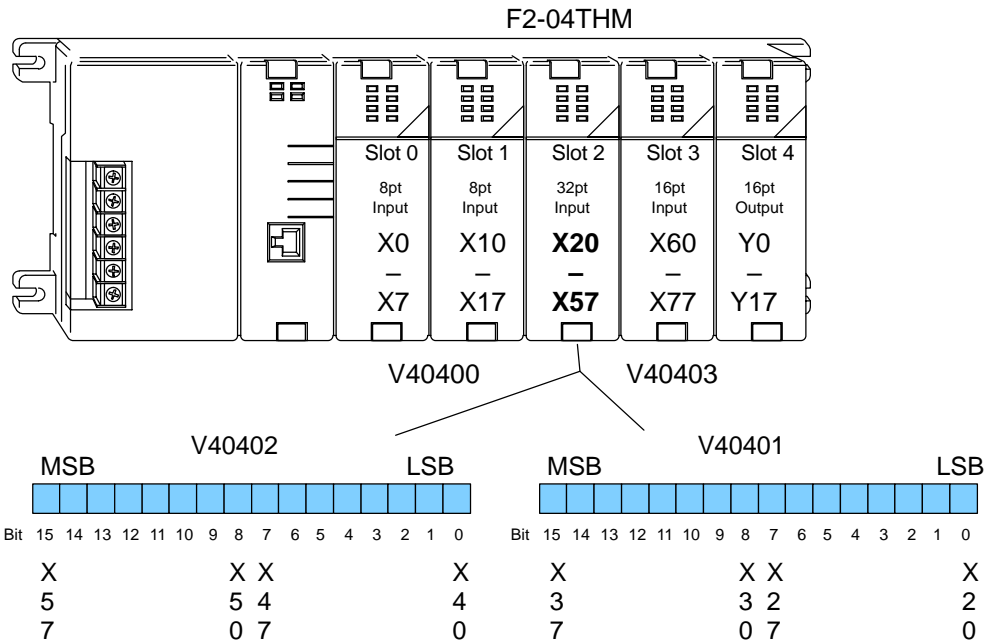

Remember, when using DL230 CPUs input points must start on a V-memory boundary. To use the V-memory references required for a DL230 CPU, the *first* input address assigned to the module must be one of the following X locations. The table also shows the V-memory addresses that correspond to these X locations.

<b>X</b>	X0	X20	X40	X60	X100	X120	X140	X160
<b>V</b>	V40400	V40401	V40402	V40403	V40404	V40405	V40406	V40407

### Analog Data Bits

The first 16 bits represent the analog data in binary format.

Bit	Value	Bit	Value
0	1	8	256
1	2	9	512
2	4	10	1024
3	8	11	2048
4	16	12	4096
5	32	13	8192
6	64	14	16384
7	128	15	32768

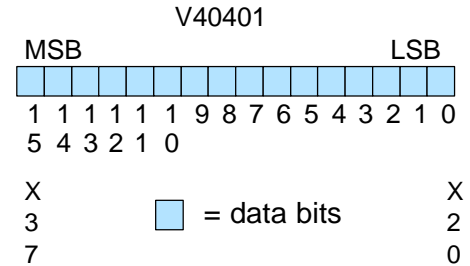

### Active Channel Bits

The active channel bits represent the multiplexed channel selections in binary format.

Bit 1	Bit 0	Channel
0	0	1
0	1	2
1	0	3
1	1	4

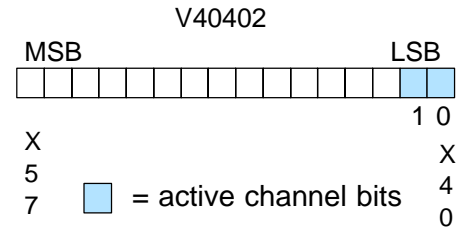

### Broken Transmitter Bits (Pointer and Multiplexing Ladder Methods)

The broken transmitter bits are on when the corresponding RTD is open.

Bit	Channel
8	1
9	2
10	3
11	4

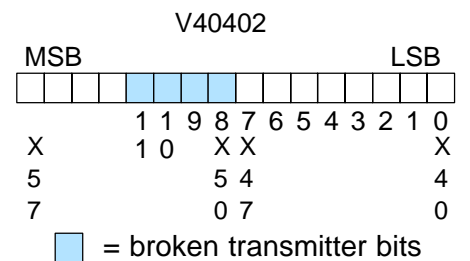

**Reading  
Magnitude Plus  
Sign Values  
(Multiplexing)**

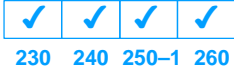

The DL230 CPU *does not* have the special V-memory locations that allow you to automatically enable the data transfer. Since all channels are multiplexed into a single data word, the control program must be setup to determine which channel is being read. Since the module appears as X input points to the CPU, it is very easy to use the active channel status bits to determine which channel is being monitored.

**NOTE:** DL230 CPUs with firmware release version 1.6 or later required for multiplexing ladder.

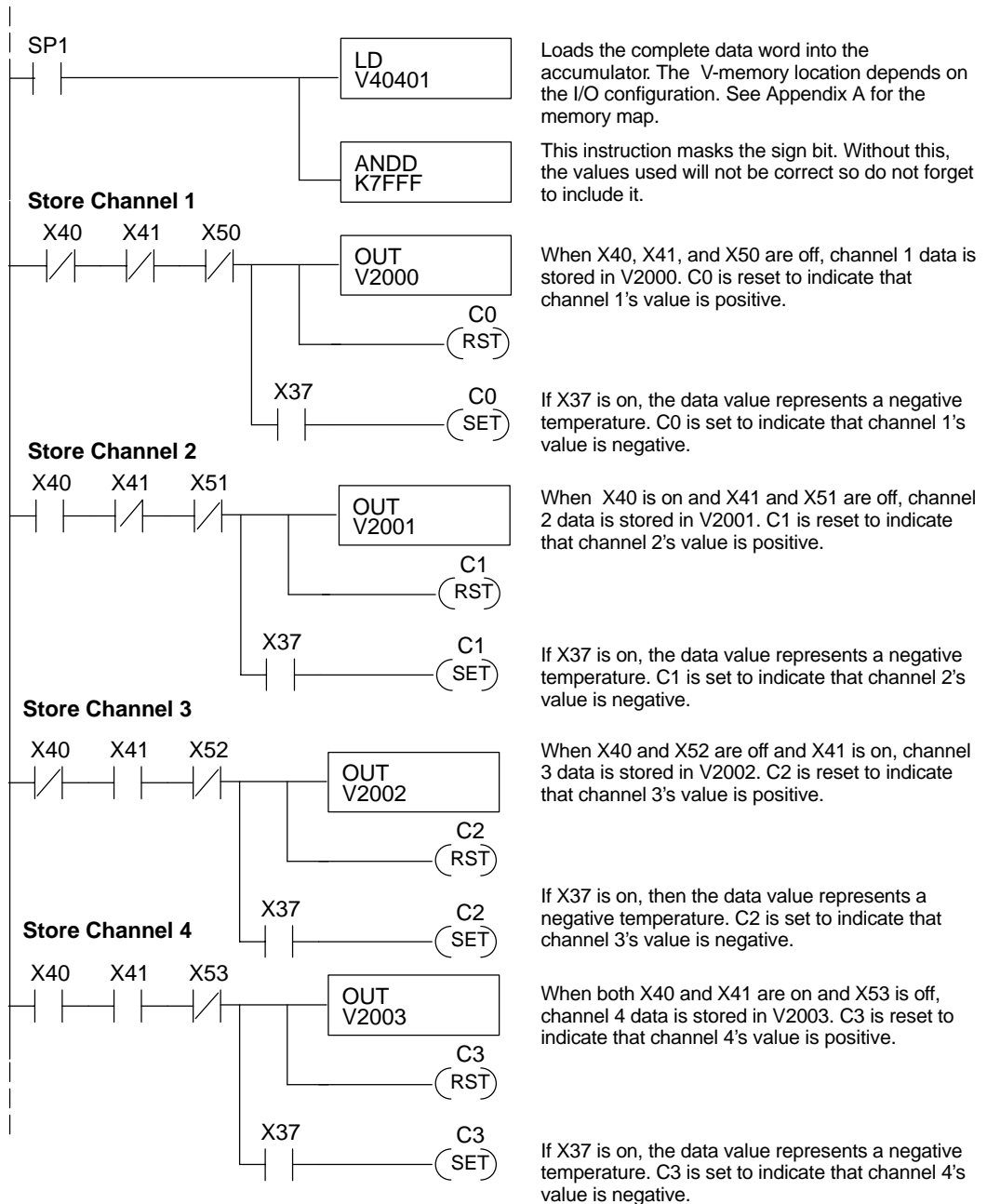

### Reading 2's Complement Values (Multiplexing)

✓	✓	✓	✓
230	240	250-1	260

The DL230 CPU *does not* have the special V-memory locations that allow you to automatically enable the data transfer. Since all channels are multiplexed into a single data word, the control program must be setup to determine which channel is being read. Since the module appears as X input points to the CPU, it is very easy to use the active channel status bits to determine which channel is being monitored. The 2's complement data format may be required to correctly display bipolar data on some operator interfaces. This data format could also be used to simplify averaging a bipolar signal. To view this data format in **DirectSOFT32**, select Signed Decimal.

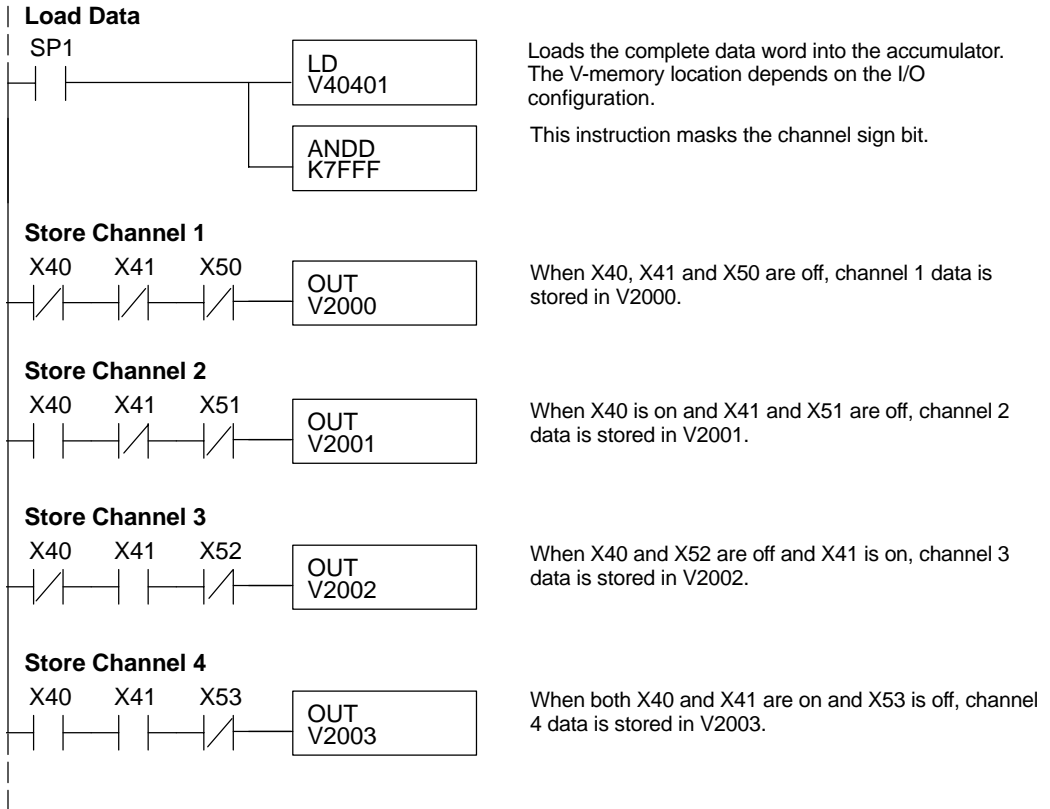

### Scaling the Input Data

No scaling of the input temperature is required. The readings directly reflect the actual temperatures. For example: a reading of 8482 is 848.2 °C, a reading of 16386 is -0.2°C. (magnitude plus sign) and a reading of 32770 is -0.2°C (2's complement).

### Filtering Input Noise (DL250-1, DL260 CPUs Only)

×	×	✓	✓
230	240	250-1	260

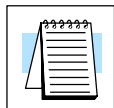

Add the following logic to filter and smooth analog input noise in DL250-1 and DL260 CPUs. This is especially useful when using PID loops. Noise can be generated by the field device and/or induced by field wiring.

The analog value in BCD is first converted to a binary number because there is not a BCD-to-real conversion instruction. Memory location V1400 is the designated workspace in this example. The MULR instruction is the filter factor, which can be from 0.1 to 0.9. The example uses 0.2. A smaller filter factor increases filtering. You can use a higher precision value, but it is not generally needed. The filtered value is then converted back to binary and then to BCD. The filtered value is stored in location V1402 for use in your application or PID loop.

**NOTE:** Be careful not to do a multiple number conversion on a value. For example, if you are using the pointer method to get the analog value, it is in BCD and must be converted to binary. However, if you are using the conventional method of reading analog and are masking the first fifteen bits, then it is already in binary and no conversion using the BIN instruction is needed. Also, if you are using the conventional method, change the LLD V2000 instruction to LD V2000.

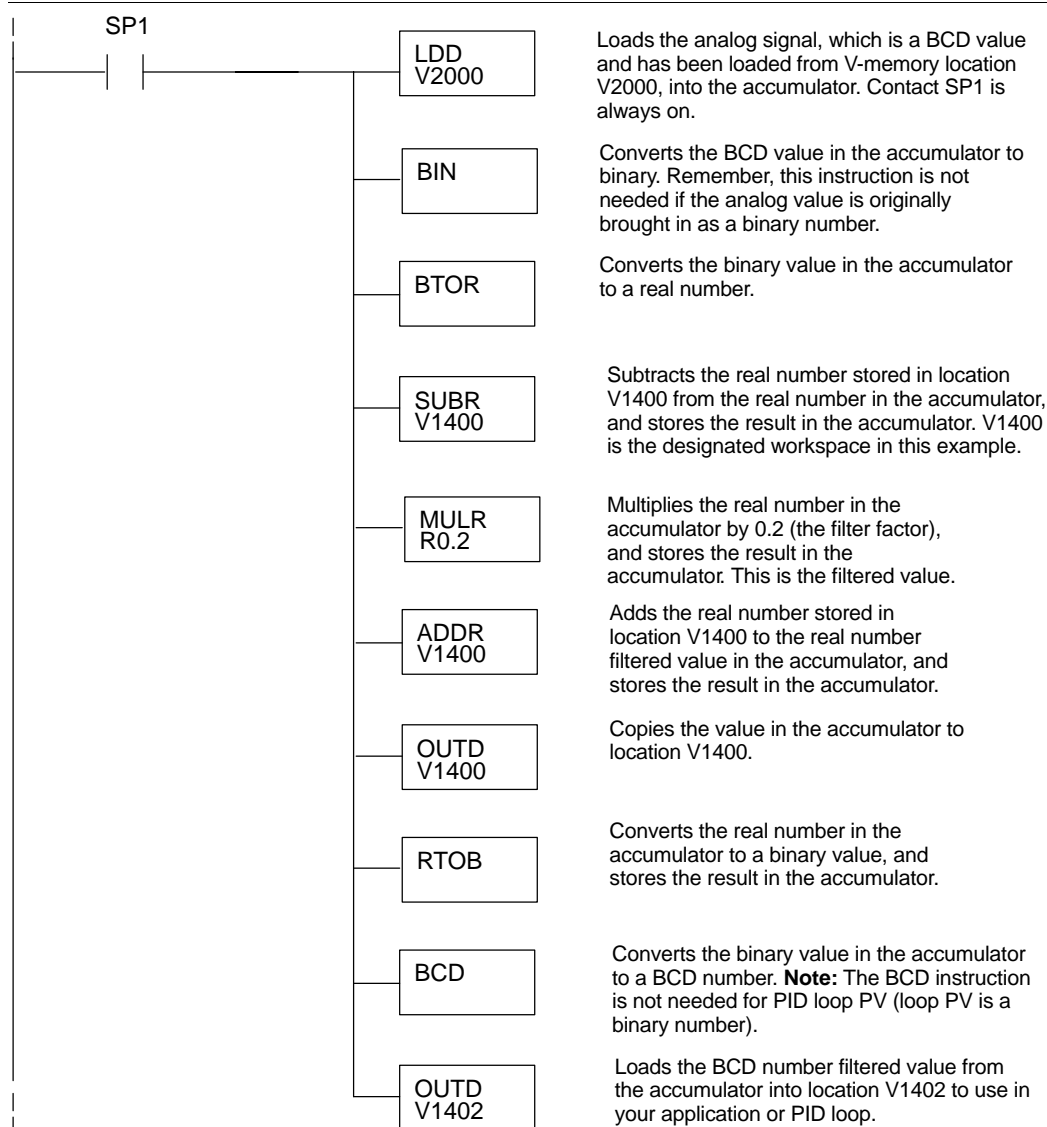

# F2-04THM

## 4-Channel

# Thermocouple Input

---

In This Chapter. . . .

- Module Specifications
  - Setting The Module Jumpers
  - Connecting the Field Wiring
  - Module Operation
  - Writing the Control Program
-

## Module Specifications

The F2-04THM 4-Channel Thermocouple Input Module provides several features and benefits.

- Four thermocouple input channels with 16-bit voltage resolution or 0.1 °C/°F temperature resolution.
- Automatically converts type E, J, K, R, S, T, B, N, or C thermocouple signals into direct temperature readings. No extra scaling or complex conversion is required.
- Temperature data can be expressed in °F or °C.
- Module can be configured as  $\pm 5V$ ,  $\pm 156mV$ , 0–5V or 0–156 mV and will convert volts and millivolt signal levels into 16-bit digital (0–65535) values.
- Signal processing features include automatic cold junction compensation, thermocouple linearization, and digital filtering.
- The temperature calculation and linearization are based on data provided by the National Institute of Standards and Technology (NIST).
- Diagnostic features include detection of thermocouple burnout or disconnection.

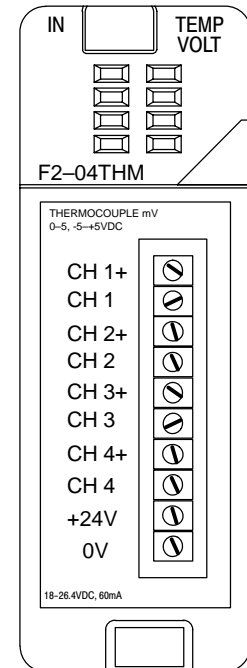

The following tables provide the specifications for the F2-04THM Analog Input Module. Review these specifications to make sure the module meets your application requirements.

### General Specifications

Number of Channels	4, differential
Common Mode Range	$\pm 5VDC$
Common Mode Rejection	90dB min. @ DC, 150dB min. @ 50/60 Hz.
Input Impedance	1M $\Omega$
Absolute Maximum Ratings	Fault-protected inputs to $\pm 50 VDC$
Accuracy vs. Temperature	$\pm 5 ppm/^{\circ}C$ maximum full scale calibration (including maximum offset change)
PLC Update Rate	4 channels per scan max. DL240/250–1/260 CPU 1 channel per scan max. DL230 CPU
Digital Inputs Input Points Required	16 binary data bits, 2 channel ID bits, 4 diagnostic bits 32 point (X) input module
External Power Supply	60 mA maximum, 18 to 26.4 VDC
Power Budget Requirement	110 mA maximum, 5 VDC (supplied by base)
Operating Temperature	0 to 60° C (32 to 140° F)
Storage Temperature	–20 to 70° C (–4 to 158° F)
Relative Humidity	5 to 95% (non-condensing)
Environmental air	No corrosive gases permitted
Vibration	MIL STD 810C 514.2
Shock	MIL STD 810C 516.2
Noise Immunity	NEMA ICS3–304

One count in the specification table is equal to one least significant bit of the analog data value (1 in 65535).

**Thermocouple Specifications**

Input Ranges	Type J -190 to 760°C -310 to 1400°F Type E -210 to 1000°C -346 to 1832°F Type K -150 to 1372°C -238 to 2502°F Type R 65 to 1768°C 149 to 3214°F Type S 65 to 1768°C 149 to 3214°F Type T -230 to 400°C -382 to 752°F Type B 529 to 1820°C 984 to 3308°F Type N -70 to 1300°C -94 to 2372°F Type C 65 to 2320°C 149 to 4208°F
Display Resolution	± 0.1°C / ± 0.1°F
Cold Junction Compensation	Automatic
Warm-Up Time	30 min. typically ± 1°C repeatability
Linearity Error (End to End)	± .05°C maximum, ± .01°C typical
Maximum Inaccuracy	± 3°C (excluding thermocouple error)

**Voltage Specifications**

Voltage Ranges	Voltage: 0-5V, ±5V, 0-156.25mV, ± 156.25mVDC
Resolution	16 bit (1 in 65535)
Full Scale Calibration Error (Offset Error Included)	± 13 counts typical, ± 33 maximum
Offset Calibration Error	± 1 count maximum, @ 0V input
Linearity Error (End to End)	± 1 count maximum
Maximum Inaccuracy	± .02% @ 25°C (77°F)

**Module Calibration**

The F2-04THM module requires no calibration. The module automatically calibrates every five seconds, which removes offset and gain errors. For each thermocouple type, the temperature calculation and linearization performed by the microprocessor is accurate to within .01 °C.

**Thermocouple Input Configuration Requirements**

The F2-04THM module requires 32 discrete input points from the CPU. The module can be installed in any slot of a DL205 system. The limitations on the number of analog modules are:

- For local and local expansion systems, the available power budget and number of discrete I/O points.
- For remote I/O systems, the available power budget and number of remote I/O points.

Check the user manual for your particular model of CPU and I/O base for more information regarding power budget and number of local, local expansion or remote I/O points.

**Special Placement Requirements (DL230 and Remote I/O Bases)**

It is important to examine the configuration if you are using a DL230 CPU. As you can see in the section on writing the program, you use V-memory locations to send the analog data. If you place the module so that the input points do not start on a V-memory boundary, the instructions cannot access the data. This also applies when placing this module in a remote base using a D2-RSSS in the CPU slot.

**Correct!**

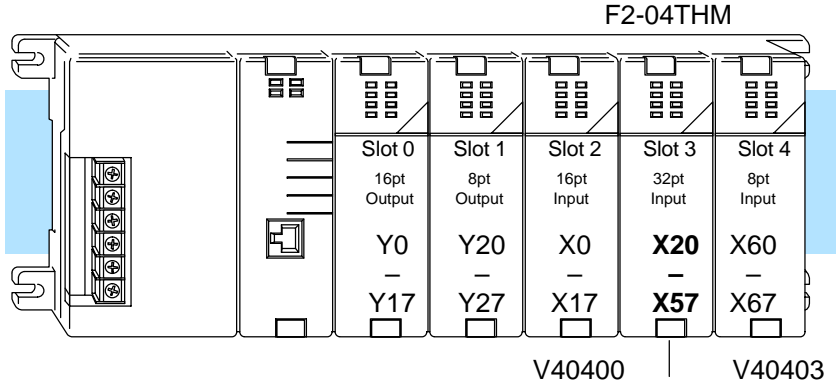

Data is correctly entered so input points start on a V-memory boundary address from the table below.

V40402			V40401		
MSB		LSB	MSB		LSB
X	X X	X	X	X X	X
5	5 4	4	3	3 2	2
7	0 7	0	7	0 7	0

**Incorrect**

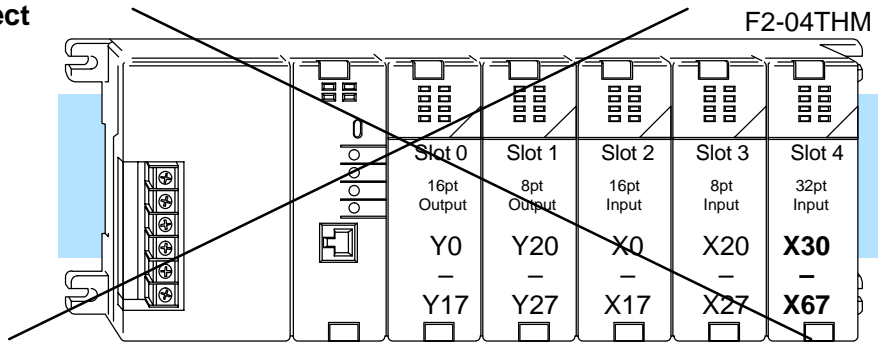

Data is split over three locations, so instructions cannot access data from a DL230.

V40403			V40402			V40401		
MSB		LSB	MSB		LSB	MSB		LSB
X	X X	X	X	X X	X	X	X X	X
7	7 6	6	5	5 4	4	3	3 2	2
7	0 7	0	7	0 7	0	7	0 7	0

To use the V-memory references required for a DL230 CPU, the *first* input address assigned to the module must be one of the following X locations. The table also shows the V-memory addresses that correspond to these X locations.

<b>X</b>	X0	X20	X40	X60	X100	X120	X140	X160
<b>V</b>	V40400	V40401	V40402	V40403	V40404	V40405	V40406	V40407

F2-04THM 4-Ch. Thermocouple

## Setting the Module Jumpers

### Jumper Locations

Use the figure below to locate the single jumper (J9) and bank of eight jumpers (J7) on the PC board. Notice that the description of each jumper is just to the right of the jumpers on the PC board. To prevent losing a jumper when it is removed, store it in its original location by sliding one of its sockets over a single pin. You can select the following options by installing or removing the appropriate jumpers:

- Number of channels
- Input type
- Conversion units
- Calibrate enable

### Calibrate Enable

See the figure below to locate the “Calibrate Enable” jumper J9. The jumper comes from the factory in the “jumper removed” setting (the jumper is installed over only one of the two pins). Installing this jumper disables the thermocouple active burn-out detection circuitry, which enables you to attach a thermocouple calibrator to the module.

To make sure that the output of the thermocouple calibrator is within the 5V common mode voltage range of the module, connect the negative side of the differential voltage input channel to the 0V terminal, then connect the thermocouple calibrator to the differential inputs (for example, Ch 3+ and Ch 3).

For the voltage input ranges, this jumper is inactive and can be installed or removed with no effect on voltage input.

### Selecting the Number of Channels

The top two jumpers labeled **CH+1** and **CH+2** determine the number of channels that will be used. The table shows how to set the jumpers for channels 1 thru 4. The module comes with both jumpers installed for four channel operation. For example, to select channels 1 thru 3, leave the CH+2 jumper installed and remove the CH+1 jumper. Any unused channels are not processed. For example, if you only select channels 1 thru 3, channel 4 will not be active.

X = jumper installed,  
blank space = jumper removed

Number of Channels	Jumper	
	CH+1	CH+2
1		
2	X	
3		X
4	X	X

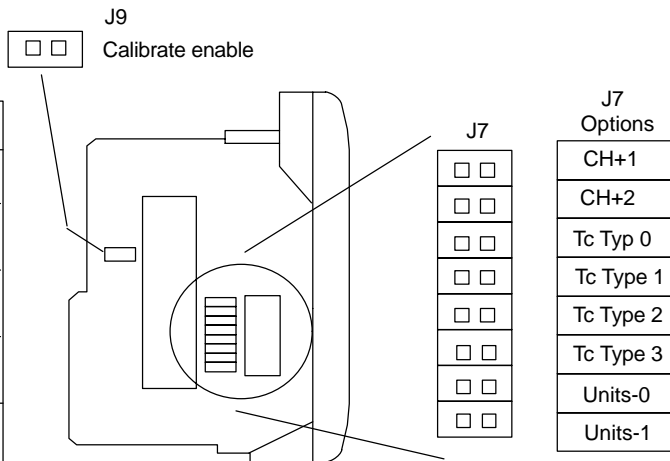

**Setting Input Type**

The next four jumpers (**Tc Type 0, Tc Type 1, Tc Type 2, Tc Type 3**) must be set to match the type of thermocouple being used or the input voltage level. The module can be used with many types of thermocouples. Use the table to determine your settings.

The module comes from the factory with all four jumpers installed for use with a J type thermocouple. For example, to use an S type thermocouple, remove the jumper labeled Tc Type 2. All channels of the module must be the same thermocouple type or voltage range.

X = Jumper installed, and blank space = jumper removed.

Thermocouple / Voltage Inputs	Jumper			
	Tc Type 0	Tc Type 1	Tc Type 2	Tc Type 3
J	X	X	X	X
K		X	X	X
E	X		X	X
R			X	X
S	X	X		X
T		X		X
B	X			X
N				X
C	X	X	X	
0-5V.		X	X	
±5V.	X		X	
0-156mV.			X	
±156mV.	X	X		

**Selecting the Conversion Units**

Use the last two jumpers, **Units-0** and **Units-1**, to set the conversion unit used for either thermocouples or voltage inputs. The options are magnitude plus sign or 2's complement, plus Fahrenheit or Celsius for thermocouples. See the next two sections for jumper settings when using thermocouples or if using voltage inputs.

**Thermocouple Conversion Units**

All thermocouple types are converted into a direct temperature reading in either Fahrenheit or Celsius. The data contains one implied decimal place. For example, a value in V-memory of 1002 would be 100.2°C or °F.

For thermocouple ranges which include negative temperatures (J,E,K,T,N), the display resolution is from -3276.7 to +3276.7. For positive-only thermocouple ranges (R,S,B,C), the display resolution is 0 to 6553.5.

Negative temperatures can be represented in either 2's complement or magnitude plus sign form. If the temperature is negative, the most significant bit in the V-memory location is set (X17).

The 2's complement data format may be required to correctly display bipolar data on some operator interfaces. This data format could also be used to simplify averaging a bipolar signal. To view this data format in **DirectSoft32**, select Signed Decimal.

For unipolar thermocouple ranges (R,S,B,C), it does not matter if magnitude plus sign or 2's complement is selected.

Use the table to select settings. The module comes with both jumpers installed for magnitude plus sign conversion in Fahrenheit. For example, remove the Units-0 jumper and leave the Units-1 jumper installed for magnitude plus sign conversion in Celsius.

X = Jumper installed, and blank space = jumper removed.

Jumper	Temperature Conversion Units			
	Magnitude Plus Sign		2's Complement	
	°F	°C	°F	°C
<b>Units-0</b>	X		X	
<b>Units-1</b>	X	X		

The bipolar voltage input ranges,  $\pm 5V$  or  $\pm 156mV$  (see previous page for  $\pm 5V$  and  $\pm 156mV$  settings), may be converted to a 15-bit magnitude plus sign or a 16-bit 2's complement value.

Use the table to select settings. The module comes with both jumpers installed for magnitude plus sign conversion. Remove the Units-1 jumper and leave the Units-0 jumper installed for 2's complement conversion.

X = Jumper installed, and blank space = jumper removed.

Jumper Pins	Voltage Conversion Units	
	Magnitude Plus Sign	2's Complement
<b>Units-0</b>	X	X
<b>Units-1</b>	X	

### Voltage Conversion Units

## Connecting the Field Wiring

### Wiring Guidelines

Your company may have guidelines for wiring and cable installation. If so, you should check those before you begin the installation. Here are some general things to consider:

- Use the shortest wiring route whenever possible.
- Use shielded wiring and ground the shield at the transmitter source. *Do not* ground the shield at both the module and the source.
- Do not run the signal wiring next to large motors, high current switches, or transformers. This may cause noise problems.
- Route the wiring through an approved cable housing to minimize the risk of accidental damage. Check local and national codes to choose the correct method for your application.

### User Power Supply Requirements

You may use the same or separate power source for the 0–5V or 0–156mV transmitter voltage supply. The DL205 bases have built-in 24 VDC power supplies that provide up to 300mA of current. You may use this instead of a separate supply if you are using only a couple of analog modules and voltage transmitters.

It is desirable in some situations to power the transmitters separately in a location remote from the PLC. This will work as long as the transmitter supply meets the voltage and current requirements and the transmitter's minus (–) side and the module supply's minus (–) side are connected together.



---

**WARNING:** If you are using the 24 VDC base power supply, make sure you calculate the power budget. Exceeding the power budget can cause unpredictable system operation that can lead to a risk of personal injury or damage to equipment.

---

The DL205 base has a switching type power supply. As a result of switching noise, you may notice some instability in the analog input data if you use the base power supply. If this is unacceptable, you should try one of the following:

1. Use a separate linear power supply.
2. Connect the 24VDC common to the frame ground, which is the screw terminal marked “G” on the base.

Unused temperature inputs should be shorted together and connected to common.

**Thermocouples**

Use shielded thermocouples whenever possible to minimize the presence of noise on the thermocouple wire. Ground the shield wire at one end only. For grounded thermocouples, connect the shield at the sensor end. For ungrounded thermocouples, connect the shield to the 0V (common) terminal.

**Grounded Thermocouple Assembly**

A grounded thermocouple provides better response time than an ungrounded thermocouple because the tip of the thermocouple junction is in direct contact with the protective case.

**Ungrounded Thermocouple Assembly**

An ungrounded thermocouple is electrically isolated from the protective case. If the case is electrically grounded it provides a low-impedance path for electrical noise to travel. The ungrounded thermocouple provides a more stable and accurate measurement in a noisy environment.

**Exposed Grounded Thermocouple**

The thermocouple does not have a protective case and is directly connected to a device with a higher potential. Grounding the thermocouple assures that the thermocouple remains within the common mode specifications. Because a thermocouple is essentially a wire, it provides a low-impedance path for electrical noise. The noise filter has a response of >100dB @ 50/60 Hz.

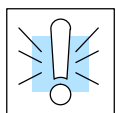

**WARNING:** A thermocouple can become shorted to a high voltage potential. Because common terminals are internally connected together, whatever voltage potential exists on one thermocouple will exist on the other channels.

**Ambient Variations in Temperature**

The F2-04THM module has been designed to operate within the ambient temperature range of 0°C to 60°C.

The cold junction compensation is calibrated to operate in a still-air environment. If the module is used in an application that has forced convection cooling, an error of 2–3°C may be introduced. To compensate for this you can use ladder logic to correct the values.

When configuring the system design it is best to locate any heat-producing devices above and away from the PLC chassis because the heat will affect the temperature readings. For example, heat introduced at one end of the terminal block can cause a channel-to-channel variation.

When exposing the F2-04THM module to abrupt ambient temperature changes it will take several minutes for the cold junction compensation and terminal block to stabilize. Errors introduced by abrupt ambient temperature changes will be less than 4°C.

**Wiring Diagram**

Use the following diagrams to connect the field wiring.

### Thermocouple Input Wiring Diagram

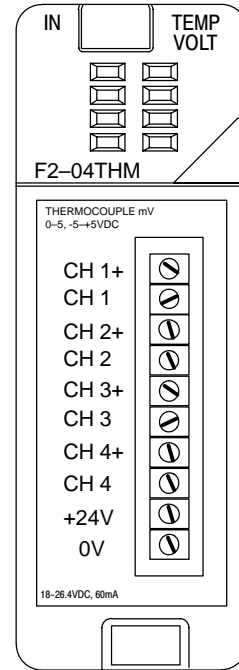
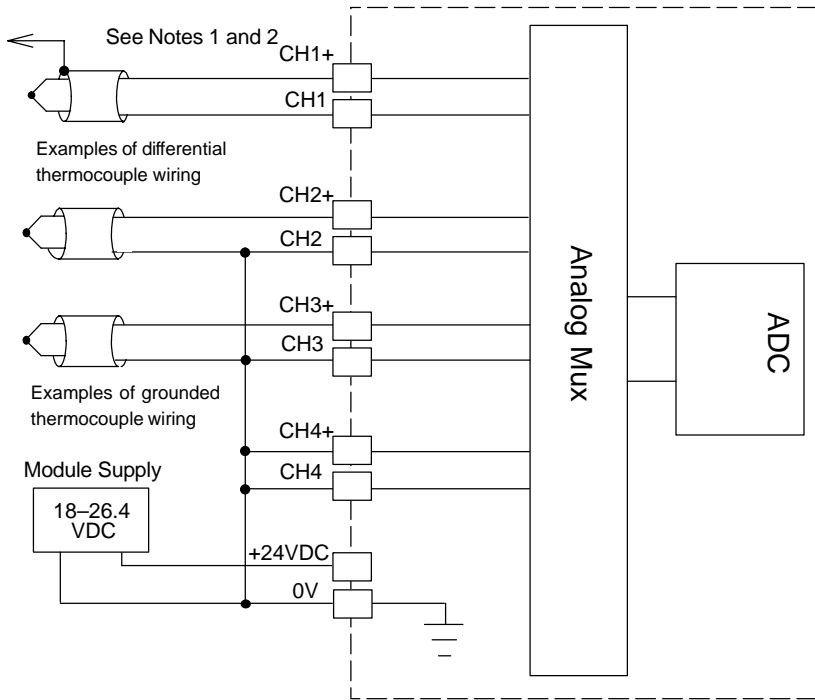

Note 1: Terminate shields at the respective signal source.

Note 2: Connect unused channels to a common terminal (0V, CH4+, CH4).

### Voltage Input Wiring Diagram

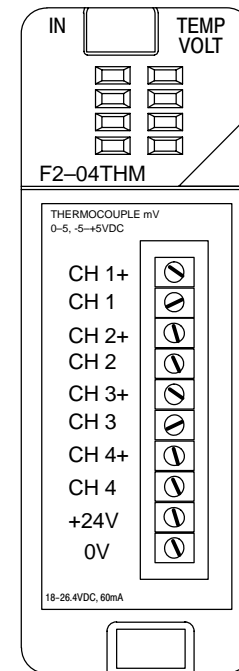
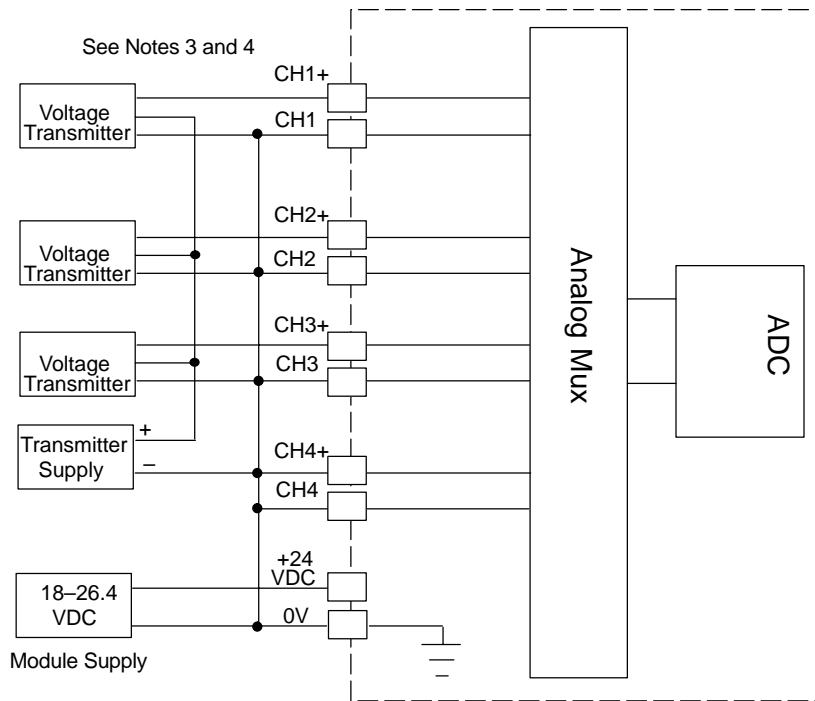

Note 3: Connect unused channels to a common terminal (0V, CH4+, CH4).

Note 4: When using 0-156mV and 5V ranges, connect (-) or (0) volts terminals (CH1, CH2, CH3, CH4, CH4+) to 0V to ensure common mode range acceptance.

## Module Operation

### Channel Scanning Sequence for a DL230 CPU (Multiplexing)

Before you begin writing the control program, it is important to take a few minutes to understand how the module processes and represents the analog signals.

The F2-04THM module can supply different amounts of data per scan, depending on the type of CPU you are using. The DL230 can obtain one channel of data per CPU scan. Since there are four channels, it can take up to four scans to get data for all channels. Once all channels have been scanned the process starts over with channel 1. Unused channels are not processed, so if you select only two channels, then each channel will be updated every other scan. The multiplexing method can also be used for the DL240/250-1/260 CPUs.

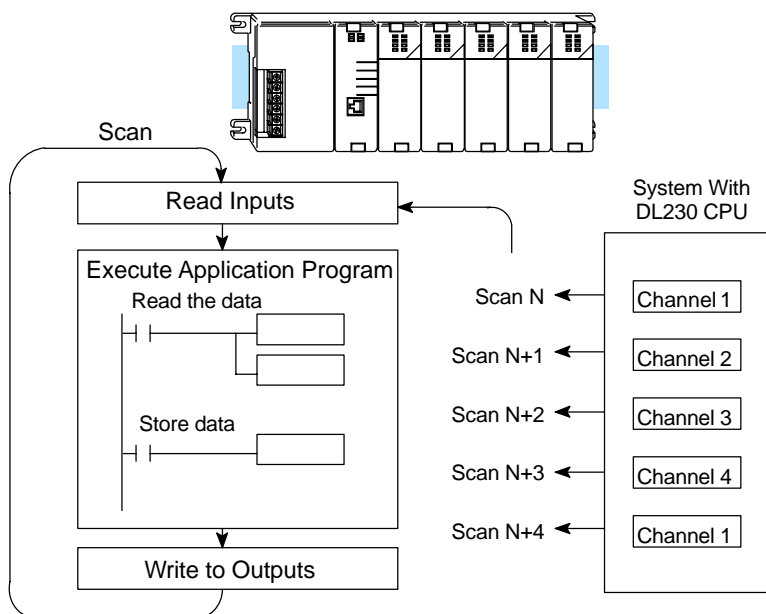

### Channel Scanning Sequence for a DL240, DL250-1 or DL260 CPU (Pointer Method)

If you are using a DL240, DL250-1 or a DL260 CPU, you can obtain all four channels of input data in one scan. This is because the DL240/250-1/260 CPUs support special V-memory locations that are used to manage the data transfer (this is discussed in more detail in the section on Writing the Control Program).

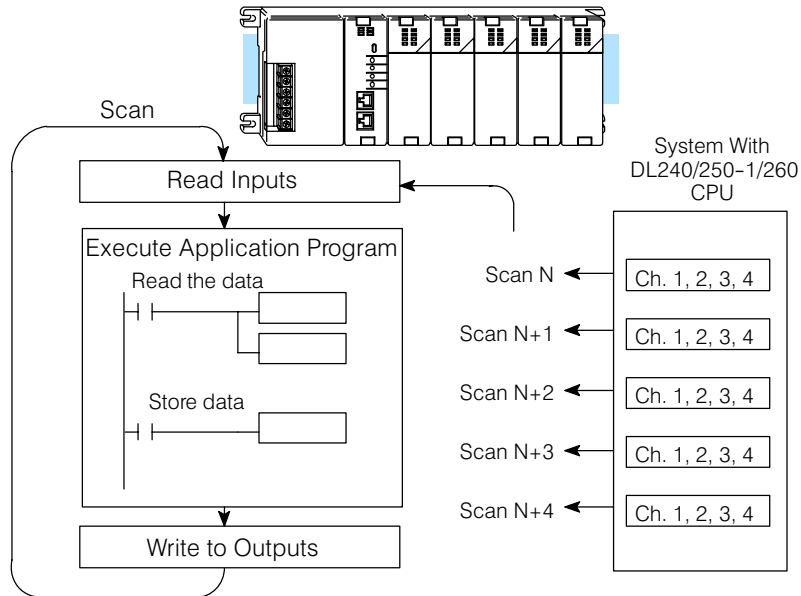

### Analog Module Updates

Even though the channel updates to the CPU are synchronous with the CPU scan, the module asynchronously monitors the analog transmitter signal and converts the signal to a 16-bit binary representation. This enables the module to continuously provide accurate measurements without slowing down the discrete control logic in the stage program.

The time required to sense the temperature and copy the value to V-memory is 160 milliseconds minimum to 640 milliseconds plus 1 scan time maximum (number of channels x 160 milliseconds + 1 scan time).

## Writing the Control Program

### Reading Values: Pointer Method and Multiplexing

There are two methods of reading values:

- The pointer method
- Multiplexing

You *must* use the multiplexing method when using a DL230 CPU. You must also use the multiplexing method with remote I/O modules (the pointer method will not work). You can use either method when using DL240, DL250-1 and DL260 CPUs, but for ease of programming it is strongly recommended that you use the pointer method.

The CPU has special V-memory locations assigned to each base slot that greatly simplify the programming requirements. These V-memory locations:

- specify the number of channels to scan.
- specify the storage locations.

The example program shows how to setup these locations. Place this rung anywhere in the ladder program, or in the initial stage if you are using stage programming instructions. This is all that is required to read the data into V-memory locations. Once the data is in V-memory, you can perform math on the data, compare the data against preset values, and so forth. V2000 is used in the example, but you can use any user V-memory location. In the examples, the module is installed in slot 2. You should enter the V-memory locations used in your application. The pointer method automatically converts values to BCD.

### Pointer Method

×	✓	✓	✓
230	240	250-1	260



**NOTE:** DL240 CPUs with firmware release version 2.5 or later and DL250 CPUs with firmware release version 1.06 or later support this method. Use the DL230 multiplexing example if your firmware revision is earlier.

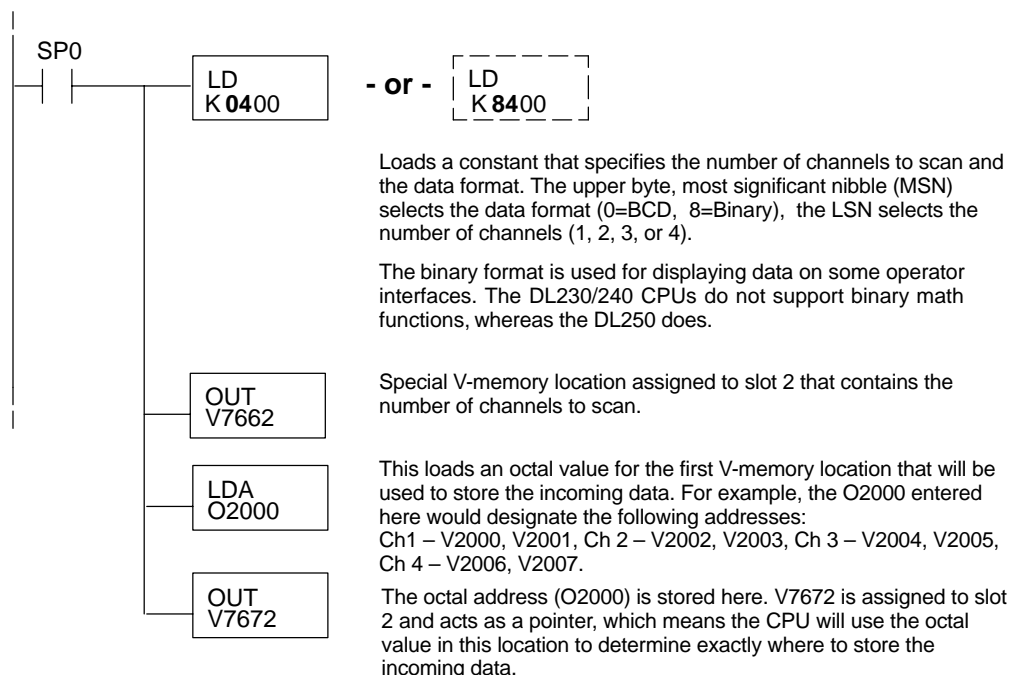

The tables below show the special V-memory locations used by the DL240, DL250–1 and DL260 for the CPU base and local expansion base I/O slots. Slot 0 (zero) is the module next to the CPU or D2–CM module. Slot 1 is the module two places from the CPU or D2–CM, and so on. Remember, the CPU only examines the pointer values at these locations after a mode transition. Also, if you use the DL230 (multiplexing) method, verify that these addresses in the CPU are zero.

The Table below applies to the DL240, DL250–1 and DL260 CPU base.

<b>CPU Base: Analog Input Module Slot-Dependent V-memory Locations</b>								
Slot	0	1	2	3	4	5	6	7
No. of Channels	V7660	V7661	V7662	V7663	V7664	V7665	V7666	V7667
Storage Pointer	V7670	V7671	V7672	V7673	V7674	V7675	V7676	V7677

The Table below applies to the DL250–1 or DL260 expansion base 1.

<b>Expansion Base D2–CM #1: Analog Input Module Slot-Dependent V-memory Locations</b>								
Slot	0	1	2	3	4	5	6	7
No. of Channels	V36000	V36001	V36002	V36003	V36004	V36005	V36006	V36007
Storage Pointer	V36010	V36011	V36012	V36013	V36014	V36015	V36016	V36017

The Table below applies to the DL250–1 or DL260 expansion base 2.

<b>Expansion Base D2–CM #2: Analog Input Module Slot-Dependent V-memory Locations</b>								
Slot	0	1	2	3	4	5	6	7
No. of Channels	V36100	V36101	V36102	V36103	V36104	V36105	V36106	V36107
Storage Pointer	V36110	V36111	V36112	V36113	V36114	V36115	V36116	V36117

The Table below applies to the DL260 CPU expansion base 3.

<b>Expansion Base D2–CM #3: Analog Input Module Slot-Dependent V-memory Locations</b>								
Slot	0	1	2	3	4	5	6	7
No. of Channels	V36200	V36201	V36202	V36203	V36204	V36205	V36206	V36207
Storage Pointer	V36210	V36211	V36212	V36213	V36214	V36215	V36216	V36217

The Table below applies to the DL260 CPU expansion base 4.

<b>Expansion Base D2–CM #4: Analog Input Module Slot-Dependent V-memory Locations</b>								
Slot	0	1	2	3	4	5	6	7
No. of Channels	V36300	V36301	V36302	V36303	V36304	V36305	V36306	V36307
Storage Pointer	V36310	V36311	V36312	V36313	V36314	V36315	V36316	V36317

**Negative Temperature Readings with Magnitude Plus Sign (Pointer Method)**

✗	✓	✓	✓
230	240	250-1	260



With bipolar ranges, you need some additional logic to determine whether the value being returned represents a positive voltage or a negative voltage. For example, you may need to know the direction for a motor. There is a simple solution:

- If you are using bipolar ranges and you get a value greater than or equal to 8000<sub>H</sub>, the value is negative.
- If you get a value less than or equal to 7FFF<sub>H</sub>, the value is positive.

The sign bit is the most significant bit, which combines 8000<sub>H</sub> to the data value. If the value is greater than or equal to 8000<sub>H</sub>, you only have to mask the most significant bit and the active channel bits to determine the actual data value.

**NOTE:** DL240 CPUs with firmware release version 2.5 or later and DL250 CPUs with firmware release version 1.06 or later support this method. Use the DL230 multiplexing example if your firmware revision is earlier.

The following two programs show how you can accomplish this. The first example uses magnitude plus sign (binary) and the second example uses magnitude plus sign (BCD).

Since you always want to know when a value is negative, these rungs should be placed *before* any other operations that use the data, such as math instructions, scaling operations, and so forth. Also, if you are using stage programming instructions, these rungs should be in a stage that is always active. Note: you only need this logic for each channel that is using bipolar input signals. The examples only show two channels.

**Magnitude Plus Sign (Binary)**

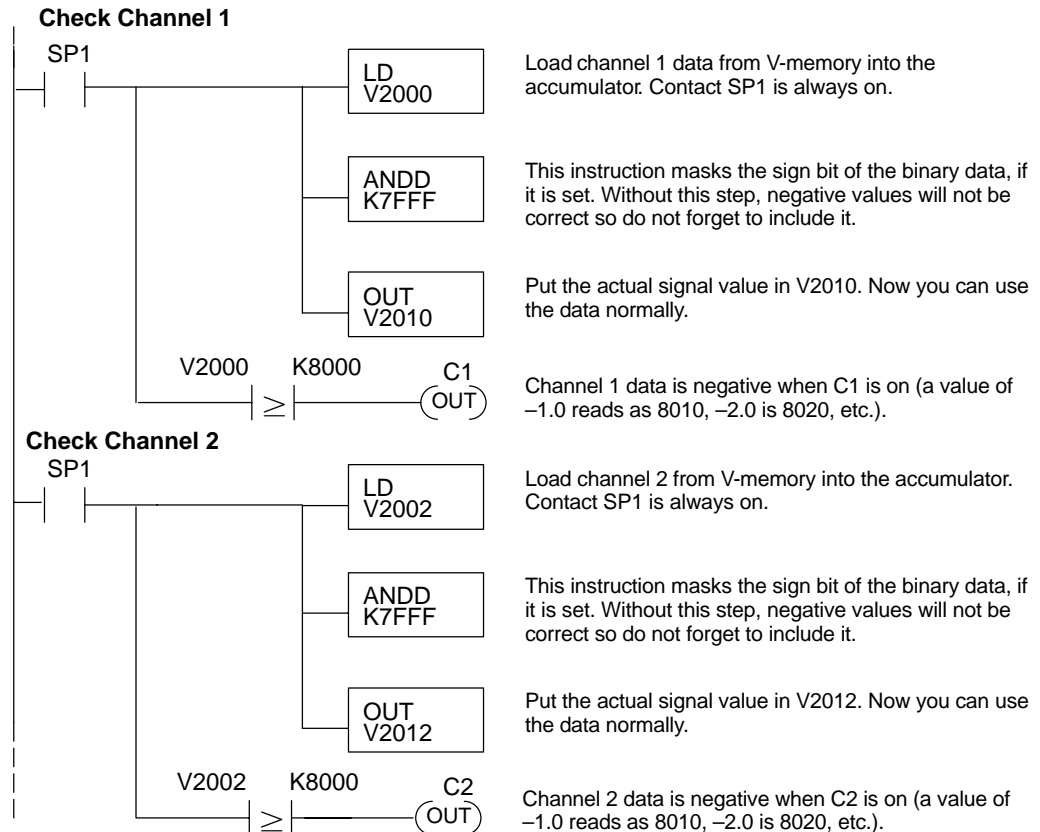

### Magnitude Plus Sign (BCD)

F2-04THM  
4-Ch. Thermocouple

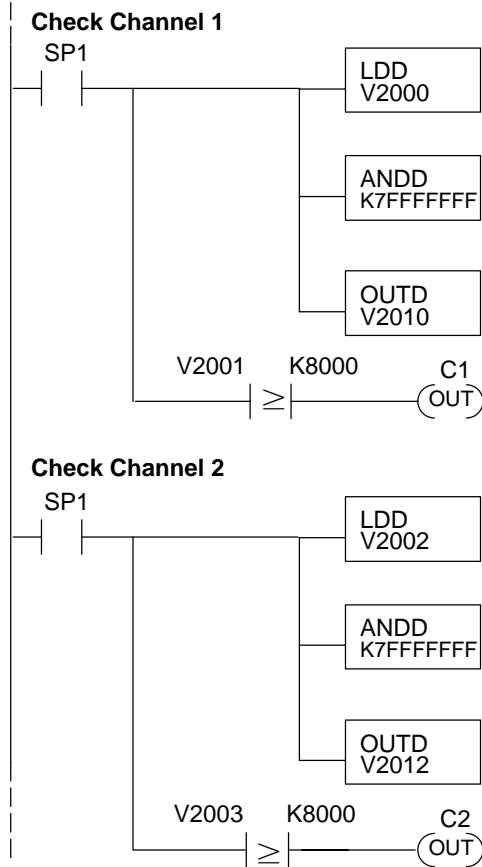

Load channel 1 data from V-memory into the accumulator. Remember, the data can be negative. Contact SP1 is always on.

This instruction masks the sign bit of the BCD data, if it is set. Without this step, negative values will not be correct so do not forget to include it.

Put the actual signal value in V2010. Now you can use the data normally.

Channel 1 data is negative when C1 is on (a value of -1.0 reads as 8000 0010, -2.0 is 8000 0020, etc.).

Load channel 2 from V-memory into the accumulator. Remember, the data can be negative. Contact SP1 is always on.

This instruction masks the sign bit of the BCD data, if it is set. Without this step, negative values will not be correct so do not forget to include it.

Put the actual signal value in V2012. Now you can use the data normally.

Channel 2 data is negative when C2 is on (a value of -1.0 reads as 8000 0010, -2.0 is 8000 0020, etc.).

**Negative Temperatures 2's Complement (Binary / Pointer Method)**

230  
  240  
  250-1  
  260

You can use the 2's complement mode for negative temperature display purposes while at the same time using the magnitude plus sign of the temperature in your control program. The *DirectSOFT32* element Signed Decimal is used to display negative numbers in 2's complement form. To find the absolute value of a negative number in 2's complement, invert the number and add 1 as shown in the following example:

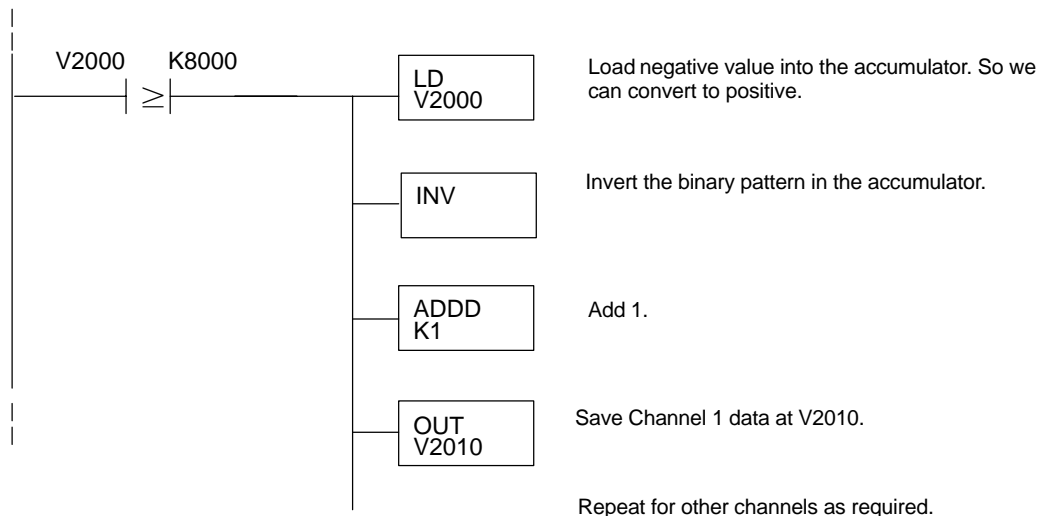

F2-04THM  
4 Ch. Thermocouple

**Understanding the Input Assignments (Multiplexing Ladder Only)**

230  
  240  
  250-1  
  260

You may recall that the F2-04THM module appears to the CPU as a 32-point discrete input module. You can use these points to obtain:

- An indication of which channel is active
- The digital representation of the analog signal
- Module diagnostic information

Since all input points are automatically mapped into V-memory, it is very easy to determine the location of the data word that will be assigned to the module.

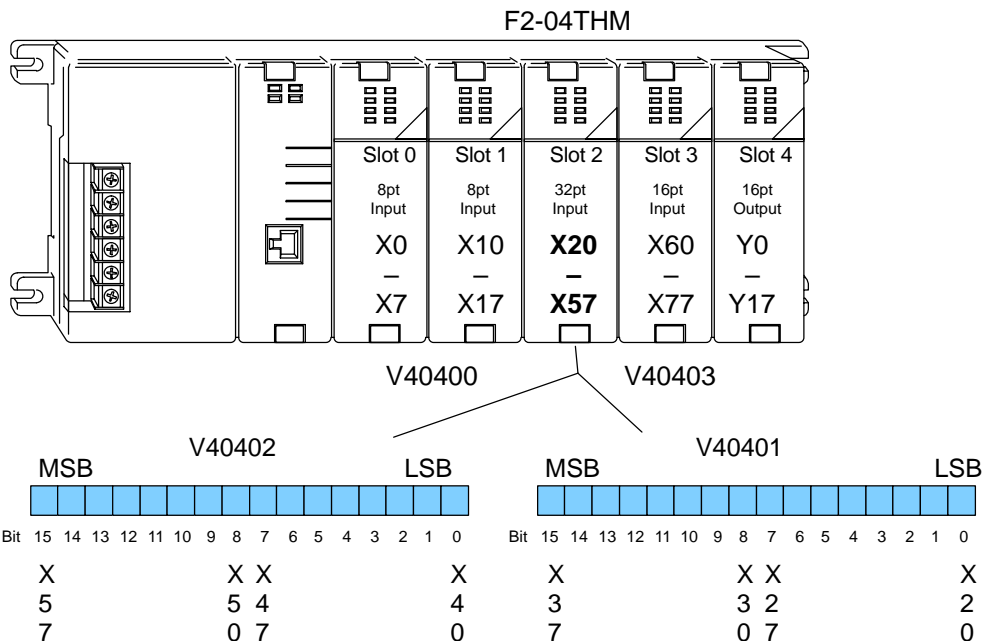

Remember, when using DL230 CPUs input points must start on a V-memory boundary. To use the V-memory references required for a DL230 CPU, the *first* input address assigned to the module must be one of the following X locations. The table also shows the V-memory addresses that correspond to these X locations.

<b>X</b>	X0	X20	X40	X60	X100	X120	X140	X160
<b>V</b>	V40400	V40401	V40402	V40403	V40404	V40405	V40406	V40407

### Analog Data Bits

The first 16 bits represent the analog data in binary format.

Bit	Value	Bit	Value
0	1	8	256
1	2	9	512
2	4	10	1024
3	8	11	2048
4	16	12	4096
5	32	13	8192
6	64	14	16384
7	128	15	32768

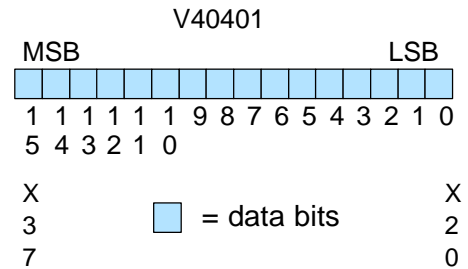

### Active Channel Bits

The active channel bits represent the multiplexed channel selections in binary format.

Bit 1	Bit 0	Channel
0	0	1
0	1	2
1	0	3
1	1	4

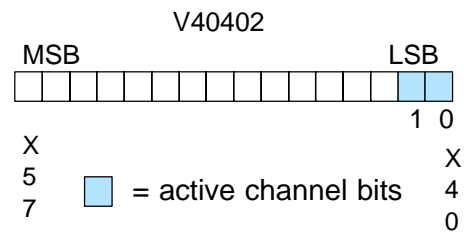

### Broken Transmitter Bits (Pointer and Multiplexing Ladder Methods)

The broken transmitter bits are on when the corresponding thermocouple is open.

Bit	Channel
8	1
9	2
10	3
11	4

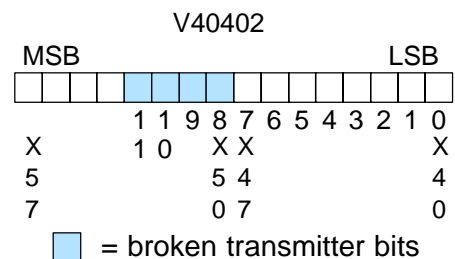

**Reading  
Magnitude Plus  
Sign Values  
(Multiplexing)**

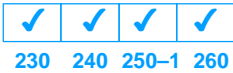

The DL230 CPU *does not* have the special V-memory locations that allow you to automatically enable the data transfer. Since all channels are multiplexed into a single data word, the control program must be setup to determine which channel is being read. Since the module appears as X input points to the CPU, it is very easy to use the active channel status bits to determine which channel is being monitored.

**NOTE:** DL230 CPUs with firmware release version 1.6 or later is required for multiplexing ladder.

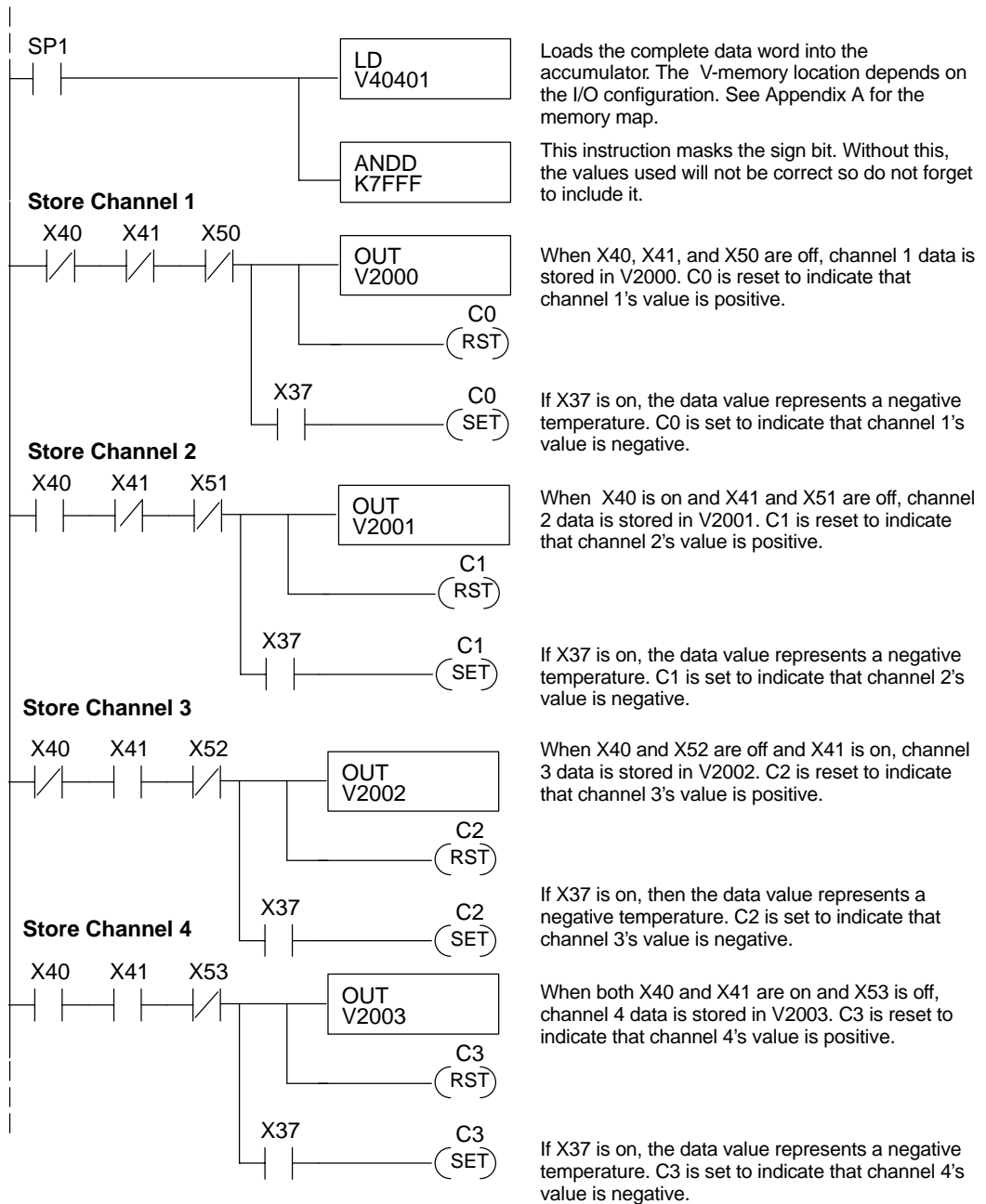

**Reading 2's Complement Values (Multiplexing)**



The DL230 CPU *does not* have the special V-memory locations that allow you to automatically enable the data transfer. Since all channels are multiplexed into a single data word, the control program must be setup to determine which channel is being read. Since the module appears as X input points to the CPU, it is very easy to use the active channel status bits to determine which channel is being monitored. The 2's complement data format may be required to correctly display bipolar data on some operator interfaces. This data format could also be used to simplify averaging a bipolar signal. To view this data format in **DirectSOFT32**, select Signed Decimal.

F2-04THM 4-Ch. Thermocouple

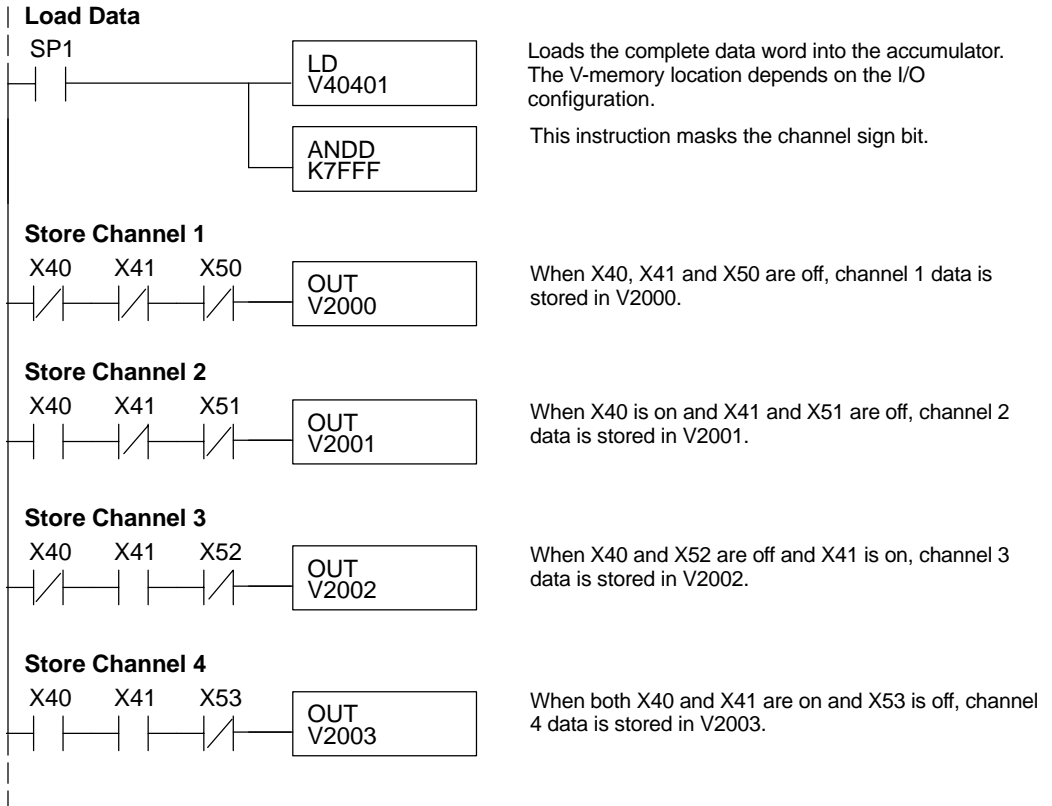

**Scaling the Input Data**

No scaling of the input temperature is required. The readings directly reflect the actual temperatures. For example: a reading of 8482 is 848.2 °C, a reading of 16386 is -0.2°C. (magnitude plus sign), and a reading of 32770 is -0.2°C (2's complement).

**Module Resolution  
16-Bit (Unipolar  
Voltage Input)**

Unipolar analog signals are converted into 65536 counts ranging from 0 to 65535 ( $2^{16}$ ). For example, with a 0 to 156mV signal range, 78mV would be 32767. A value of 65535 represents the upper limit of the range.

$$\text{Unipolar Resolution} = \frac{H - L}{65535}$$

H or L = high or low limit of the range

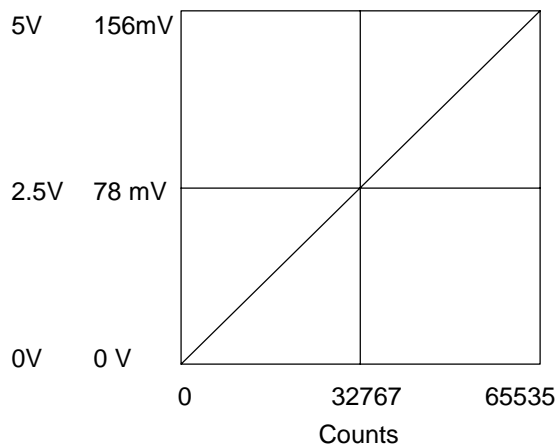
**Module Resolution  
15-Bit Plus Sign  
(Bipolar Voltage  
Input)**

The module has 16-bit unipolar or 15-bit + sign bipolar resolution. Bipolar analog signals are converted into 32768 counts ranging from 0 to 32767 ( $2^{15}$ ). For example, with a -156mV to 156mV signal range, 156mV would be 32767. The bipolar ranges utilize a sign bit to provide 16-bit resolution. A value of 32767 can represent the upper limit of either side of the range. Use the sign bit to determine negative values.

$$\text{Bipolar Resolution} = \frac{H - L}{32767}$$

H or L = high or low limit of the range

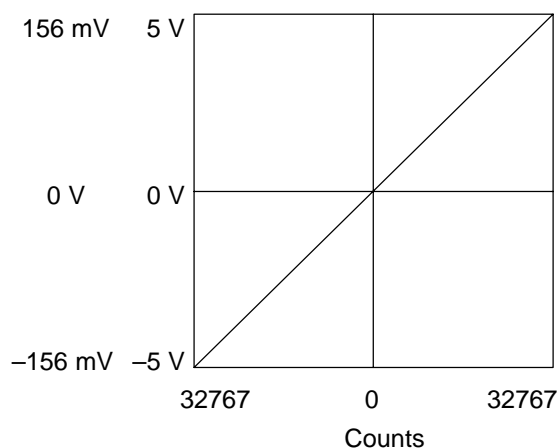

### Analog and Digital Value Conversions

Sometimes it is useful to be able to quickly convert between the signal levels and the digital values. This is especially helpful during machine startup or troubleshooting. Remember, this module *does not* operate like other versions of analog input modules that you may be familiar with. The bipolar ranges use 0–32767 for both positive and negative voltages. The sign bit allows this and it actually provides better resolution than those modules that do not offer a sign bit. The following table provides formulas to make this conversion easier.

Range	If you know the digital value ...	If you know the signal level ...
0 to 5V	$A = \frac{5D}{65535}$	$D = \frac{65535}{5} (A)$
0 to 156.25mV	$A = \frac{0.15625D}{65535}$	$D = \frac{65535}{0.15625} (A)$
±5V	$A = \frac{10D}{65535}$	$D = \frac{65535}{10} (A)$
±156.25mV	$A = \frac{0.3125D}{65535}$	$D = \frac{65535}{0.3125} (A)$

For example, if you are using the ±5V range and you have measured the signal at 2.5V, use the following formula to determine the digital value that is stored in the V-memory location that contains the data.

$$D = \frac{65535}{10} (A)$$

$$D = \frac{65535}{10} (2.5V)$$

$$D = (6553.5) (2.5)$$

$$D = 16383.75$$

**Filtering Input Noise (DL250-1, DL260 CPUs Only)**

✗	✗	✓	✓
230	240	250-1	260

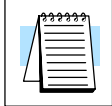

Add the following logic to filter and smooth analog input noise in DL250-1 and DL260 CPUs. This is especially useful when using PID loops. Noise can be generated by the field device and/or induced by field wiring.

The analog value in BCD is first converted to a binary number because there is not a BCD-to-real conversion instruction. Memory location V1400 is the designated workspace in this example. The MULR instruction is the filter factor, which can be from 0.1 to 0.9. The example uses 0.2. A smaller filter factor increases filtering. You can use a higher precision value, but it is not generally needed. The filtered value is then converted back to binary and then to BCD. The filtered value is stored in location V1402 for use in your application or PID loop.

**NOTE:** Be careful not to do a multiple number conversion on a value. For example, if you are using the pointer method to get the analog value, it is in BCD and must be converted to binary. However, if you are using the conventional method of reading analog and are masking the first fifteen bits, then it is already in binary and no conversion using the BIN instruction is needed. Also, if you are using the conventional method, change the LLD V2000 instruction to LD V2000.

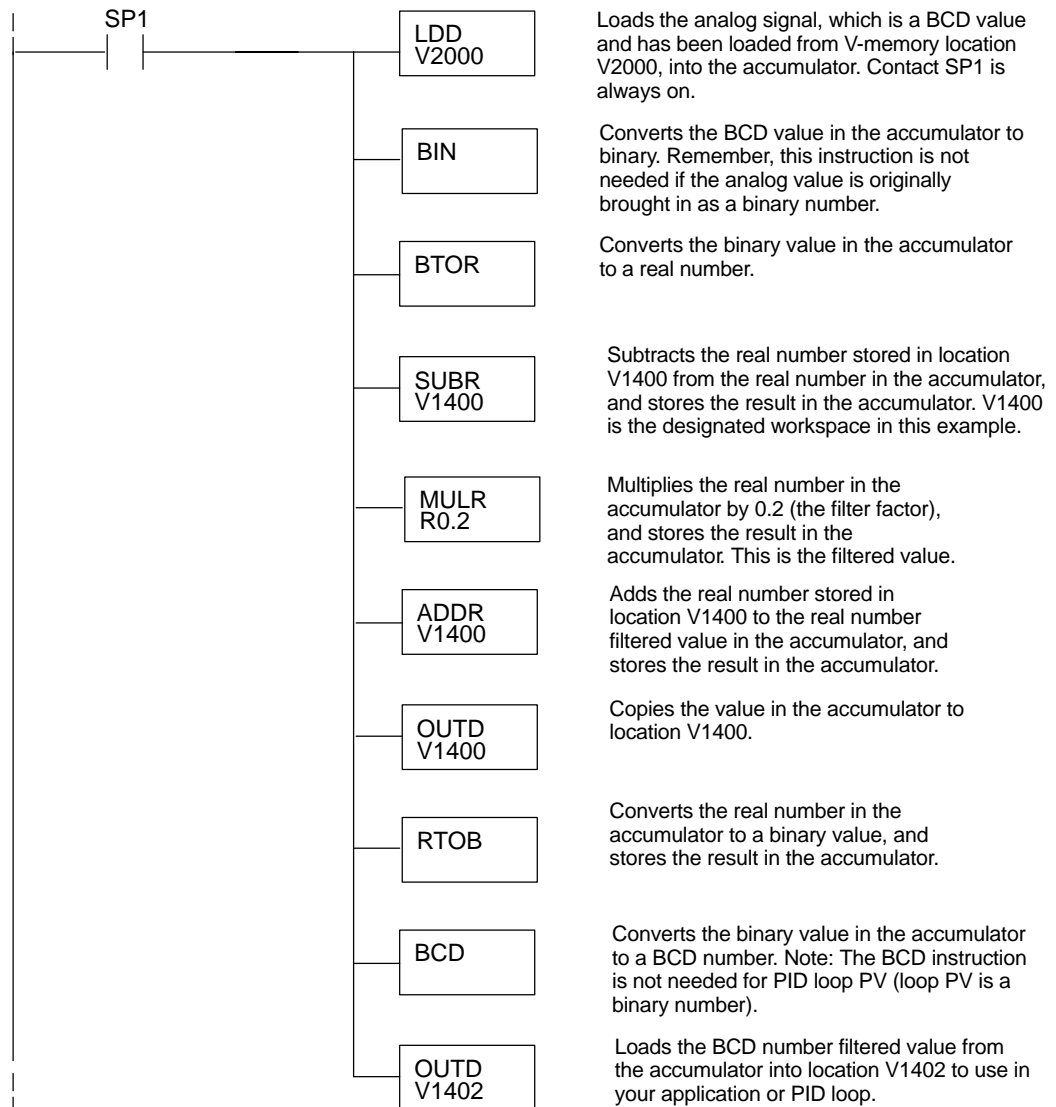

# **F2-02DA-1, F2-02DA-1L 2-Channel Analog Current Output**

---

In This Chapter. . . .

- Module Specifications
  - Connecting the Field Wiring
  - Module Operation
  - Writing the Control Program
-

## Module Specifications

The F2-02DA-1 and F2-02DA-1L Analog Output modules provide several hardware features:

- Analog outputs are optically isolated from the PLC logic.
- The module has a removable terminal block so the module can be easily removed or changed without disconnecting the wiring.
- With a DL240, DL250-1 or DL260 CPU, you can update both channels in one scan.
- F2-02DA-1: Low-power CMOS design requires less than 60mA from an external 18-30 VDC power supply.
- F2-02DA-1L: Low-power CMOS design requires less than 70mA from an external 10-15 VDC power supply.

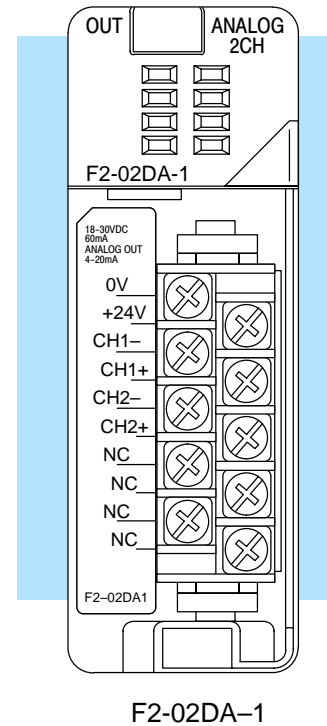

**NOTE:** The F2-02DA-1 and F2-02DA-1L modules look very similar and it is very easy to mistake one module for the other. If your module does not work, check the terminal label to see if you have a 12 volts (L) or a 24 volts model and that it is being supplied with the proper input voltage.

The following tables provide the specifications for the F2-02DA-1 and F2-02DA-1L Analog Output Modules. Review these specifications to make sure the module meets your application requirements.

### Output Specifications

Number of Channels	2
Output Ranges	4 to 20 mA
Resolution	12 bit (1 in 4096)
Output Type	Single ended, 1 common
Maximum Loop Supply	30VDC
Peak Output Voltage	40VDC (clamped by transient voltage suppressor)
Load Impedance	0 $\Omega$ minimum
Maximum Load / Power Supply	620 $\Omega$ /18V, 910 $\Omega$ /24V, 1200 $\Omega$ /30V
Linearity Error (end to end)	$\pm 1$ count ( $\pm 0.025\%$ of full scale) maximum
Conversion Settling time	100 $\mu$ s maximum (full scale change)
Full-Scale Calibration Error (offset error included)	$\pm 5$ counts maximum, 20mA @ 25°C (77°F)
Offset Calibration Error	$\pm 3$ counts maximum, 4mA @ 25°C (77°F)
Maximum Inaccuracy	0.1% @ 25°C (77°F) 0.3% @ 0 to 60°C (32 to 140°F)
Accuracy vs. Temperature	$\pm 50$ ppm/°C full scale calibration change (including maximum offset change of 2 counts)

### General Specifications

PLC Update Rate	1 channel per scan maximum (D2-230 CPU) 2 channels per scan maximum (D2-240/250-1/260 CPU)
Digital outputs Output points required	12 binary data bits, 2 channel ID bits 16 point (Y) output module
Power Budget Requirement	40 mA @ 5 VDC (supplied by base)
External Power Supply	F2-02DA-1: 18-30 VDC, 60 mA F2-02DA-1L: 12-15 VDC, 70 mA (add 20 mA for each current loop used)
Operating Temperature	0 to 60° C (32 to 140° F)
Storage Temperature	-20 to 70° C (-4 to 158° F)
Relative Humidity	5 to 95% (non-condensing)
Environmental air	No corrosive gases permitted
Vibration	MIL STD 810C 514.2
Shock	MIL STD 810C 516.2
Noise Immunity	NEMA ICS3-304

One count in the specification table is equal to one least significant bit of the analog data value (1 in 4096).

### Analog Output Configuration Requirements

The F2-02DA-1 (L) Analog output appears as a 16-point discrete output module. The module can be installed in any slot if you are using a DL240 CPU (firmware V1.5 or later) or DL250 CPU. The available power budget and discrete I/O points are the limiting factors. Check the user manual for your particular model of CPU and I/O base for more information regarding power budget and number of local, local expansion or remote I/O points.

**Special Placement Requirements (DL230 and Remote I/O Bases)**

It is important to examine the configuration if you are using a DL230 CPU. As you can see in the section on writing the program, you use V-memory locations to send the analog data. If you place the module so that the output points do not start on a V-memory boundary, the instructions cannot access the data. This also applies when placing this module in a remote base using a D2-RSSS in the CPU slot.

**Correct!**

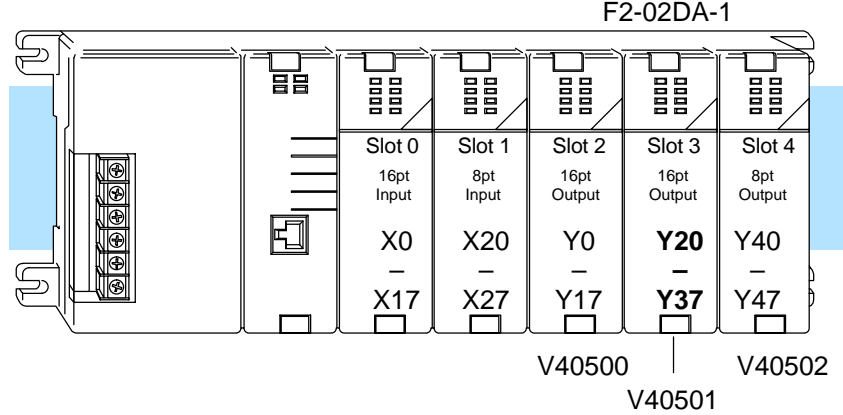

Data is correctly entered so output points start on V-memory boundary.

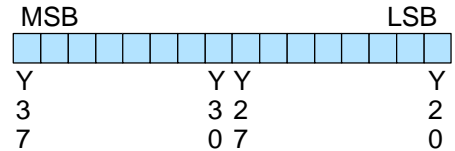

**Incorrect**

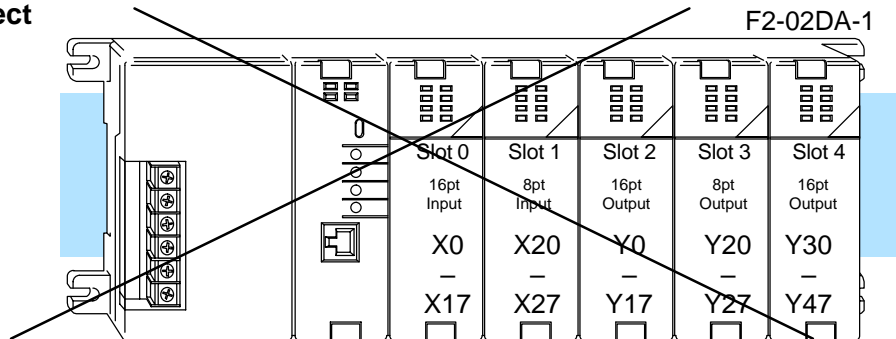

Data is split over two locations, so instructions cannot access data from a DL230.

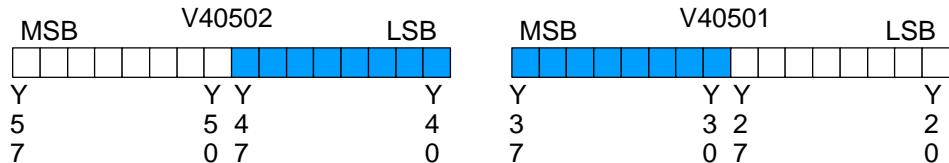

To use the required V-memory references, the *first* output address assigned to the module must be one of the following Y locations. The table also shows the V-memory addresses that correspond to these Y locations.

<b>Y</b>	Y0	Y20	Y40	Y60	Y100	Y120	Y140	Y160
<b>V</b>	V40500	V40501	V40502	V40503	V40504	V40505	V40506	V40507

## Connecting the Field Wiring

### Wiring Guidelines

Your company may have guidelines for wiring and cable installation. If so, you should check those before you begin the installation. Here are some general things to consider:

- Use the shortest wiring route whenever possible.
- Use shielded wiring and ground the shield at the signal source. *Do not* ground the shield at both the module and the load.
- Do not run the signal wiring next to large motors, high current switches, or transformers. This may cause noise problems.
- Route the wiring through an approved cable housing to minimize the risk of accidental damage. Check local and national codes to choose the correct method for your application.

### User Power Supply Requirements

The F2-02DA-1 (L) requires at least one field-side power supply. You may use the same or separate power sources for the module supply and loop supply. The module requires 18–30VDC, at 60 mA. The two current loops also require 18–30VDC, but at 20 mA each.

The DL205 bases have built-in 24 VDC power supplies that provide up to 300mA of current. You may use this instead of a separate supply if you are using only a couple of analog modules. The current required is 60 mA (module) plus 40 mA (two current loops) for a total of 100 mA.

It is desirable in some situations to power the loops separately in a location remote from the PLC. This will work as long as the loop supply meets the voltage and current requirements, and the transmitter's minus (–) side and the module supply's minus (–) side are connected together.

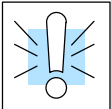

---

**WARNING:** If you are using the 24 VDC base power supply, make sure you calculate the power budget. Exceeding the power budget can cause unpredictable system operation that can lead to a risk of personal injury or damage to equipment.

---

**Wiring Diagram**

The F2-02DA-1 (L) module has a removable connector to make wiring easier. Simply squeeze the top and bottom retaining clips and gently pull the connector from the module. Use the following diagram to connect the field wiring. The diagram shows separate module and loop power supplies. If you desire to use only one field-side supply, just combine the supplies' positive (+) terminals into one node and remove the loop supply.

NOTE 1: Shields should be connected to the 0V terminal of the module or 0V of the power supply.  
 NOTE 2: Unused current outputs should remain open (no connections) for minimum power consumption.

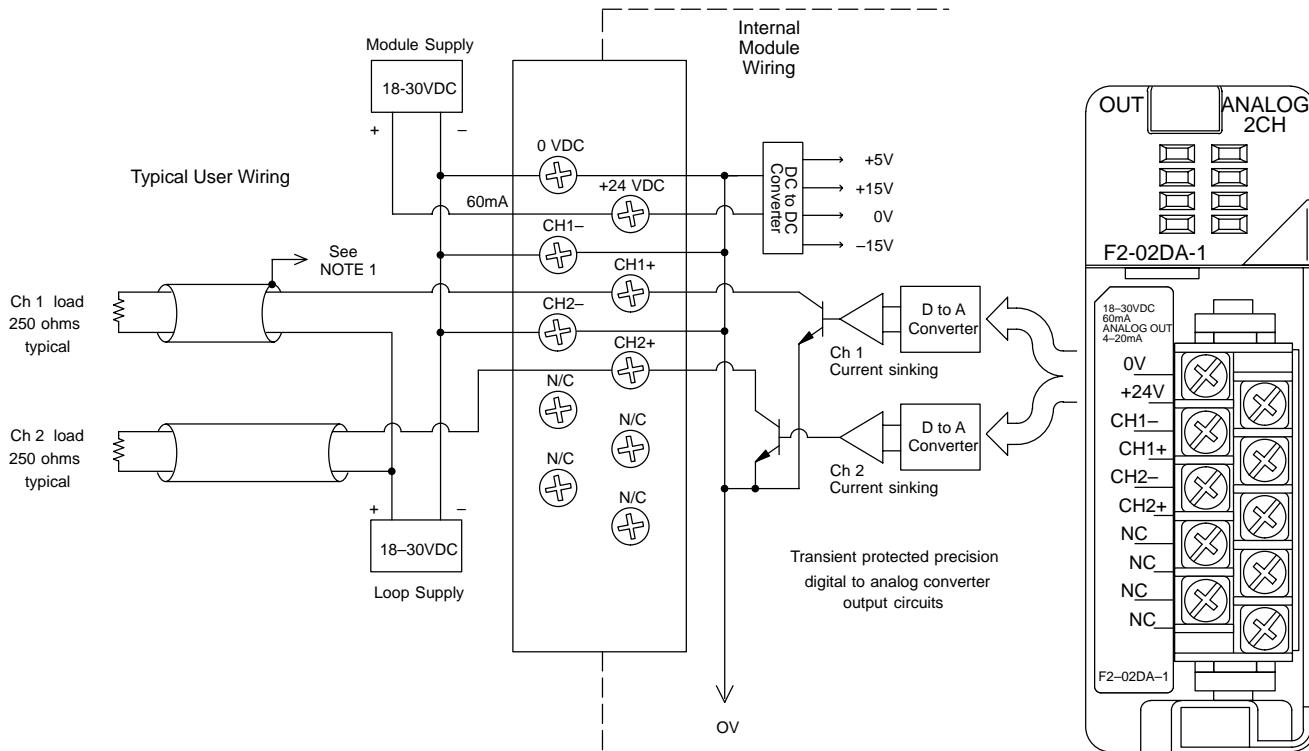

F2-02DA-1, (L)  
2-Ch. Current Output

**Load Range**

The maximum load resistance depends on the particular loop power supply in use.

Loop Power Supply Voltage	Acceptable Load Range
30 VDC	0 to 1200Ω
24 VDC	0 to 910Ω
18 VDC	0 to 620Ω

## Module Operation

### Channel Update Sequence for a DL230 CPU (Multiplexing)

Before you begin writing the control program, it is important to take a few minutes to understand how the module processes and represents the analog signals.

If you are using a DL230 CPU, you can send one channel of data to the output module on each scan. The module refreshes both field devices on each scan, but you can only get new data from the CPU at the rate of one channel per scan. Since there are two channels, it can take two scans to update both channels. However, if you are only using one channel, then you can update that channel on every scan. The multiplexing method can also be used for the DL240/250-1/260 CPUs.

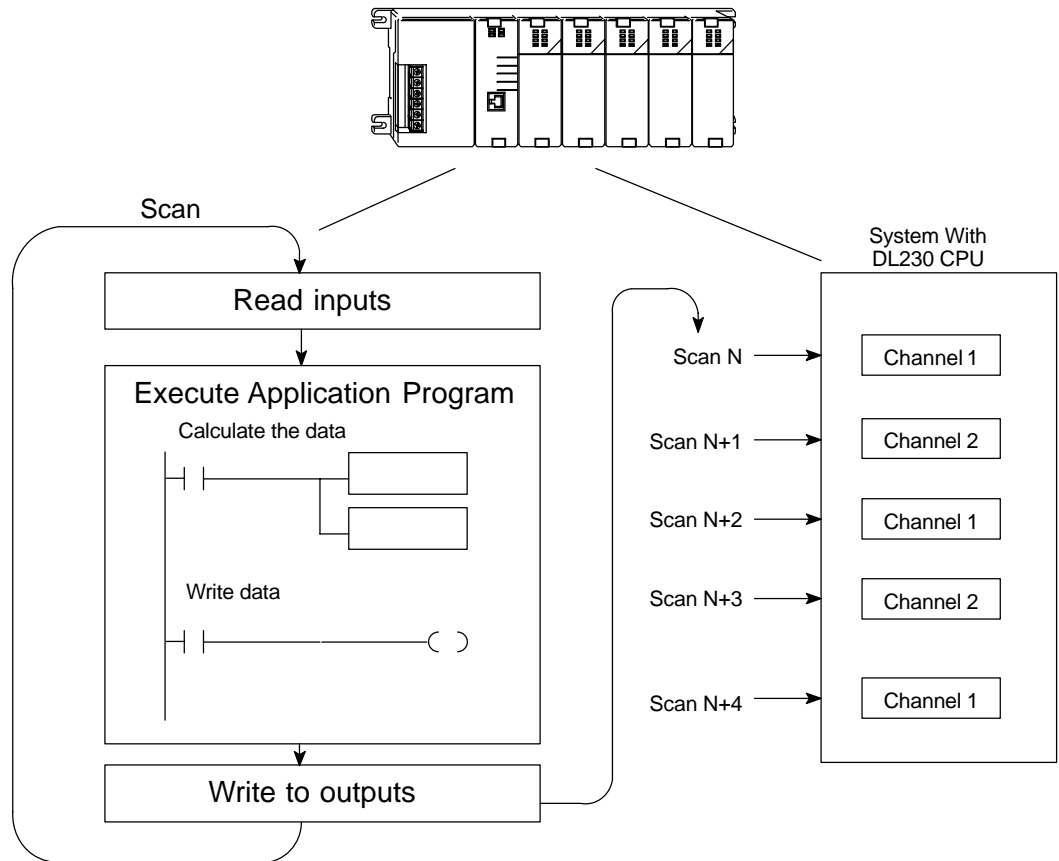

**Channel Scanning Sequence for a DL240, DL250-1 or DL260 CPU (Pointer Method)**

If you are using a DL240, DL250-1 or DL260 CPU, you can update both channels on every scan. This is because those CPUs support special V-memory locations that are used to manage the data transfer. This is discussed in more detail in the section on Writing the Control Program.

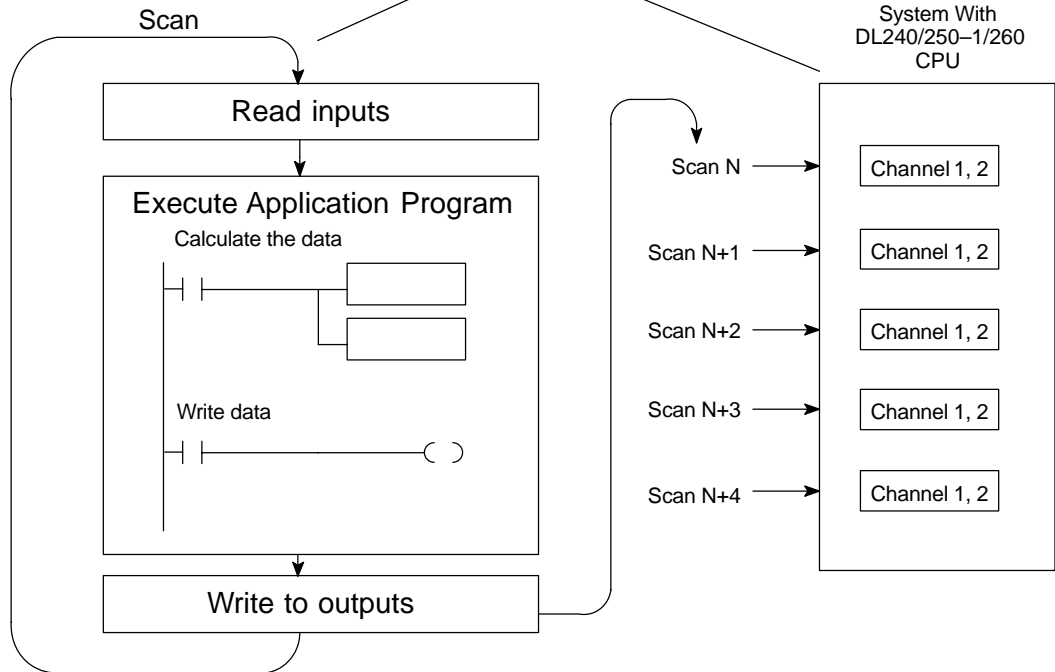
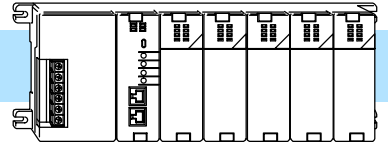

F2-02DA-1, (L)  
2-Ch. Current Output

**Understanding the Output Assignments**

You may recall the F2-02DA-1 (L) module appears to the CPU as a 16-point discrete output module. These points provide the data value and an indication of which channel to update. Note, if you are using a DL240/250260 CPU, you may never have to use these bits, but it may help you understand the data format.

Since all output points are automatically mapped into V-memory, it is very easy to determine the location of the data word that will be assigned to the module.

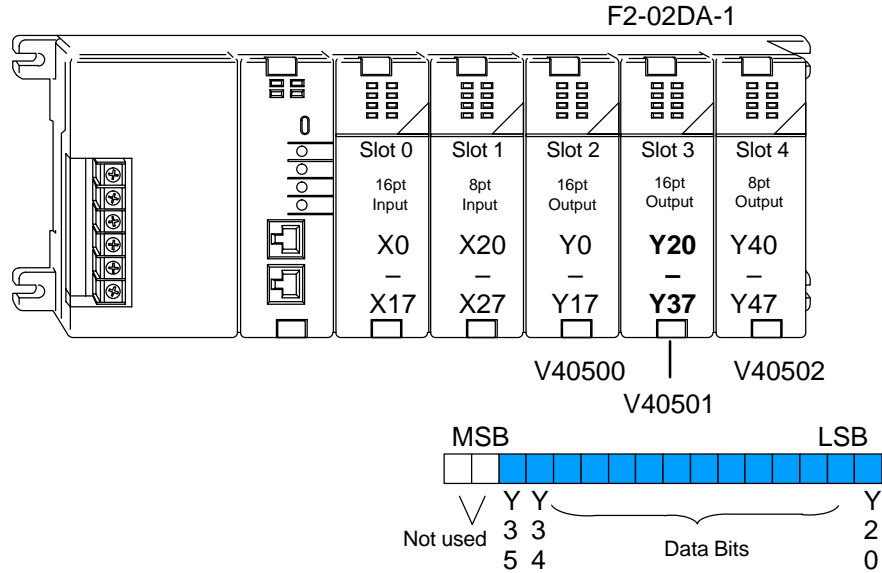

Within this word location, the individual bits represent specific information about the analog signal.

**Channel Select Outputs**

Two of the outputs select the active channel. Remember, the V-memory bits are mapped directly to discrete outputs. Turning a bit OFF selects its channel. By controlling these outputs, you can select which channel(s) gets updated.

Y35	Y34	Channel
On	Off	1
Off	On	2
Off	Off	1 & 2 (same data to both channels)
On	On	none (both channels hold current values)

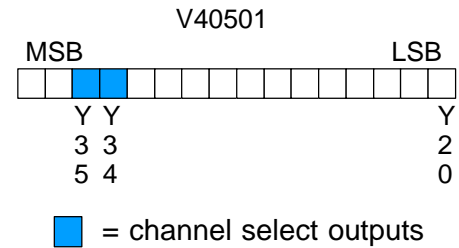

■ = channel select outputs

F2-02DA-1, (L)  
2-Ch. Current Output

**Analog Data Bits** The first twelve bits represent the analog data in binary format.

Bit	Value	Bit	Value
0	1	6	64
1	2	7	128
2	4	8	256
3	8	9	512
4	16	10	1024
5	32	11	2048

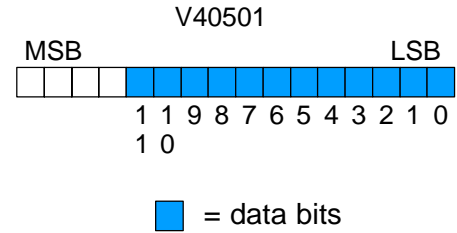

**Module Resolution**

Since the module has 12-bit resolution, the analog signal is converted into 4096 counts ranging from 0 – 4095 ( $2^{12}$ ). For example, send a 0 to get a 4mA signal and 4095 to get a 20mA signal. This is equivalent to a binary value of 0000 0000 0000 to 1111 1111 1111, or 000 to FFF hexadecimal. The diagram shows how this relates to the signal range.

Each count can also be expressed in terms of the signal level by using the equation shown.

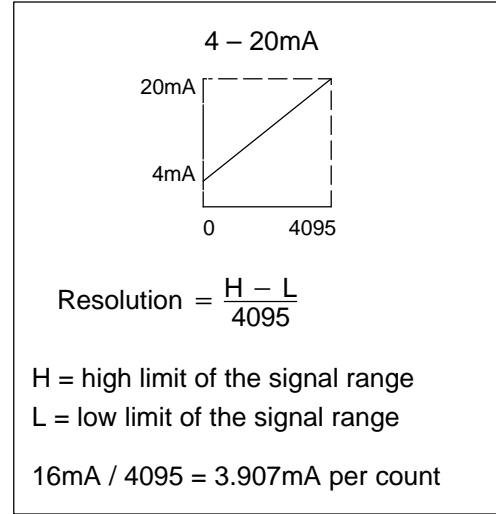

# Writing the Control Program

## Reading Values: Pointer Method and Multiplexing

There are two methods of reading values:

- The pointer method
- Multiplexing

You *must* use the multiplexing method when using a DL230 CPU. You must also use the multiplexing method with remote I/O modules (the pointer method will not work). You can use either method when using DL240, DL250-1 and DL260 CPUs, but for ease of programming it is strongly recommended that you use the pointer method.

### Pointer Method

X	✓	✓	✓
230	240	250-1	260



Once you have calculated the data values (shown previously) you have to enter the program that actually updates the module. The DL240/250-1/260 has special V-memory locations assigned to each base slot that greatly simplify the programming requirements. By using these V-memory locations you can:

- specify the number of channels to update.
- specify where to obtain the output data.

**NOTE:** DL240 CPUs with firmware version 1.5 or later and DL250 CPUs with firmware version 1.06 or later support this method. If using the DL230 example, module placement in the base is very important. Refer to the earlier module placement section.

The following program example shows how to set up these locations. Place this rung anywhere in the ladder program, or in the initial stage when using stage programming. The pointer method automatically converts values to BCD.

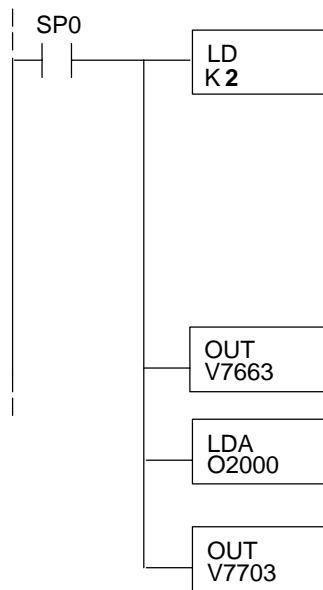

- or -

Loads a constant that specifies the number of channels to scan and the data format. The lower byte, most significant nibble (MSN) selects the data format (i.e. 0=BCD, 8=Binary), the LSN selects the number of channels (1 or 2).

The binary format is used for displaying data on some operator interfaces. The DL230/240 CPUs do not support binary math functions, whereas the DL250 does.

Special V-memory location assigned to slot 3 that contains the number of channels to scan.

This loads an octal value for the first V-memory location that will be used to store the output data. For example, the O2000 entered here would designate the following addresses.  
Ch1 - V2000, Ch2 - V2001

The octal address (O2000) is stored here. V7703 is assigned to slot 3 and acts as a pointer, which means the CPU will use the octal value in this location to determine exactly where to store the output data.

The tables below show the special V-memory locations used by the DL240, DL250–1 and DL260 for the CPU base and local expansion base I/O slots. Slot 0 (zero) is the module next to the CPU or D2–CM module. Slot 1 is the module two places from the CPU or D2–CM, and so on. Remember, the CPU only examines the pointer values at these locations after a mode transition. Also, if you use the DL230 (multiplexing) method, verify that these addresses in the CPU are zero.

The Table below applies to the DL240, DL250–1 and DL260 CPU base.

CPU Base: Analog Output Module Slot-Dependent V-memory Locations								
Slot	0	1	2	3	4	5	6	7
No. of Channels	V7660	V7661	V7662	V7663	V7664	V7665	V7666	V7667
Storage Pointer	V7700	V7701	V7702	V7703	V7704	V7705	V7706	V7707

The Table below applies to the DL250–1 or DL260 expansion base 1.

Expansion Base D2–CM #1: Analog Output Module Slot-Dependent V-memory Locations								
Slot	0	1	2	3	4	5	6	7
No. of Channels	V36000	V36001	V36002	V36003	V36004	V36005	V36006	V36007
Storage Pointer	V36020	V36021	V36022	V36023	V36024	V36025	V36026	V36027

The Table below applies to the DL250–1 or DL260 expansion base 2.

Expansion Base D2–CM #2: Analog Output Module Slot-Dependent V-memory Locations								
Slot	0	1	2	3	4	5	6	7
No. of Channels	V36100	V36101	V36102	V36103	V36104	V36105	V36106	V36107
Storage Pointer	V36120	V36121	V36122	V36123	V36124	V36125	V36126	V36127

The Table below applies to the DL260 CPU expansion base 3.

Expansion Base D2–CM #3: Analog Output Module Slot-Dependent V-memory Locations								
Slot	0	1	2	3	4	5	6	7
No. of Channels	V36200	V36201	V36202	V36203	V36204	V36205	V36206	V36207
Storage Pointer	V36220	V36221	V36222	V36223	V36224	V36225	V36226	V36227

The Table below applies to the DL260 CPU expansion base 4.

Expansion Base D2–CM #4: Analog Output Module Slot-Dependent V-memory Locations								
Slot	0	1	2	3	4	5	6	7
No. of Channels	V36300	V36301	V36302	V36303	V36304	V36305	V36306	V36307
Storage Pointer	V36320	V36321	V36322	V36323	V36324	V36325	V36326	V36327

**Writing Data  
(Multiplexing )**



The DL230 CPU *does not* have the special V-memory locations that allow you to automatically enable the data transfer. Since all channels are multiplexed into a single data word, the control program must be setup to determine which channel to write. Since the module appears as Y output points to the CPU, it is very easy to use the channel selection outputs to determine which channel to update.

Note, this example is for a module installed as shown in the previous examples. The addresses used would be different if the module was used in a different slot. You can place these rungs anywhere in the program or if you are using stage programming, place them in a stage that is always active.

This example is a two-channel multiplexer that updates each channel on alternate scans. Relay SP7 is a special relay that is on for one scan, then off for one scan.



**NOTE:** You must send binary data to the module. If the data is already in binary format, you should not use the BIN instruction shown in this example.

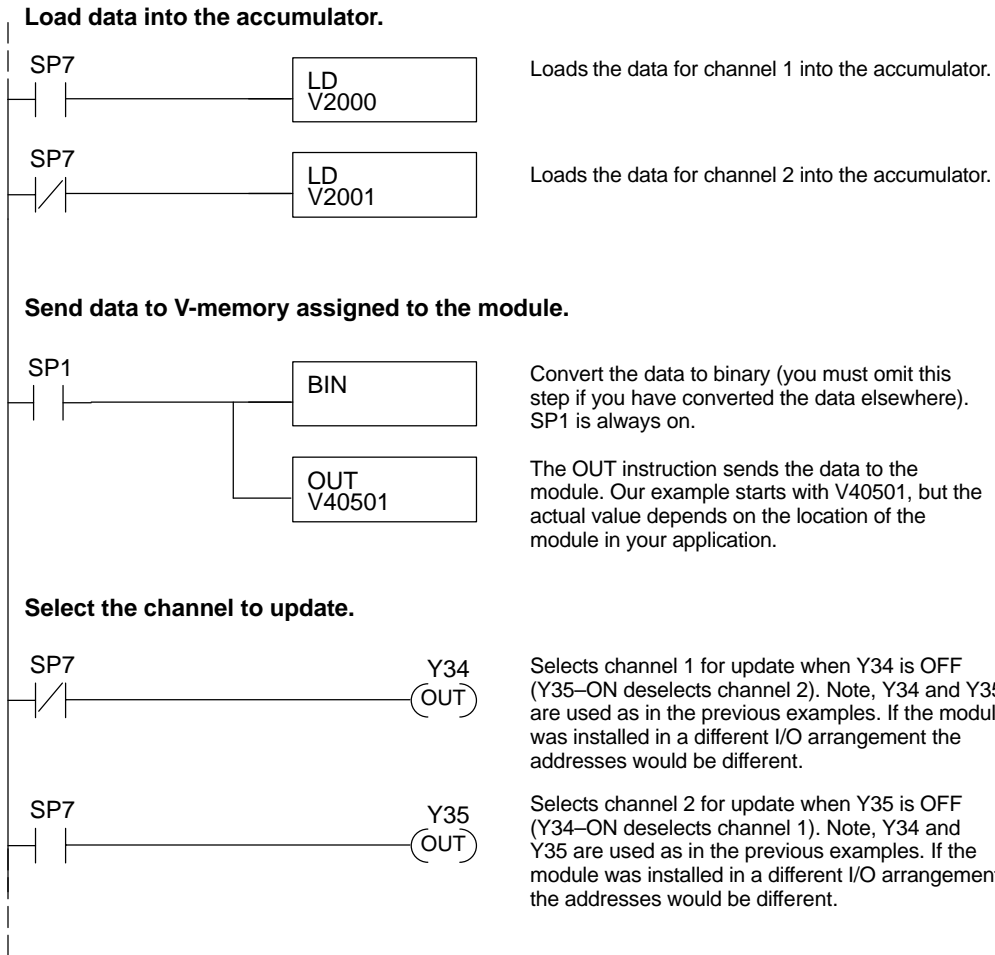

F2-02DA-1, (L)  
2-Ch. Current Output

### Sending Data to One Channel

If you are not using both channels, or if you want to control the updates separately, use the following program.

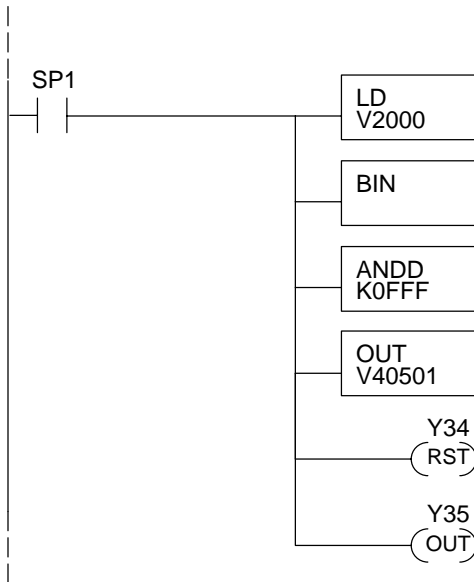

The LD instruction loads the data into the accumulator. Since SP1 is used, this rung automatically executes on every scan. You could also use an X, C, etc. permissive contact.

The BIN instruction converts the accumulator data to binary (you must omit this step if you have already converted the data elsewhere).

This AND Double instruction logically ANDs the accumulator with the constant FFF. It keeps the data from affecting channel select bits.

The OUT instruction sends the data to the module. Our example starts with V40501, but the actual value depends on the location of the module in your application.

Y34-OFF selects channel 1 for updating.

Y35-ON deselected channel 2 (do not update).

### Sending the Same Data to Both Channels

If both channel selection outputs are off, both channels will be updated with the same data.

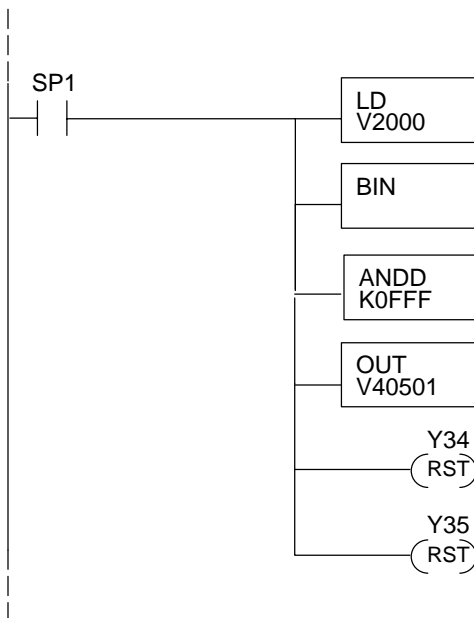

The LD instruction loads the data into the accumulator. Since SP1 is used, this rung automatically executes on every scan. You could also use an X, C, etc. permissive contact.

The BIN instruction converts the accumulator data to binary (you must omit this step if you have already converted the data elsewhere).

The AND Double instruction logically ANDs the accumulator value with the constant FFF. It keeps the data from affecting channel select bits.

The OUT instruction sends the data to the module. Our example starts with V40501, but the actual value depends on the location of the module in your application.

Y34-OFF selects channel 1 for updating.

Y35-OFF selects channel 2 for updating.

**Calculating the Digital Value**

Your program must calculate the digital value to send to the analog module. There are many ways to do this, but most applications are understood more easily if you use measurements in engineering units. This is accomplished by using the conversion formula shown.

You may have to make adjustments to the formula depending on the scale you choose for the engineering units.

$$A = U \frac{4095}{H - L}$$

A = Analog value (0 – 4095)

U = Engineering Units

H = high limit of the engineering unit range

L = low limit of the engineering unit range

Consider the following example which controls pressure from 0.0 to 99.9 PSI. By using the formula, you can easily determine the digital value that should be sent to the module. The example shows the conversion required to yield 49.4 PSI. Notice the formula uses a multiplier of 10. This is because the decimal portion of 49.4 cannot be loaded, so you adjust the formula to compensate for it.

$$A = 10U \frac{4095}{10(H - L)}$$

$$A = 494 \frac{4095}{1000 - 0}$$

$$A = 2023$$

**Analog and Digital Value Conversions**

Sometimes it is useful to be able to quickly convert between the signal levels and the digital values. This is especially helpful during machine startup or troubleshooting. The following table provides formulas to make this conversion easier.

Range	If you know the digital value ...	If you know the signal level ...
4 to 20mA	$A = \frac{16D}{4095} + 4$	$D = \frac{4095}{16}(A - 4)$

For example, if you know you need a 10mA signal to achieve the desired result, you can easily determine the digital value that should be used.

$$D = \frac{4095}{16}(A - 4)$$

$$D = \frac{4095}{16}(10\text{mA} - 4)$$

$$D = (255.93) (6)$$

$$D = 1536$$

The example program shows how you would write the program to perform the engineering unit conversion. This example assumes you have calculated or loaded the engineering unit values in BCD and stored them in V2300 and V2301 for channels 1 and 2 respectively.



**NOTE:** The DL205 offers various instructions that allow you to perform math operations using BCD format. It is easier to perform math calculations in BCD and then convert the value to binary before sending the data to the module.

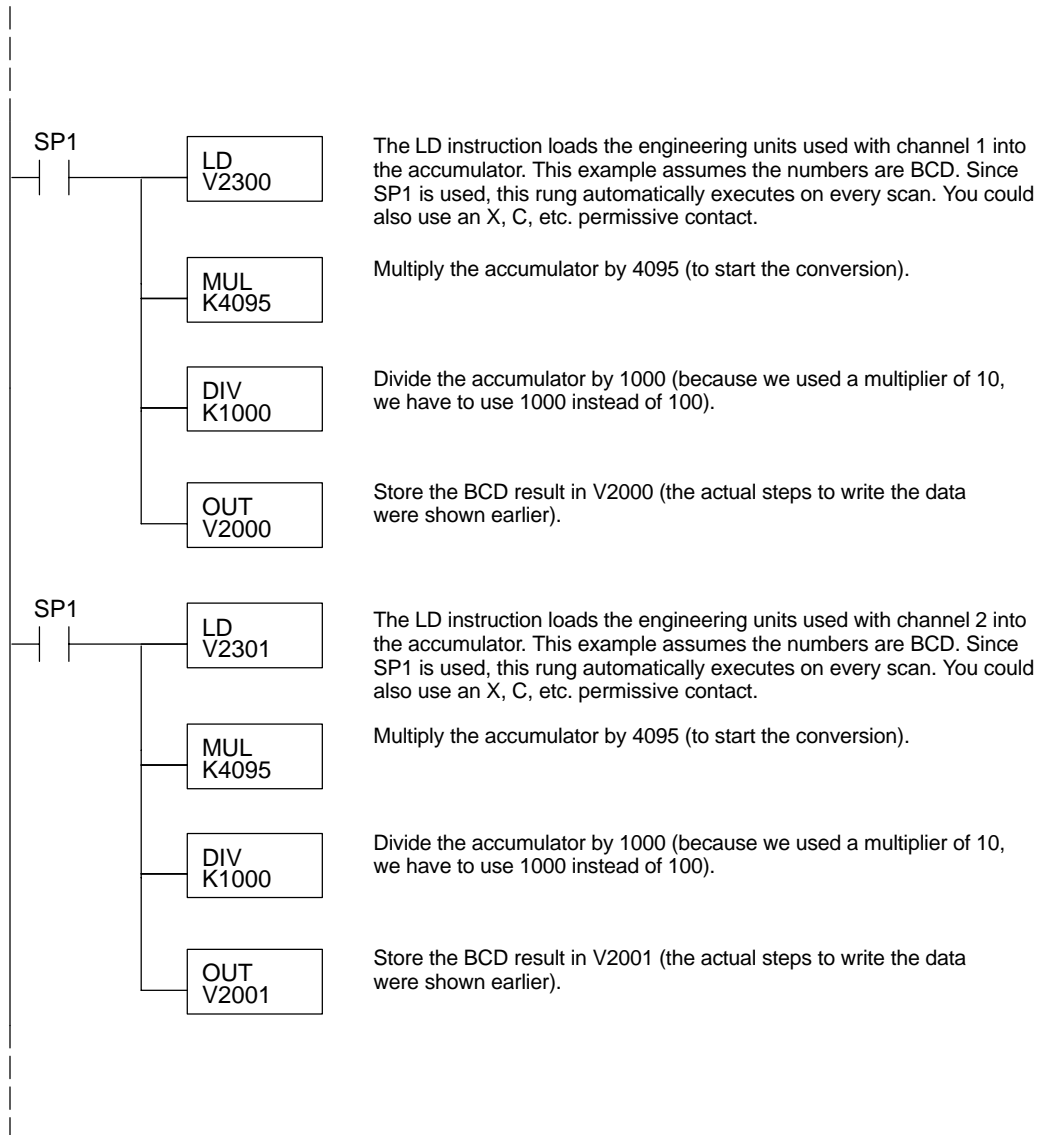

# **F2-02DA-2, F2-02DA-2L 2-Channel Analog Voltage Output**

---

In This Chapter. . . .

- Module Specifications
  - Setting the Module Jumpers
  - Connecting the Field Wiring
  - Module Operation
  - Writing the Control Program
-

## Module Specifications

The F2-02DA-2 and F2-02DA-2L Analog Output modules provide several hardware features:

- Analog outputs are optically isolated from the PLC logic.
- The module has a removable terminal block, so the module can be easily removed or changed without disconnecting the wiring.
- With a DL240, DL250-1 or DL260 CPU, you can update both channels in one scan.
- F2-02DA-2: Low-power CMOS design requires less than 60mA from an external 18–30 VDC power supply.
- F2-02DA-2L: Low-power CMOS design requires less than 70mA from an external 10–15 VDC power supply.
- Outputs can be independently configured for any of these four ranges:
  - 1) 0 to 5 VDC
  - 2) 0 to 10 VDC
  - 3)  $\pm 5$  VDC
  - 4)  $\pm 10$  VDC

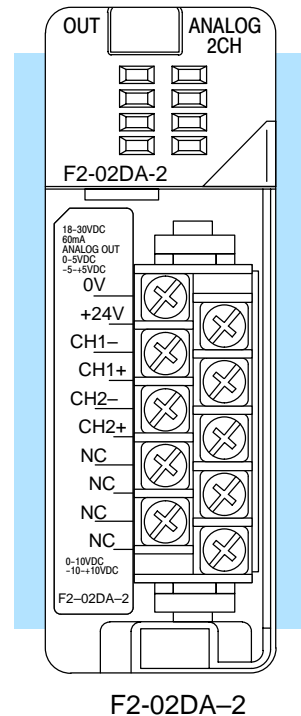

F2-02DA-2

**NOTE:** The F2-02DA-2 and F2-02DA-2L modules look very similar and it is very easy to mistake one module for the other. If your module does not work, check the terminal label to see if you have a 12 volts (L) or a 24 volts model and that it is being supplied with the proper input voltage.

The following tables provide the specifications for the F2-02DA-2 and F2-02DA-2L Analog Output Modules. Review these specifications to make sure the module meets your application requirements.

### Output Specifications

Number of Channels	2
Output Ranges	0 to 5V, 0 to 10V, $\pm 5V$ , $\pm 10V$
Resolution	12 bit (1 in 4096)
Output Type	Single ended, 1 common
Peak Output Voltage	15VDC (clamped by transient voltage suppressor)
Load Impedance	2000 $\Omega$ minimum
Load Capacitance	.01 $\mu$ F maximum
Linearity Error (end to end)	$\pm 1$ count ( $\pm 0.025\%$ of full scale) maximum
Conversion Settling Time	5 $\mu$ s maximum (full scale change)
Full-Scale Calibration Error (offset error included)	$\pm 12$ counts max. unipolar @ 25°C (77°F) $\pm 16$ counts max. bipolar @ 25°C (77°F)
Offset Calibration Error	$\pm 3$ counts maximum @ 25°C (77°F) unipolar $\pm 8$ counts maximum @ 25°C (77°F) bipolar
Accuracy vs. Temperature	$\pm 50$ ppm/°C full scale calibration change (including maximum offset change of 2 counts)
Maximum Inaccuracy	Unipolar ranges $\pm 0.3\%$ @ 25°C (77°F) $\pm 0.45\%$ 0–60°C (32–140°F) Bipolar ranges $\pm 0.4\%$ @ 25°C (77°F) $\pm 0.55\%$ 0–60°C (32–140°F)

### General Specifications

PLC Update Rate	1 channel per scan maximum (D2-230 CPU) 2 channels per scan maximum (D2-240/250-1/ 260 CPU)
Digital Outputs Output Points Required	12 binary data bits, 2 channel ID bits, 1 sign bit 16 point (Y) output module
Power Budget Requirement	40 mA @ 5 VDC (supplied by base)
External Power Supply	F2-02DA-2: 18-30 VDC, 60 mA (outputs fully loaded) F2-02DA-2L: 10-15 VDC, 70 mA (outputs fully loaded)
Operating Temperature	0 to 60° C (32 to 140° F)
Storage Temperature	-20 to 70° C (-4 to 158° F)
Relative Humidity	5 to 95% (non-condensing)
Environmental Air	No corrosive gases permitted
Vibration	MIL STD 810C 514.2
Shock	MIL STD 810C 516.2
Noise Immunity	NEMA ICS3-304

One count in the specification table is equal to one least significant bit of the analog data value (1 in 4096).

### Analog Output Configuration Requirements

The F2-02DA-2 (L) analog output requires 16 discrete output points. The module can be installed in any slot of a DL205 system, but the available power budget and discrete I/O points can be limiting factors. Check the user manual for your particular model of CPU and I/O base for more information regarding power budget and number of local, local expansion or remote I/O points.

**Special Placement Requirements (DL230 and Remote I/O Bases)**

Even though the module can be placed in any slot, it is important to examine the configuration if you are using a DL230 CPU. As you can see in the section on writing the program, you use V-memory locations to extract the analog data. If you place the module so the output points do not start on a V-memory boundary, the instructions cannot access the data. This also applies when placing this module in a remote I/O base using a D2-RSSS in the CPU slot.

**Correct!**

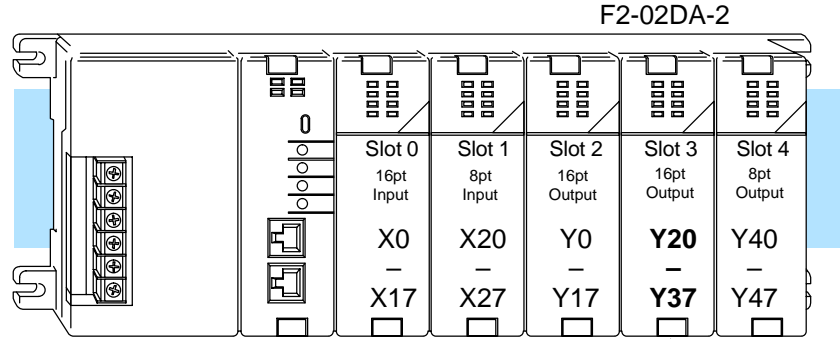

Data is correctly entered so output points start on a V-memory boundary.

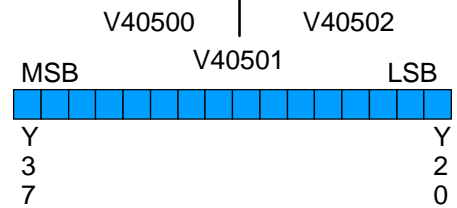

**Incorrect**

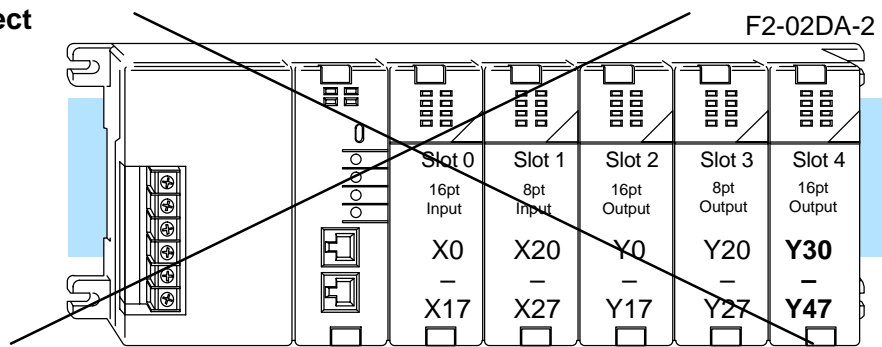

Data is split over two locations, so instructions cannot access data from a DL230.

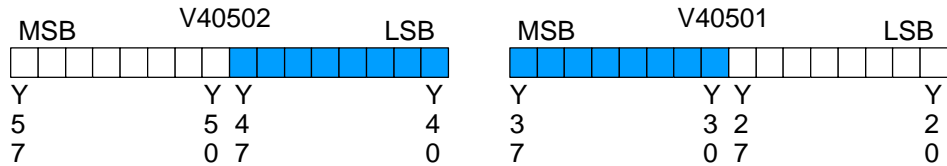

To use the V-memory references required for a DL230 CPU, the *first* output address assigned to the module must be one of the following Y locations. The table also shows the V-memory addresses that correspond to these Y locations.

<b>Y</b>	Y0	Y20	Y40	Y60	Y100	Y120	Y140	Y160
<b>V</b>	V40500	V40501	V40502	V40503	V40504	V40505	V40506	V40507

F2-02DA-2, (L)  
2-Ch. Voltage Output

# Setting the Module Jumpers

The F2-02DA-2 (L) Analog Output module uses jumpers for selecting the voltage ranges for each channel. The range of each channel can be independently set. Available operating ranges are 0-5V, 0-10V, ±5V, and ±10V.

There are three jumpers for each channel. Two sets are on the top board, and the third set is along the edge of the bottom board *with* the black D-shell backplane connector. Install or remove these jumpers to select the desired range. Unused jumpers can be stored on a single pin so they do not get lost.

- Two of the top board jumpers are labeled “UNI / ±5” and there is one for each channel.
- The two bottom board jumpers are labeled “UNI” and there is one for each channel. These jumpers determine the format of the channel output data, and the effect of their settings is independent from that of the other jumpers on the module. With a UNI jumper removed, the corresponding channel requires data values in the range of ±2047. With a UNI jumper installed, the channel requires data values in the range of 0 to 4095.
- The other two top board jumpers are labeled “BI-P 0-5” and there is one for each channel. These jumpers each have three possible settings (including jumper removed) since there are three pins.



**NOTE:** It is important to set the module jumpers correctly. The module will not operate correctly if the jumpers are not properly set for the desired voltage range.

This figure shows the jumper locations. See the table on the following page to determine the proper settings for your application.

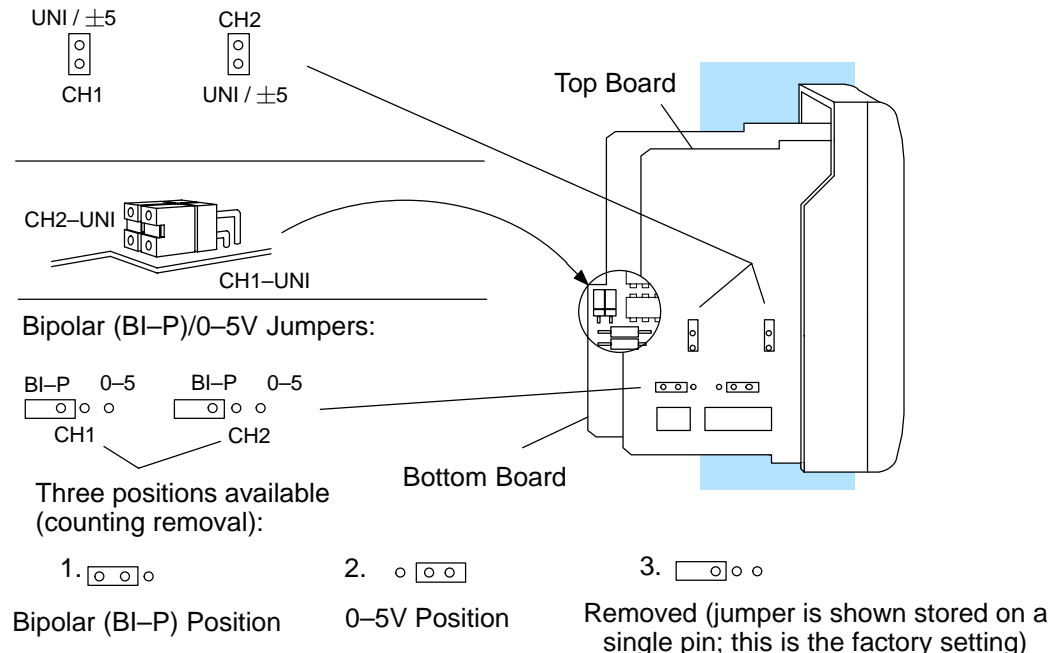

F2-02DA-2, (L)  
2-Ch. Voltage Output

### Voltage Range and Output Combinations

The table lists the eight possible combinations of voltage ranges and data formats, along with the corresponding jumper settings. For most applications, use one of the four standard selections shown in the shaded blocks in the table. Standard unipolar voltage ranges accept a data format of 0 to 4095. Standard bipolar ranges accept a data format of  $-2047$  to  $+2047$ .

Voltage Range	Output Data Format	UNI / $\pm 5V$ Jumpers Settings (top board)	UNI Output Format Jumpers Settings (bottom board)	BI-P 0-5V Jumpers Settings (top board)	
				BI-P (Bipolar) Position	0-5V Position
0 to 5V	0 to 4095	Install	Install		Install here
0 to 10V	0 to 4095	Install	Install	Completely remove	
0 to 5V	$\pm 2047$	Install	Remove		Install here
0 to 10V	$\pm 2047$	Install	Remove	Completely remove	
$\pm 5V$	$\pm 2047$	Install	Remove	Install here	
$\pm 10V$	$\pm 2047$	Remove	Remove	Install here	
$\pm 5V$	0 to 4095	Install	Install	Install here	
$\pm 10V$	0 to 4095	Remove	Install	Install here	

 Standard selections are shown in shaded cells in the table.

For example, to select settings of “ $\pm 5V$ ” voltage range with a “ $\pm 2047$ ” output data format for channel 1, refer to the table above and the figure on the previous page and arrange the jumpers as follows:

- Install the “CH1” “UNI /  $\pm 5V$ ” jumper.
- Remove the “CH1-UNI” jumper. Store the jumper so it does not get lost by placing it on one pin.
- Install the “CH1” “BI-P 0-5” jumper in the BI-P (bipolar) position on the left pin and center pin.

The non-standard selections in the table provide the opposite data format for both unipolar and bipolar voltage ranges. If you are using unipolar output (0-5V or 0-10V) on one channel and bipolar output ( $\pm 5V$ ,  $\pm 10V$ ) on the other channel, then one of the outputs will use a non-standard data format.

The graphs show the voltage range to output data format relationship for each of the eight selections.

**Unipolar Ranges**

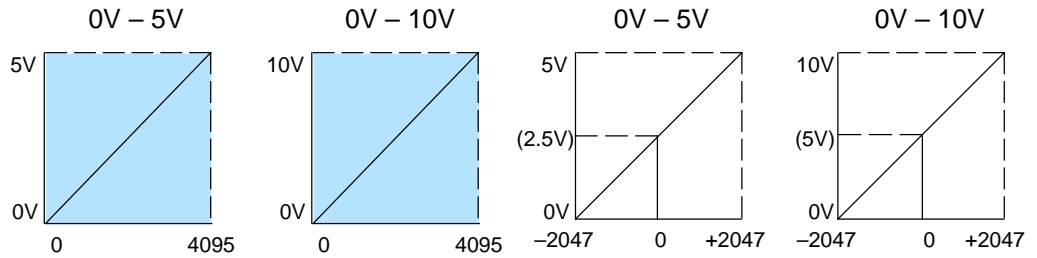

**Bipolar Ranges**

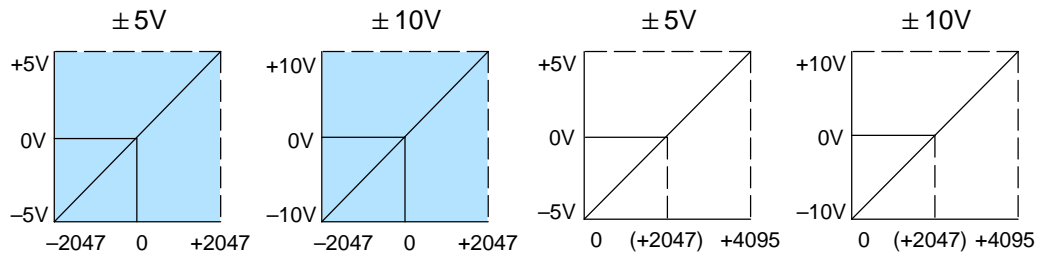

# Connecting the Field Wiring

## Wiring Guidelines

Your company may have guidelines for wiring and cable installation. If so, you should check those before you begin the installation. Here are some general things to consider:

- Use the shortest wiring route whenever possible.
- Use shielded wiring and ground the shield at the signal source. *Do not* ground the shield at both the module and the load.
- Do not run the signal wiring next to large motors, high current switches, or transformers. This may cause noise problems.
- Route the wiring through an approved cable housing to minimize the risk of accidental damage. Check local and national codes to choose the correct method for your application.

## User Power Supply Requirements

The F2-02DA-2 (L) requires a separate field-side power supply. Each module requires 18–30 VDC at up to 60mA current. The DL205 bases have built-in 24 VDC power supplies that provide up to 300mA of current. If you are using only a couple of analog modules, you can use this power source instead of a separate supply. If you want to use a separate supply, choose one that meets the power requirements of your application.



**WARNING:** If you are using the 24 VDC base power supply, make sure you calculate the power budget. Exceeding the power budget can cause unpredictable system operation that can lead to a risk of personal injury or damage to equipment.

## Wiring Diagram

The F2-02DA-2 (L) module has a removable connector to make wiring easier. Simply remove the retaining screws and gently pull the connector from the module. Use the following diagram to connect the field wiring.

NOTE 1: Shields should be connected to the 0V terminal of the module or the 0V terminal of the power supply.

NOTE 2: Unused voltage outputs should remain open (no connections) for minimum power consumption.

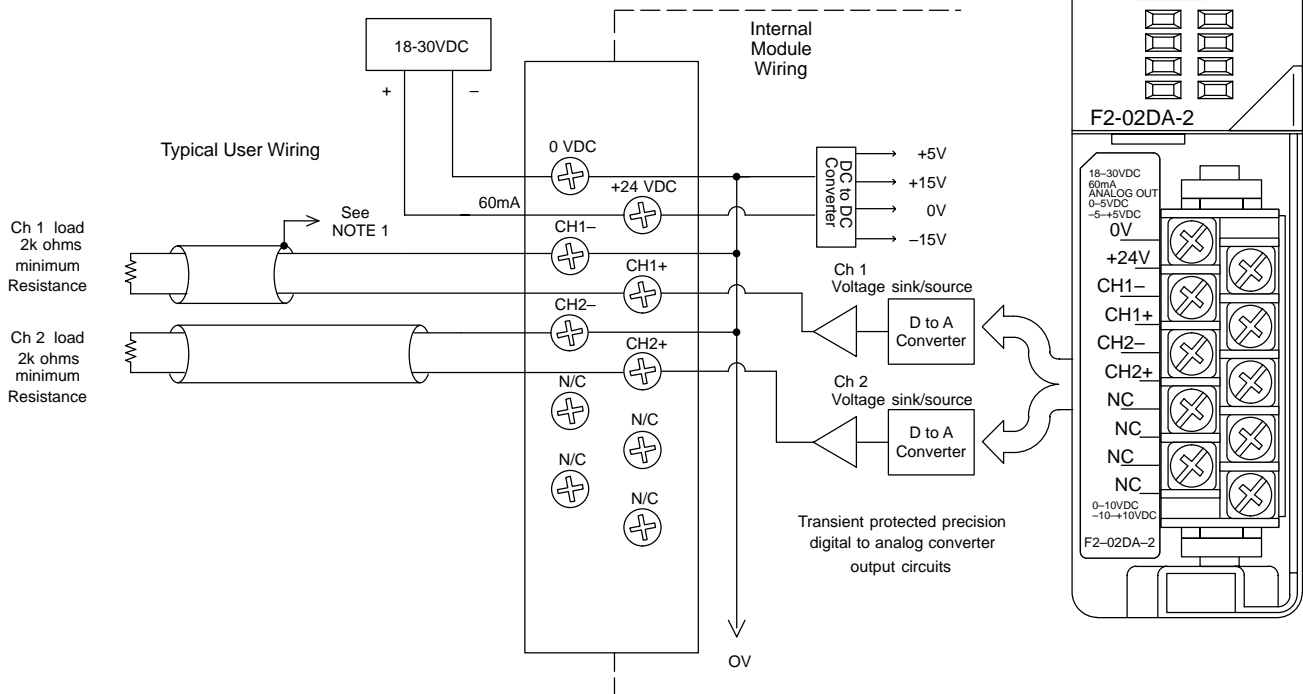

F2-02DA-2, (L)  
2-Ch. Voltage Output

## Module Operation

### Channel Update Sequence for a DL230 CPU (Multiplexing)

Before you begin writing the control program, it is important to take a few minutes to understand how the module processes and represents the analog signals.

If you are using a DL230 CPU, you can send one channel of data to the output module on each scan. The module refreshes both field devices on each scan, but you can only get new data from the CPU at the rate of one channel per scan. Since there are two channels, it can take two scans to update both channels. However, if you are only using one channel, you can update that channel on every scan. The multiplexing method can also be used for DL240/250-1/260 CPUs.

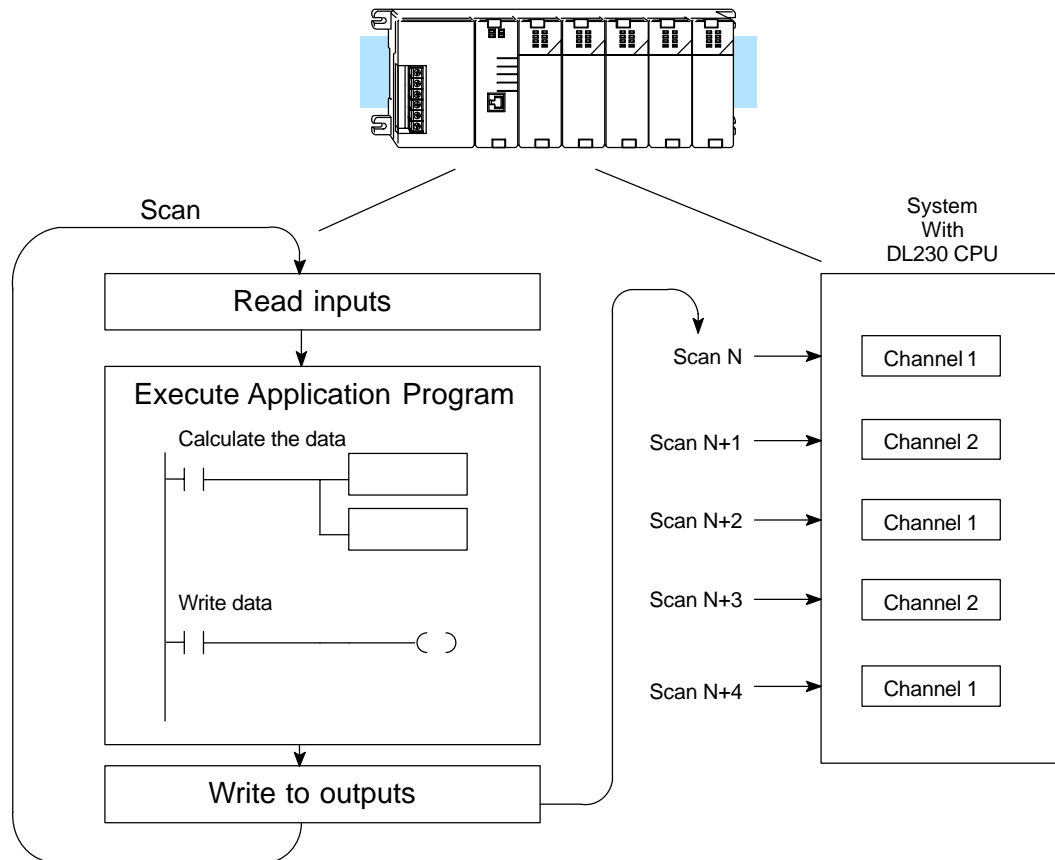

**Channel Scanning Sequence for a DL240, DL250-1 or DL260 CPU (Pointer Method)**

If you are using a DL240, DL250-1 or DL260 CPU, you can update both channels on every scan. This is because the DL240/250-1/260 CPU supports special V-memory locations that are used to manage the data transfer. This is discussed in more detail in the section on Writing the Control Program.

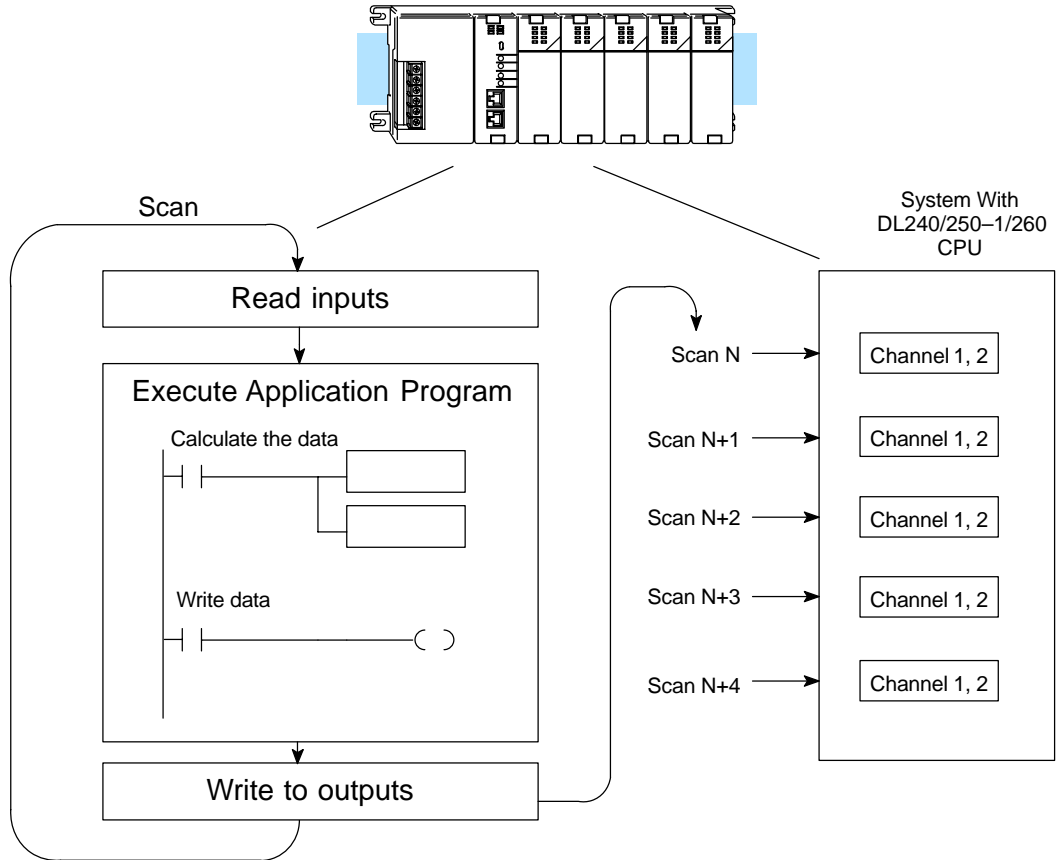

F2-02DA-2, (L)  
2-Ch. Voltage Output

**Understanding the Output Assignments**

You may recall the F2-02DA-2 (L) module requires 16 discrete output points in the CPU. These points provide the data value and an indication of which channel to update. Note, if you are using a DL240/250-1/260 CPU, you may never have to use these bits, but it may help you understand the data format.

Since all output points are automatically mapped into V-memory, it is very easy to determine the location of the data word that will be assigned to the module.

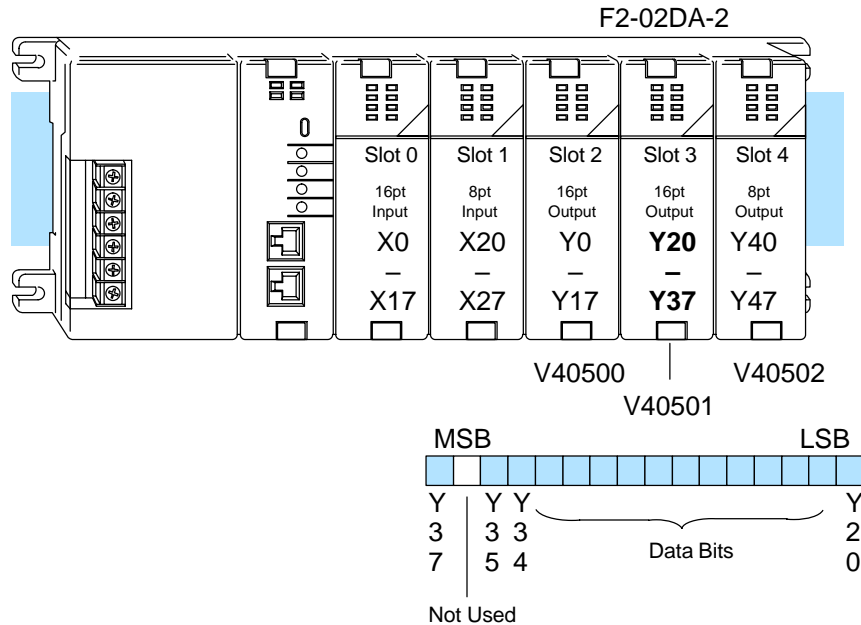

Within this word location, the individual bits represent specific information about the analog signal.

**Channel Select Outputs**

Two of the outputs select the active channel. Remember, the V-memory bits are mapped directly to discrete outputs. Turning a bit OFF selects its channel. By controlling these outputs, you can select which channel(s) gets updated.

Y35	Y34	Channel
On	Off	1
Off	On	2
Off	Off	1 & 2 (same data to both channels)
On	On	none (both channels hold current values)

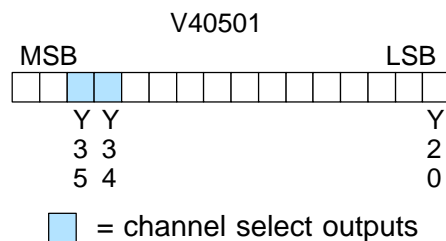

**Analog Data Bits** The first twelve bits represent the analog data in binary format.

Bit	Value	Bit	Value
0	1	6	64
1	2	7	128
2	4	8	256
3	8	9	512
4	16	10	1024
5	32	11	2048

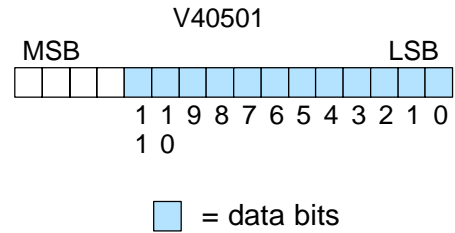

**Signal Sign Output**

The last output can be used to select the signal sign (+ or -) for bipolar ranges. By controlling this output, you can easily select positive or negative data values. Programming examples in the next section show how easy it is to make the sign selection part of your data value.

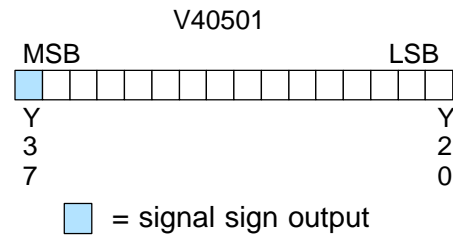

**Bipolar Output Data**

If an output channel is configured for an output format of 0 – 2047, the maximum valid value for the lower 12 bits is 2047. This means the 12'th bit (bit 11) *must* always be "0".

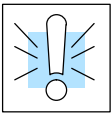
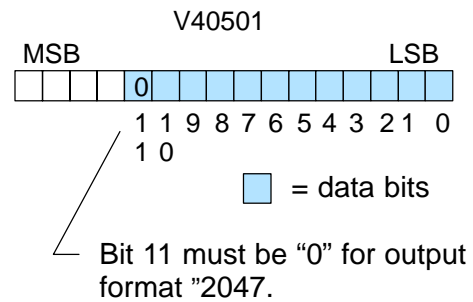

**WARNING:** If the data value exceeds 2047, the 12th bit becomes a "1", and the other eleven bits start over at "000000000000". At this point the module's channel output voltage also goes *back to the bottom of its range* and begins increasing again. The RLL program will be expecting a maximum output, but it will be minimum instead. This can have serious consequences in some applications, and may result in personal injury or damage to equipment. Therefore, in standard bipolar ranges (or whenever the output format is  $\pm 2047$  in general), be sure that your RLL program does not create numbers with absolute values greater than 2047.

**Module Resolution** Since the module has 12-bit resolution, the analog signal is converted from 4096 counts ranging from 0–4095 ( $2^{12}$ ). For example, with a 0 to 10V range, send a 0 to get a 0V signal, and send 4095 to get a 10V signal. This is equivalent to a binary value of 0000 0000 0000 to 1111 1111 1111, or 000 to FFF hexadecimal.

Each count can also be expressed in terms of the signal level by using the following equation:

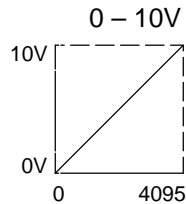

$$\text{Resolution} = \frac{H - L}{4095}$$

H = high limit of the signal range

L = low limit of the signal range

The following table shows the smallest change in signal level due to a digital value change of 1 LSB count.

Voltage Range	Signal Span	Divide By	Smallest Output Change
0 to 5V	5 volts	4095	1.22 mV
0 to 10V	10 volts	4095	2.44 mV
± 5V	10 volts	4095	2.44 mV
± 10V	20 volts	4095	4.88 mV

## Writing the Control Program

### Calculating the Digital Value

Your program has to calculate the digital value to send to the analog module. There are many ways to do this, but most applications are understood more easily if you use measurements in engineering units. This is accomplished by using the conversion formula shown.

You may have to make adjustments to the formula depending on the scale you choose for the engineering units.

$$A = U \frac{4095}{H - L} \quad \text{for 0-4095 output format}$$

$$A = U \frac{2047}{H - L} \quad \text{for 0-2047 output format}$$

A = Analog value (0 – 4095)

U = Engineering units

H = High limit of the engineering unit range

L = Low limit of the engineering unit range

Consider the following example which controls pressure from 0.0 to 99.9 PSI. By using the formula you can easily determine the digital value that should be sent to the module. The example shows the conversion required to yield 49.4 PSI. Notice the formula uses a multiplier of 10. This is because the decimal portion of 49.4 cannot be loaded, so you must adjust the formula to compensate for it.

$$A = 10U \frac{4095}{10(H - L)}$$

$$A = 494 \frac{4095}{1000 - 0}$$

$$A = 2023$$

The following example program shows how you would write the program to perform the engineering unit conversion to output data formats 0–4095. This example assumes you have calculated or loaded the engineering unit values in BCD format and stored them in V2300 and V2301 for channels 1 and 2 respectively. The DL205 offers instructions that allow you to perform math operations using BCD format. It is usually easier to perform any math calculations in BCD and then convert the value to binary before you send the data to the module.

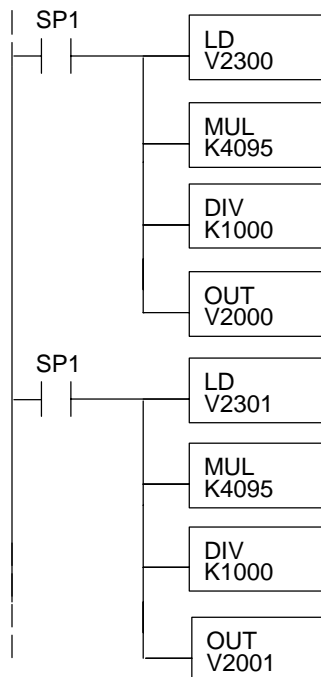

The LD instruction loads the engineering units used with channel 1 into the accumulator. This example assumes the numbers are BCD. Since SP1 is used, this rung automatically executes on every scan. You could also use an X, C, etc. permissive contact.

Multiply the accumulator by 4095 (to start the conversion).

Divide the accumulator by 1000 (because we used a multiplier of 10, we have to use 1000 instead of 100).

Store the BCD result in V2000 (the actual steps required to send the data are shown later).

The LD instruction loads the engineering units used with channel 2 into the accumulator. This example assumes the numbers are BCD. Since SP1 is used, this rung automatically executes on every scan. You could also use an X, C, etc. permissive contact.

Multiply the accumulator by 4095 (to start the conversion).

Divide the accumulator by 1000 (because we used a multiplier of 10, we have to use 1000 instead of 100).

Store the BCD result in V2001 (the actual steps required to send the data are shown later).

**Negative Values with Bipolar Range**

If you are using the bipolar ranges ( $\pm 5V$ ,  $\pm 10V$ ) or an output data format of  $\pm 2047$ , you also need to specify whether the value is positive or negative. There are two ways to show that the value is negative:

- Turn on the sign output (Y37 in the examples, DL230 only).
- Embed the sign output in the data value (required for the DL240/250-1/260 using the pointer method, an optional method for the DL230).

To embed the sign output in the data values, just OR 8000 to the value. This has the same effect as turning on Y37. Remember, the V-memory location is mapped directly to the outputs.

If you are going to use bipolar ranges, you also need to add logic to handle the positive and negative values. The logic would be similar for both values, but you should use some type of permissive contact to select the appropriate section of logic. Here is an example that re-scales a variable from a 0-1000 range to a 0-2047 range. It includes a step that combines 8000 with the value to make it negative.



**NOTE:** Do not exceed a value of 2047 for  $\pm 2047$  output formats.

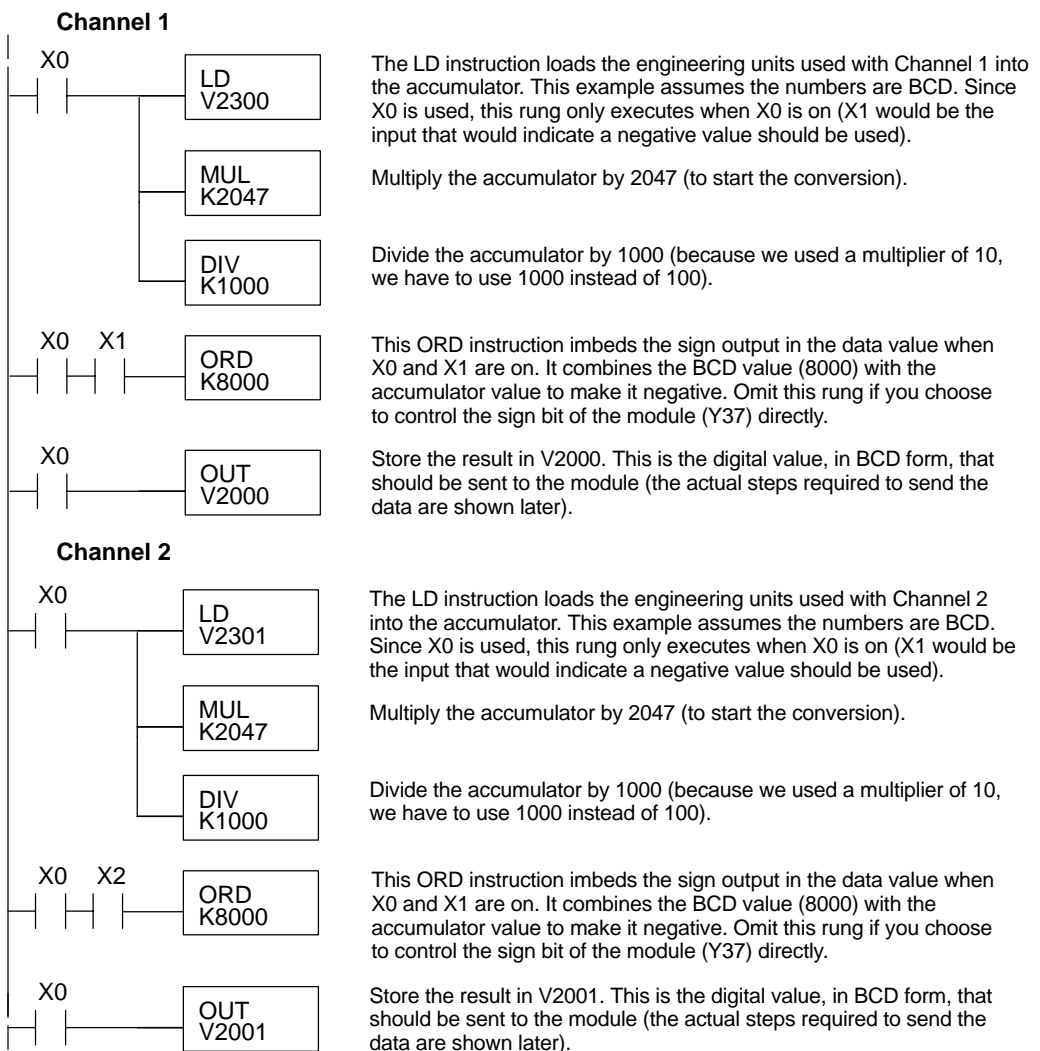

F2-02DA-2, (L)  
2-Ch. Voltage Output

### Writing Values: Pointer Method and Multiplexing

There are two methods of reading values:

- The pointer method
- Multiplexing

You *must* use the multiplexing method when using a DL230 CPU. You must also use the multiplexing method with remote I/O modules (the pointer method will not work). You can use either method when using DL240, DL250-1 and DL260 CPUs, but for ease of programming it is strongly recommended that you use the pointer method.

Once you have calculated the data values (shown previously) you must enter the program that actually updates the module. The DL240/250-1/260 has special V-memory locations assigned to each base slot that greatly simplify the programming requirements. By using these V-memory locations you can:

- specify the number of channels to update.
- specify where to obtain the output data .

### Writing Values (Pointer Method)

✗	✓	✓	✓
230	240	250-1	260



**NOTE:** DL240 CPUs with firmware release 1.5 or later supports this method. DL250 CPUs with firmware release version 1.06 or later support this method. If you must use the DL230 example, module placement in the base is very important. Review the section earlier in this chapter for guidelines.

The following program example shows how to setup these locations. Place this rung anywhere in the ladder program, or in the initial stage if you are using stage programming. You may recall in the previous example we used V2000 and V2001 to store the calculated values. Also, in the previous examples we had the analog module installed in slot 3. You should use the appropriate memory locations for your application. The pointer method automatically converts values to BCD.

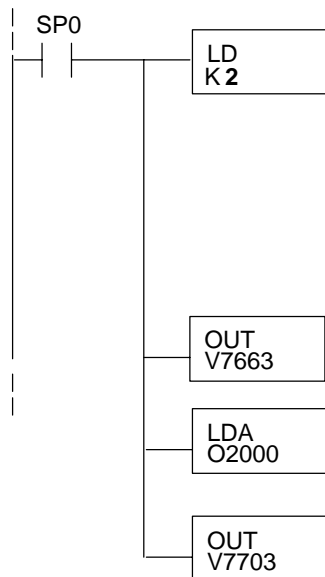

- or - LD K 82

Loads a constant that specifies the number of channels to scan and the data format. The lower byte, most significant nibble (MSN) selects the data format (0=BCD, 8=Binary), the LSN selects the number of channels (1 or 2).

The binary format is used for displaying data on some operator interfaces. The DL230/240 CPUs do not support binary math functions, whereas the DL250 does.

Special V-memory location assigned to slot 3 that contains the number of channels to scan.

This loads an octal value for the first V-memory location that will be used to store the output data. For example, the O2000 entered here would designate the following addresses:  
Ch1 - V2000, Ch 2 - V2001

The octal address (O2000) is stored here. V7703 is assigned to slot 3 and acts as a pointer, which means the CPU will use the octal value in this location to determine exactly where to store the output data.

The tables below show the special V-memory locations used by the DL240, DL250-1 and DL260 for the CPU base and local expansion base I/O slots. Slot 0 (zero) is the module next to the CPU or D2-CM module. Slot 1 is the module two places from the CPU or D2-CM, and so on. Remember, the CPU only examines the pointer values at these locations after a mode transition. Also, if you use the DL230 (multiplexing) method, verify that these addresses in the CPU are zero.

The Table below applies to the DL240, DL250-1 and DL260 CPU base.

CPU Base: Analog Output Module Slot-Dependent V-memory Locations								
Slot	0	1	2	3	4	5	6	7
No. of Channels	V7660	V7661	V7662	V7663	V7664	V7665	V7666	V7667
Storage Pointer	V7700	V7701	V7702	V7703	V7704	V7705	V7706	V7707

The Table below applies to the DL250-1 or DL260 expansion base 1.

Expansion Base D2-CM #1: Analog Output Module Slot-Dependent V-memory Locations								
Slot	0	1	2	3	4	5	6	7
No. of Channels	V36000	V36001	V36002	V36003	V36004	V36005	V36006	V36007
Storage Pointer	V36020	V36021	V36022	V36023	V36024	V36025	V36026	V36027

The Table below applies to the DL250-1 or DL260 expansion base 2.

Expansion Base D2-CM #2: Analog Output Module Slot-Dependent V-memory Locations								
Slot	0	1	2	3	4	5	6	7
No. of Channels	V36100	V36101	V36102	V36103	V36104	V36105	V36106	V36107
Storage Pointer	V36120	V36121	V36122	V36123	V36124	V36125	V36126	V36127

The Table below applies to the DL260 CPU expansion base 3.

Expansion Base D2-CM #3: Analog Output Module Slot-Dependent V-memory Locations								
Slot	0	1	2	3	4	5	6	7
No. of Channels	V36200	V36201	V36202	V36203	V36204	V36205	V36206	V36207
Storage Pointer	V36220	V36221	V36222	V36223	V36224	V36225	V36226	V36227

The Table below applies to the DL260 CPU expansion base 4.

Expansion Base D2-CM #4: Analog Output Module Slot-Dependent V-memory Locations								
Slot	0	1	2	3	4	5	6	7
No. of Channels	V36300	V36301	V36302	V36303	V36304	V36305	V36306	V36307
Storage Pointer	V36320	V36321	V36322	V36323	V36324	V36325	V36326	V36327

### Writing Data (Multiplexing)

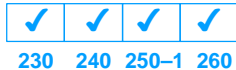

The DL230 CPU *does not* have the special V-memory locations that allow you to automatically enable the data transfer. Since all channels are multiplexed into a single data word, the control program must be set up to determine which channel to write. Since the module appears as Y output points to the CPU, it is very easy to use the channel selection outputs to determine which channel to update.

Note, this example is for a module installed as shown in the previous examples. The addresses used would be different if the module was used in a different I/O arrangement. You can place these rungs anywhere in the program or if you are using stage programming, place them in a stage that is always active.

This example is a two-channel multiplexer that updates each channel on alternate scans. SP7 is a special relay that is on for one scan then off for one scan. A permissive contact on the last rung handles an embedded sign bit.



**NOTE:** You must send binary data to the module. If the data is already in binary format, you should not use the BIN instruction shown in this example.

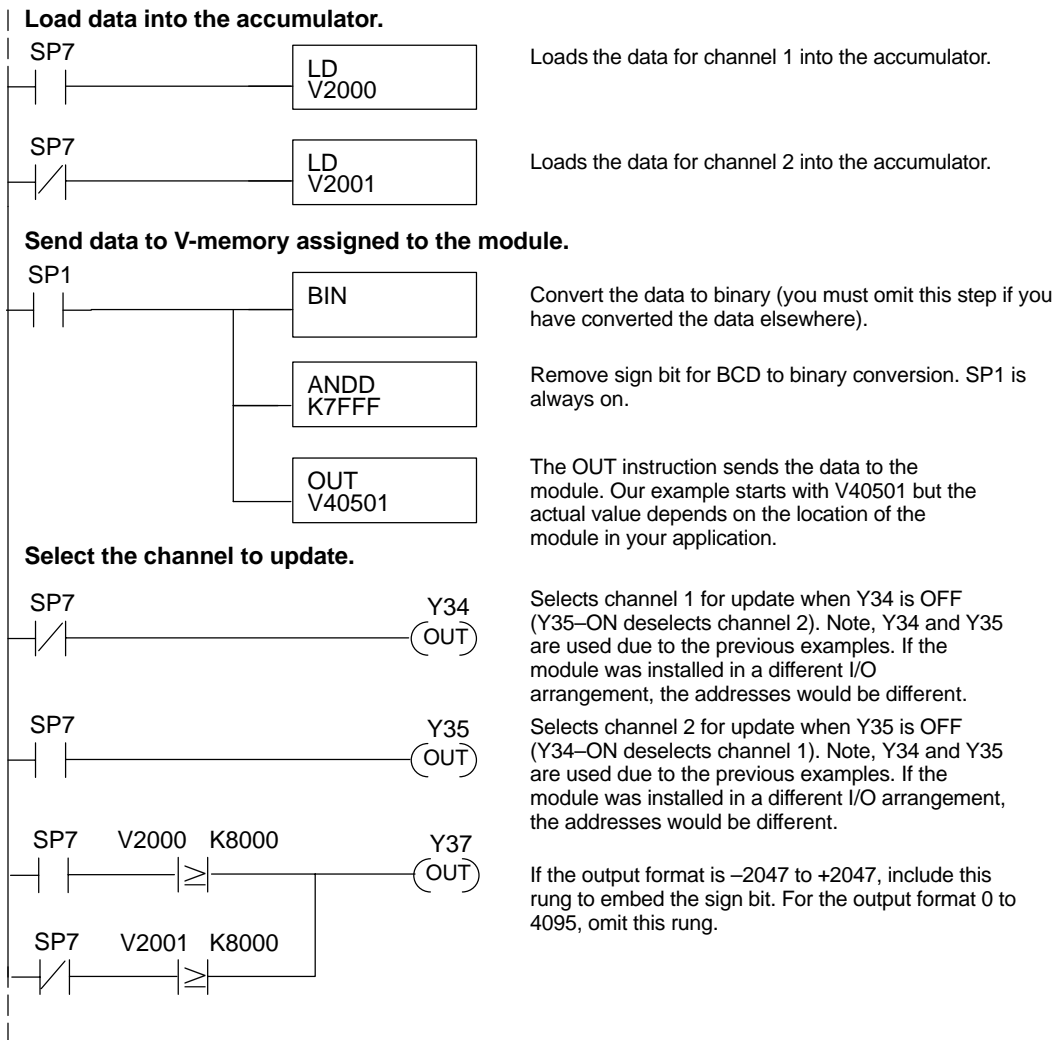

If you are using an output format range of  $\pm 2047$  (most commonly used with bipolar voltage ranges), you also must specify whether the values are positive or negative. You could use the previous example with a simple addition to activate the sign output bit, or the following example uses individual contacts to determine the sign bit status for each channel.



**NOTE:** If you embed the sign information into the data value (by adding 8000 to the data value) you should not use this method. Use the previous example.

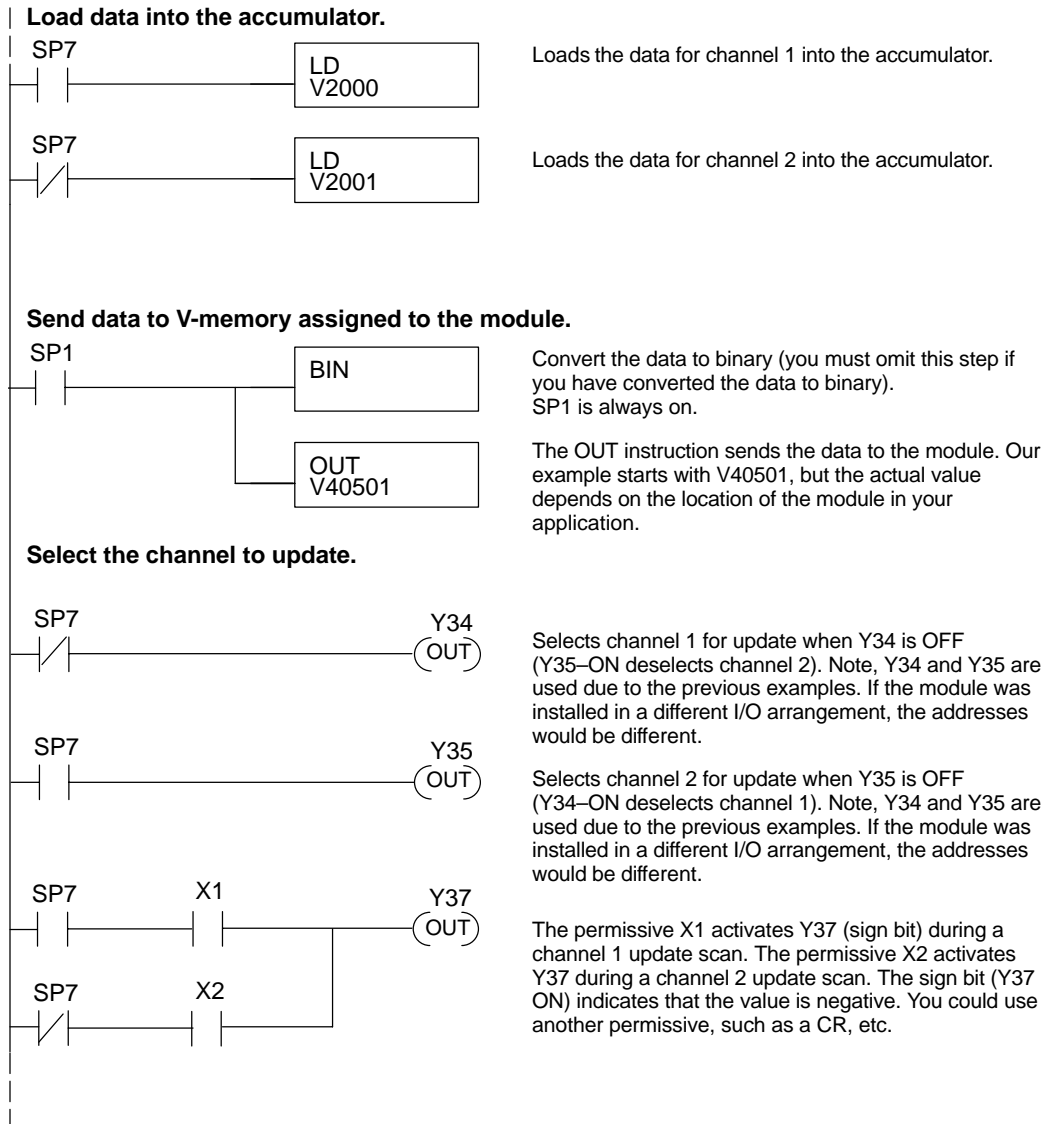

F2-02DA-2, (L)  
2-Ch. Voltage Output

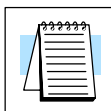

**NOTE:** Do not exceed a value of 2047 for  $\pm 2047$  output data formats.

**Sending Data to One Channel**

If you are not using both channels, or if you want to control the updates separately, use the following program. Remember, for bipolar ranges you either have to embed the sign information or use the sign output bit.

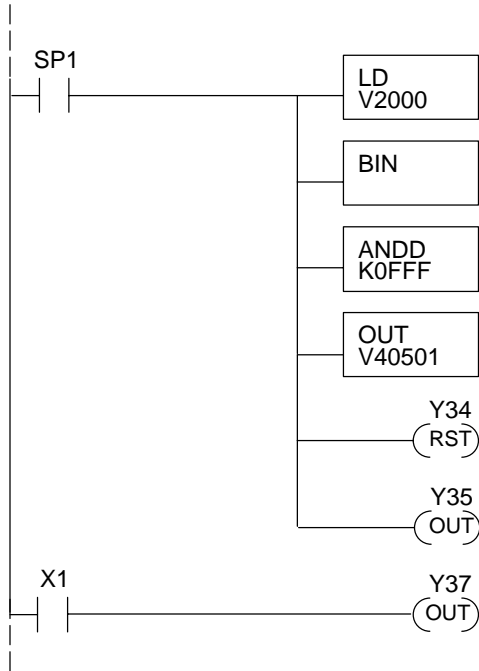

The LD instruction loads the data into the accumulator. Since SP1 is used, this rung automatically executes on every scan. You could also use an X, C, etc. permissive contact.

The BIN instruction converts the accumulator data to binary (you must omit this step if you have already converted the data elsewhere).

The ANDD instruction masks off the channel select bits to prevent an accidental channel selection.

The OUT instruction sends the data to the module. Our example starts with V40501, but the actual value depends on the location of the module in your application.

Y34-OFF selects channel 1 for updating.

Y35-ON deselects channel 2 (do not update).

The permissive X1 activates Y37, which is the sign bit. The sign bit indicates that the value is negative. You could use another permissive, such as a CR, etc. Omit this rung if you are using the 0 to +4095 output format.

**Sending the Same Data to Both Channels**

If both channel selection outputs are off, both channels will be updated with the same data. Remember, for bipolar ranges you either have to embed the sign information or use the sign output bit.

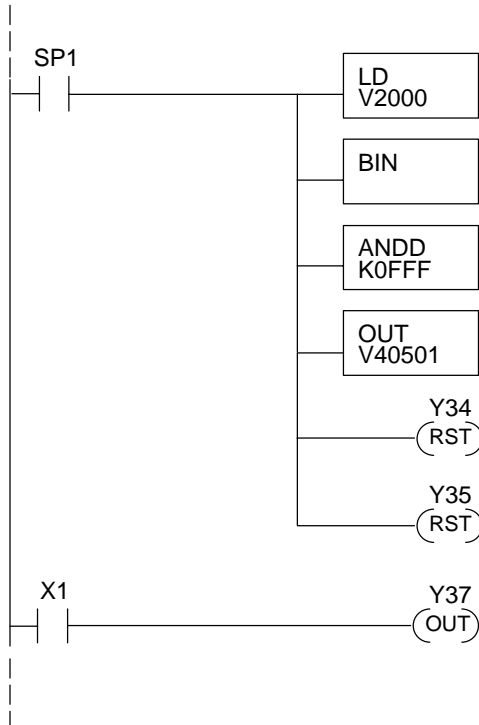

The LD instruction loads the data into the accumulator. Since SP1 is used, this rung automatically executes on every scan. You could also use an X, C, etc. permissive contact.

The BIN instruction converts the accumulator data to binary (you must omit this step if you have already converted the data elsewhere).

The ANDD instruction masks off the channel select bits to prevent an accidental channel selection.

The OUT instruction sends the data to the module. Our example starts with V40501, but the actual value depends on the location of the module in your application.

Y34-OFF selects channel 1 for updating.

Y35-OFF selects channel 2 for updating.

The permissive X1 activates Y37, which is the sign bit. The sign bit indicates that the value is negative. You could use another permissive, such as a CR, etc. Omit this rung if you are using the 0 to +4095 output format.

F2-02DA-2, (L)  
2-Ch. Voltage Output

## Analog and Digital Value Conversions

Sometimes it is useful to be able to quickly convert between the signal levels and the digital values. This is especially helpful during machine startup or troubleshooting. The following table provides formulas to make this conversion easier. Remember, if you embed the sign information into the data value, you must adjust the formulas accordingly.

Range	If you know the digital value ...	If you know the signal level ...
0 to 10V	$A = \frac{10D}{4095}$	$D = \frac{4095}{10} (A)$
± 10V (output format ± 2047)	$A = \frac{10D}{2047}$	$D = \frac{2047}{10} (A)$
0 to 5V	$A = \frac{5D}{4095}$	$D = \frac{4095}{5} (A)$
± 5V (output format ± 2047)	$A = \frac{5D}{2047}$	$D = \frac{2047}{5} (A)$

For example, if you are using the ±10V range with an output format of ±2047, and you know you need a 6V signal level, use this formula to determine the digital value (D) that will be stored in the V-memory location that contains the data.

$$D = \frac{2047}{10} (A)$$

$$D = \frac{2047}{10} (6V)$$

$$D = (204.7) (6)$$

$$D = 1228$$

# F2-08DA-1

## 8-Channel Analog Current Output

---

In This Chapter. . . .

- Module Specifications
  - Setting the Module Jumper
  - Connecting the Field Wiring
  - Module Operation
  - Writing the Control Program
-

## Module Specifications

The F2-08DA-1 Analog Input module provides several hardware features:

- Supports DL230, DL240, DL250-1 and DL260 CPUs (see firmware requirements below).
- Analog outputs are optically isolated from the PLC logic.
- The module has a removable terminal block, so the module can be easily removed or changed without disconnecting the wiring.
- Can update all channels in one scan (DL240, DL250-1 and DL260 only).
- Outputs are both current sinking and sourcing.

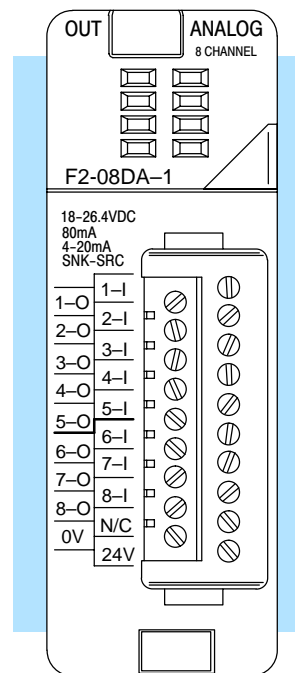

F2-08DA-1

### Firmware Requirements:

To use this module, DL230 CPUs must have firmware version 2.7 or later. To use the pointer method of writing values, DL240 CPUs require firmware version 3.0 or later and DL250 CPUs require firmware version 1.33 or later.

The following tables provide the specifications for the F2-08DA-1 Analog Output Module. Review these specifications to make sure the module meets your application requirements.

### Output Specifications

Number of Channels	8, single-ended
Output Range	4–20mA
Resolution	12 bit (1 in 4096)
Output Type	Current sinking and current sourcing
Maximum Loop Voltage	30VDC
Source Load	0Ω – 400Ω (for loop power 18 – 30V)
Sink Load	0 – 600Ω/18V, 0–900Ω/24V, 0–1200Ω/30V
Total Load (sink plus source)	600Ω/18V, 900Ω/24V, 1200Ω/30V
Linearity Error (end to end)	± 2 count ( ± 0.050% of full scale) maximum
Conversion Settling Time	400μs maximum (full scale change)
Full-Scale Calibration Error	± 12 counts max. sinking (any load) ± 12 counts max. sourcing (125Ω load) ± 18 counts max. sourcing (250Ω load) ± 26 counts max. sourcing (400Ω load)
Offset Calibration Error	± 9 counts max. sinking (any load) ± 9 counts max. sourcing (125Ω load) ± 11 counts max. sourcing (250Ω load) ± 13 counts max. sourcing (400Ω load)
Max. Full Scale Inaccuracy @ 60°C	0.5% sinking (any load) & sourcing (125Ω load) 0.64% sourcing (250Ω load) 0.83% sourcing (400Ω load)
Max. Full Scale Inaccuracy @ 25°C (includes all errors & temperature drift)	0.3% sinking (any load) & sourcing (125Ω load) 0.44% sourcing (250Ω load) 0.63% sourcing (400Ω load)

### General Specifications

PLC Update Rate	8 channels per scan maximum
Digital Outputs / Output Points Required	12 binary data bits, 3 ch. ID bits, 1 output enable bit / 16 (Y) output points required
Power Budget Requirement	30mA @ 5VDC (supplied by base)
External Power Supply	18–30VDC, 50mA plus 20mA/output loop, class 2
Operating Temperature	0 to 60° C (32 to 140° F)
Storage Temperature	–20 to 70° C (–4 to 158° F)
Relative Humidity	5 to 95% (non-condensing)
Environmental Air	No corrosive gases permitted
Vibration	MIL STD 810C 514.2
Shock	MIL STD 810C 516.2
Noise Immunity	NEMA ICS3–304

One count in the specification table is equal to one least significant bit of the analog data value (1 in 4096).

### Analog Output Configuration Requirements

The F2-08DA-1 analog output requires 16 discrete output points. The module can be installed in any slot of a DL205 system, but the available power budget and discrete I/O points can be limiting factors. Check the user manual for your particular model of CPU and I/O base for more information regarding power budget and number of local, local expansion or remote I/O points.

### Special Placement Requirements (DL230 and Remote I/O Bases)

Even though the module can be placed in any slot, it is important to examine the configuration. As you can see in the section on writing the program, you use V-memory locations to extract the analog data. If you place the module so the output points do not start on a V-memory boundary, the instructions cannot access the data. This also applies when module is placed in remote base (D2-RSSS in CPU slot).

#### Correct!

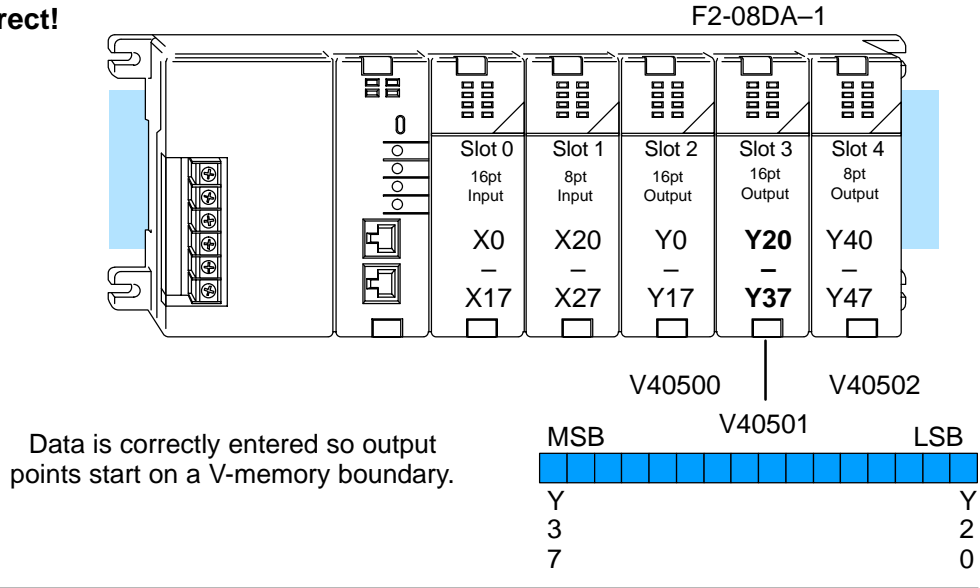

#### Incorrect

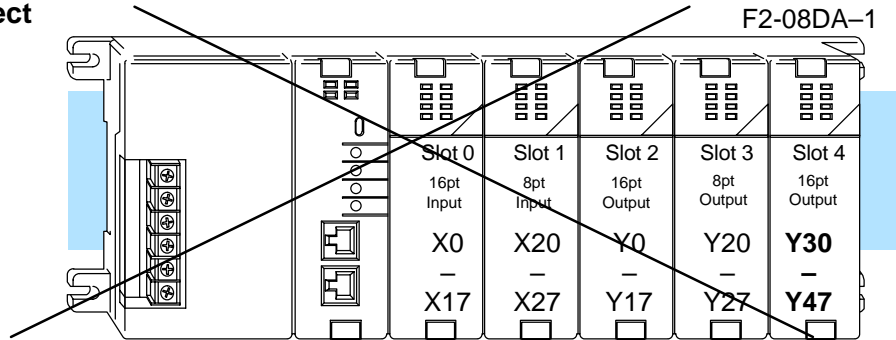

To use the V-memory references required for the multiplexing method, the first output address assigned to the module must be one of the following Y locations. The table also shows the V-memory addresses that correspond to these Y locations.

Y	Y0	Y20	Y40	Y60	Y100	Y120	Y140	Y160
V	V40500	V40501	V40502	V40503	V40504	V40505	V40506	V40507

## Connecting the Field Wiring

### Wiring Guidelines

Your company may have guidelines for wiring and cable installation. If so, you should check those before you begin the installation. Here are some general things to consider:

- Use the shortest wiring route whenever possible.
- Use shielded wiring and ground the shield at the signal source. *Do not* ground the shield at both the module and the load.
- Do not run the signal wiring next to large motors, high current switches, or transformers. This may cause noise problems.
- Route the wiring through an approved cable housing to minimize the risk of accidental damage. Check local and national codes to choose the correct method for your application.

### User Power Supply Requirements

The F2-08DA-1 requires a separate field-side power supply. Each module requires 18–30VDC at up to 50mA current. The current loops also require 18–30VDC, but at 20mA each.

The DL205 bases have built-in 24 VDC power supplies that provide up to 300mA of current. If you are using only a couple of analog modules, you can use this power source instead of a separate supply. The current required is 50mA plus 160mA (eight loops) for a total of 210mA.

It is desirable in some situations to power the loops separately in a location remote from the PLC. This will work as long as the loop supply meets the voltage and current requirements, and the transmitter's minus (–) side and the module supply's minus (–) side are connected together.

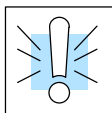

**WARNING:** If you are using 24VDC output power from the base, make sure you calculate the power budget. Exceeding the power budget can cause unpredictable system operation that can lead to a risk of personal injury or damage to equipment.

### Wiring Diagram

The F2-08DA-1 module has a removable connector to make wiring easier. Squeeze the latches on both ends of the connector and gently pull it from the module. Use the following diagram to connect the field wiring. Channels 1 and 2 are shown wired for sourcing, and channels 7 and 8 are shown wired for sinking. The diagram also shows how to wire an optional loop power supply.

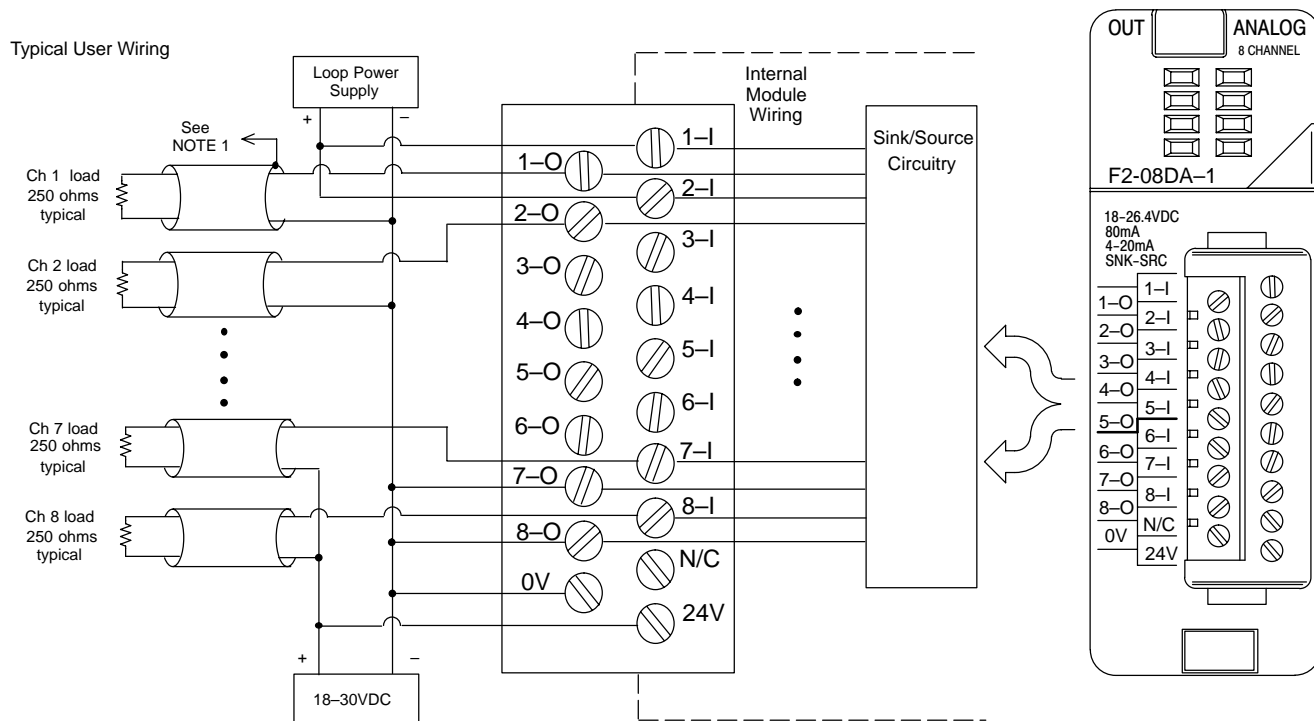

NOTE 1: Shields should be connected to the 0V terminal of the module.

### Load Range

The maximum load resistance depends on the particular loop power supply in use.

Loop Power Supply Voltage	Source Load Range	Sink Load Range
30 VDC	0 to 400Ω	0 to 1200Ω
24 VDC		0 to 900Ω
18 VDC		0 to 600Ω

## Module Operation

### Channel Update Sequence for a DL230 CPU (Multiplexing)

Before you begin writing the control program, it is important to take a few minutes to understand how the module processes and represents the analog signals.

If you are using multiplexing ladder, you can send one channel of data to the output module on each scan. The module refreshes both field devices on each scan, but you can only get new data from the CPU at the rate of one channel per scan. Since there are eight channels, it can take eight scans to update all channels. However, if you are only using one channel, you can update that channel on every scan. The multiplexing method can also be used for the DL240/250-1/260 CPUs.

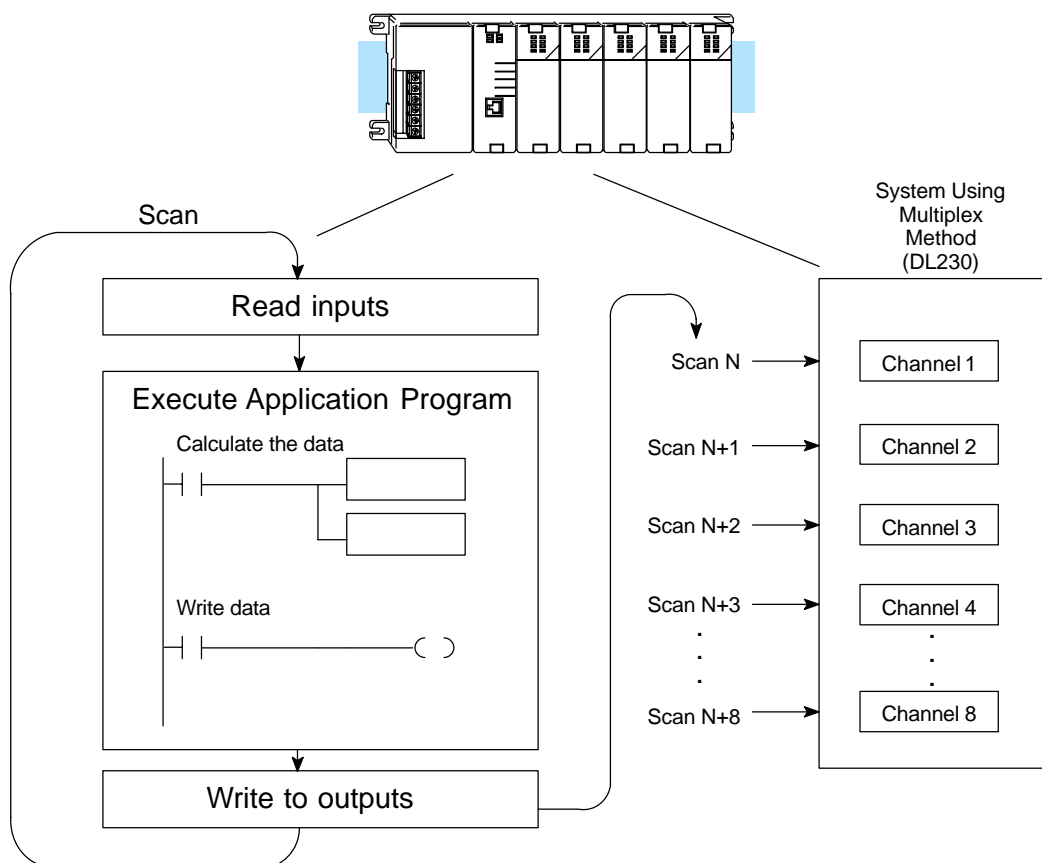

**Channel Scanning Sequence with a DL240, DL250-1 or DL260 CPU (Multiplexing)**

If you are using pointers (Pointer Method), you can update all channels on every scan. This is because the DL240/250-1/260 CPU supports special V-memory locations that are used to manage the data transfer. This is discussed in more detail in the section on Writing the Control Program.

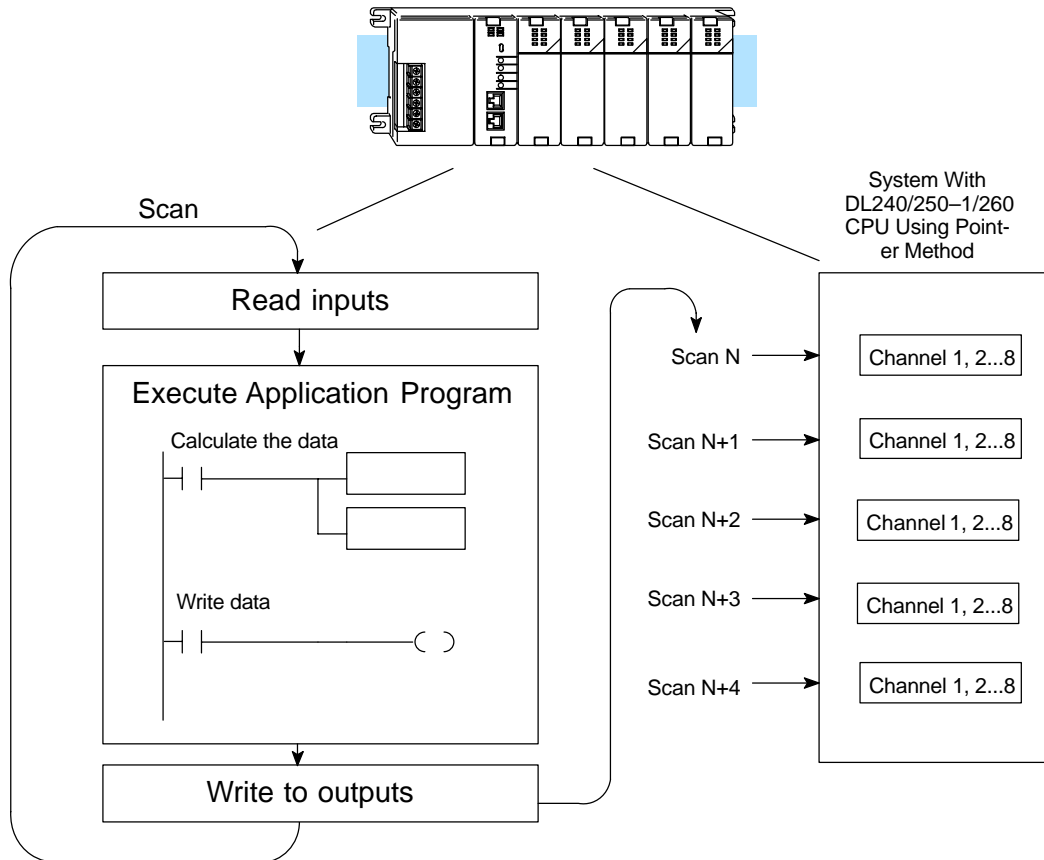

**Understanding the Output Assignments**

You may recall the F2-08DA-1 module requires 16 discrete output points in the CPU. These points provide the data value and an indication of which channel to update. Note, if you are using a DL240/250-1/260 CPU, you may never have to use these bits, but it may help you understand the data format.

Since all output points are automatically mapped into V-memory, it is very easy to determine the location of the data word that will be assigned to the module.

F2-08DA-1 8-Channel Analog Current Output

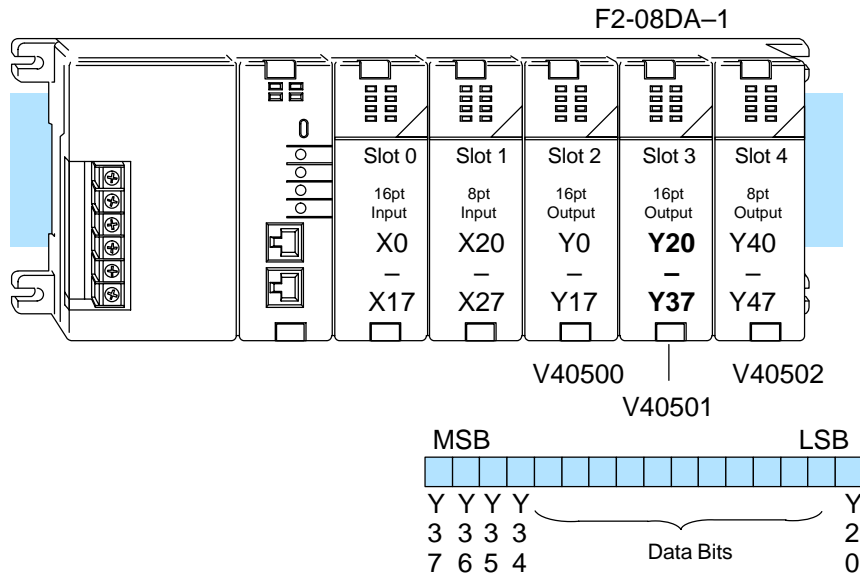

Within this word location, the individual bits represent specific information about the analog signal.

**Channel Select Outputs**

Three of the outputs select the active channel. Remember, the V-memory bits are mapped directly to discrete outputs. The binary weight of these three bits determines the selected channel. By controlling these outputs, you can select which channel gets updated.

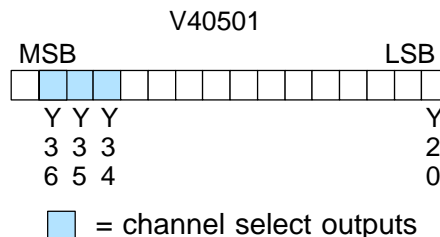

Y36	Y35	Y34	Channel Number Selected
			1
		X	2
	X		3
	X	X	4
X			5
X		X	6
X	X		7
X	X	X	8

**Analog Data Bits** The first twelve bits represent the analog data in binary format.

Bit	Value	Bit	Value
0	1	6	64
1	2	7	128
2	4	8	256
3	8	9	512
4	16	10	1024
5	32	11	2048

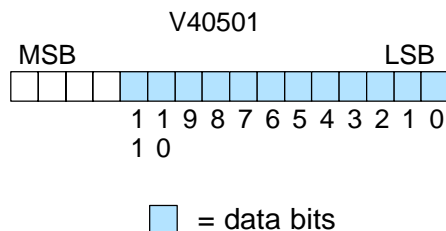

**Output Enable** The last output can be used to update outputs. If this output is off the outputs are cleared.

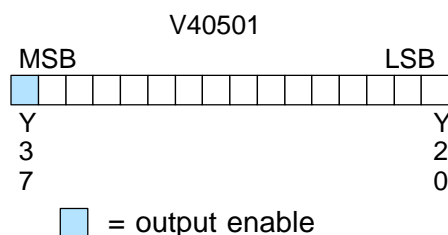

**Module Resolution** Since the module has 12-bit resolution, the analog signal is converted from 4096 counts ranging from 0–4095 ( $2^{12}$ ). For example, send a 0 to get a 4mA signal, and send 4095 to get a 20mA signal. This is equivalent to a binary value of 0000 0000 0000 to 1111 1111 1111, or 000 to FFF hexadecimal.

Each count can also be expressed in terms of the signal level by using the following equation:

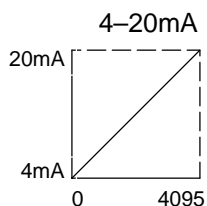

$$\text{Resolution} = \frac{H - L}{4095}$$

H = high limit of the signal range

L = low limit of the signal range

## Writing the Control Program

### Calculating the Digital Value

Your program has to calculate the digital value to send to the analog module. There are many ways to do this, but most applications are understood more easily if you use measurements in engineering units. This is accomplished by using the conversion formula shown.

You may have to make adjustments to the formula depending on the scale you choose for the engineering units.

$$A = U \frac{4095}{H - L} \quad \text{for 0-4095 output format}$$

A = Analog value (0 – 4095)

U = Engineering units

H = High limit of the engineering unit range

L = Low limit of the engineering unit range

Consider the following example which controls pressure from 0.0 to 99.9 PSI. By using the formula you can easily determine the digital value that should be sent to the module. The example shows the conversion required to yield 49.4 PSI. Notice the formula uses a multiplier of 10. This is because the decimal portion of 49.4 cannot be loaded, so you must adjust the formula to compensate for it.

$$A = 10U \frac{4095}{10(H - L)}$$

$$A = 494 \frac{4095}{1000 - 0}$$

$$A = 2023$$

The following example program shows how you would write the program to perform the engineering unit conversion to output data formats 0-4095. This example assumes you have calculated or loaded the engineering unit values in BCD format and stored them in V2300 and V2301 for channels 1 and 2 respectively. The DL205 offers instructions that allow you to perform math operations using BCD format. It is usually easier to perform any math calculations in BCD and then convert the value to binary before you send the data to the module.

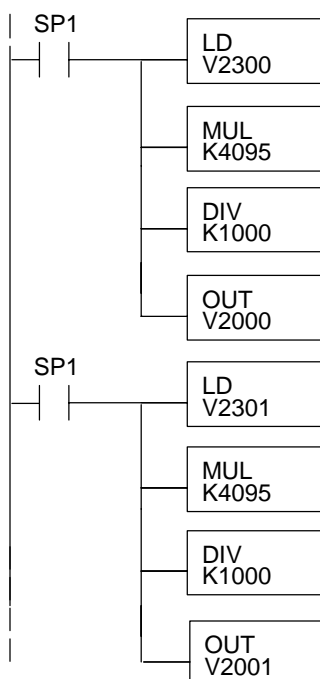

The LD instruction loads the engineering units used with channel 1 into the accumulator. This example assumes the numbers are BCD. Since SP1 is used, this rung automatically executes on every scan. You could also use an X, C, etc. permissive contact.

Multiply the accumulator by 4095 (to start the conversion).

Divide the accumulator by 1000 (because we used a multiplier of 10, we have to use 1000 instead of 100).

Store the BCD result in V2000 (the actual steps required to send the data are shown later).

The LD instruction loads the engineering units used with channel 2 into the accumulator. This example assumes the numbers are BCD. Since SP1 is used, this rung automatically executes on every scan. You could also use an X, C, etc. permissive contact.

Multiply the accumulator by 4095 (to start the conversion).

Divide the accumulator by 1000 (because we used a multiplier of 10, we have to use 1000 instead of 100).

Store the BCD result in V2001 (the actual steps required to send the data are shown later).

### Writing Values: Pointer Method and Multiplexing

There are two methods of reading values:

- The pointer method
- Multiplexing method

You can use either method when using DL240, DL250-1 and DL260 CPUs, but for ease of programming it is strongly recommended that you use the pointer method. You must use the multiplexing method when using DL230 CPUs and with remote I/O modules (the pointer method will not work).

### Pointer Method Example

✗	✓	✓	✓
230	240	250-1	260



Once you have calculated the data values (shown previously) you must enter the program that actually updates the module. The DL240/250-1/260 has special V-memory locations assigned to each base slot that greatly simplify the programming requirements. By using these V-memory locations you can:

- specify the number of channels to update.
- specify where to obtain the output data .

**NOTE:** DL240 CPUs with firmware release version 3.0 or later and DL250 CPUs with firmware release 1.33 are required to support this method.

The following program example shows how to setup these locations. Place this rung anywhere in the ladder program, or in the initial stage if you are using stage programming. You may recall in the previous example we used V2000 through V2007 to store the calculated values. Also, in the previous examples we had the analog module installed in slot 3. You should use the appropriate memory locations for your application. The pointer method automatically converts values to binary.

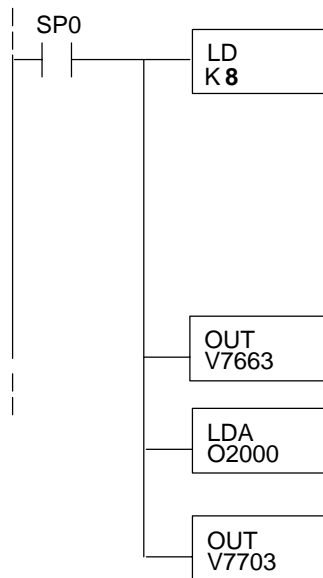

- or - LD K88

Loads a constant that specifies the number of channels to scan and the data format. The lower byte, most significant nibble (MSN) selects the data format (0=BCD, 8=Binary), the LSN selects the number of channels (1-8).

The binary format is used for displaying data on some operator interfaces. The DL230/240 CPUs do not support binary math functions, whereas the DL250-1/DL260 does.

Special V-memory location assigned to slot 3 that contains the number of channels to scan.

This loads an octal value for the first V-memory location that will be used to store the output data. For example, the O2000 entered here would designate the following addresses:  
Ch1 - V2000, Ch 2 - V2001.....Ch8 - V2007

The octal address (O2000) is stored here. V7703 is assigned to slot 3 and acts as a pointer, which means the CPU will use the octal value in this location to determine exactly where to store the output data.

The tables below show the special V-memory locations used by the DL240, DL250–1 and DL260 for the CPU base and local expansion base I/O slots. Slot 0 (zero) is the module next to the CPU or D2–CM module. Slot 1 is the module two places from the CPU or D2–CM, and so on. Remember, the CPU only examines the pointer values at these locations after a mode transition. Also, if you use the DL230 (multiplexing) method, verify that these addresses in the CPU are zero.

The Table below applies to the DL240, DL250–1 and DL260 CPU base.

CPU Base: Analog Output Module Slot-Dependent V-memory Locations								
Slot	0	1	2	3	4	5	6	7
No. of Channels	V7660	V7661	V7662	V7663	V7664	V7665	V7666	V7667
Storage Pointer	V7700	V7701	V7702	V7703	V7704	V7705	V7706	V7707

The Table below applies to the DL250–1 or DL260 expansion base 1.

Expansion Base D2–CM #1: Analog Output Module Slot-Dependent V-memory Locations								
Slot	0	1	2	3	4	5	6	7
No. of Channels	V36000	V36001	V36002	V36003	V36004	V36005	V36006	V36007
Storage Pointer	V36020	V36021	V36022	V36023	V36024	V36025	V36026	V36027

The Table below applies to the DL250–1 or DL260 expansion base 2.

Expansion Base D2–CM #2: Analog Output Module Slot-Dependent V-memory Locations								
Slot	0	1	2	3	4	5	6	7
No. of Channels	V36100	V36101	V36102	V36103	V36104	V36105	V36106	V36107
Storage Pointer	V36120	V36121	V36122	V36123	V36124	V36125	V36126	V36127

The Table below applies to the DL260 CPU expansion base 3.

Expansion Base D2–CM #3: Analog Output Module Slot-Dependent V-memory Locations								
Slot	0	1	2	3	4	5	6	7
No. of Channels	V36200	V36201	V36202	V36203	V36204	V36205	V36206	V36207
Storage Pointer	V36220	V36221	V36222	V36223	V36224	V36225	V36226	V36227

The Table below applies to the DL260 CPU expansion base 4.

Expansion Base D2–CM #4: Analog Output Module Slot-Dependent V-memory Locations								
Slot	0	1	2	3	4	5	6	7
No. of Channels	V36300	V36301	V36302	V36303	V36304	V36305	V36306	V36307
Storage Pointer	V36320	V36321	V36322	V36323	V36324	V36325	V36326	V36327

### Writing Data (Multiplexing)

✓	✓	✓	✓
230	240	250-1	260

The following example shows how to write data using the mutliplexing method.

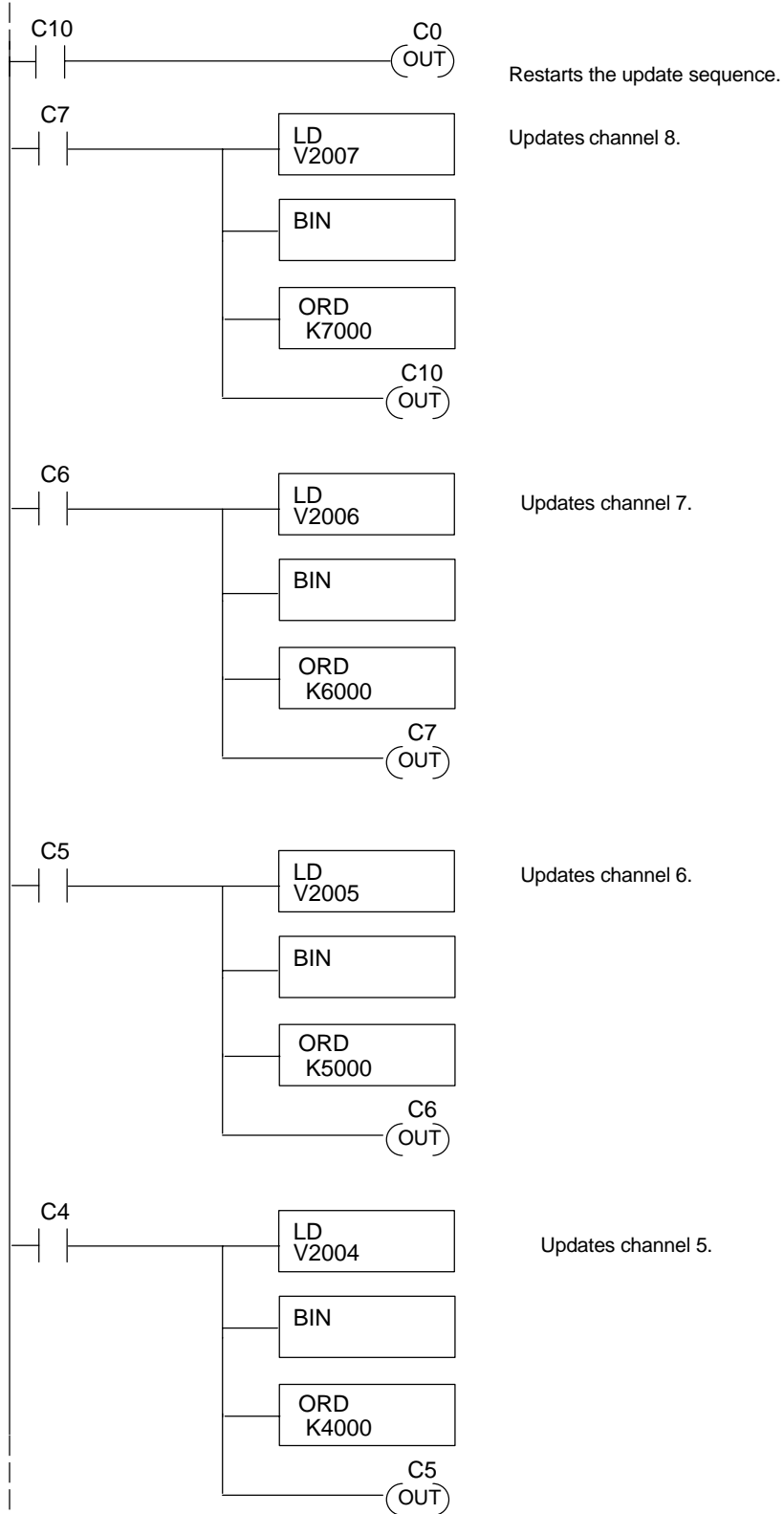

Continued

Writing Data  
(Multiplexing  
Example)  
Continued

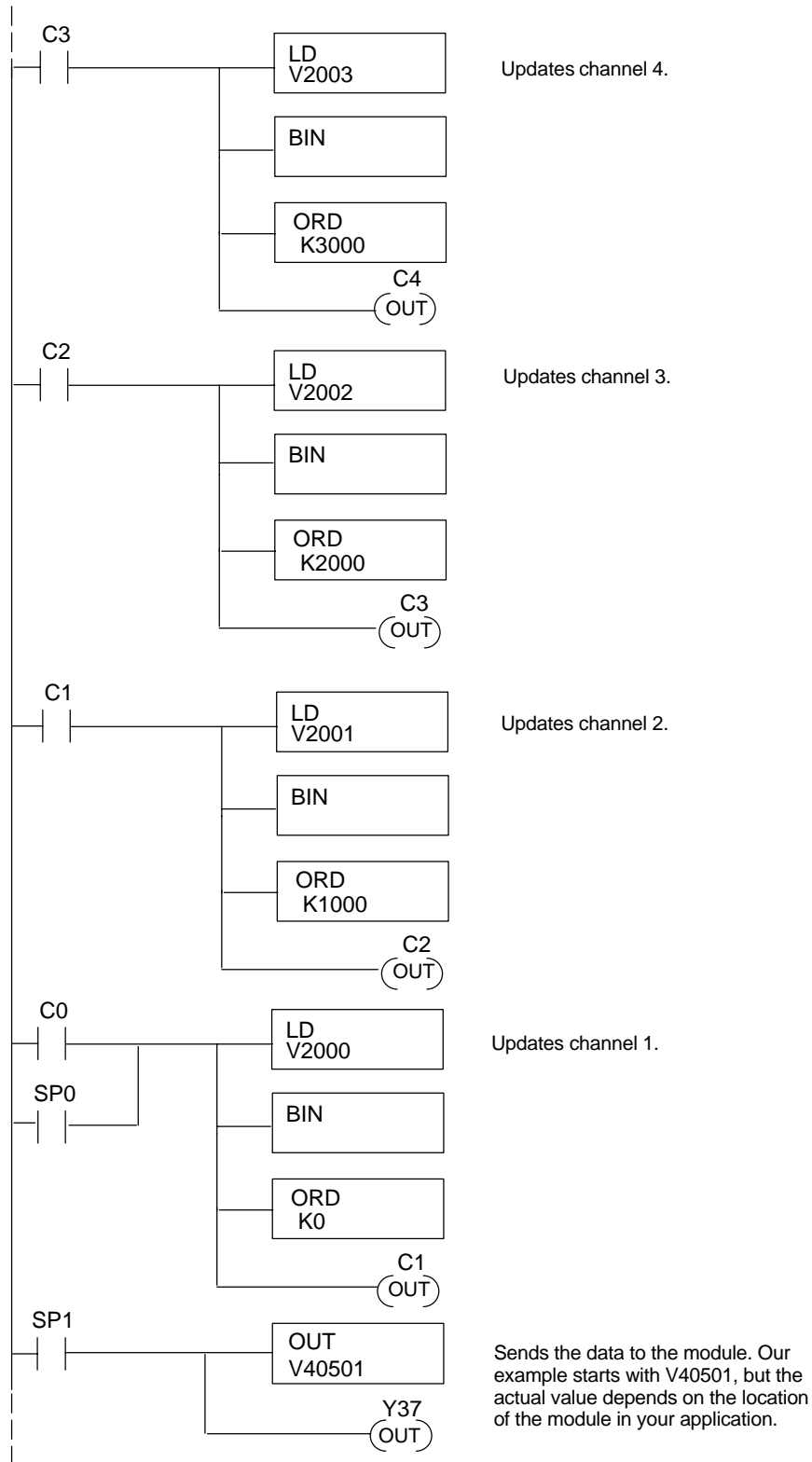

F2-08DA-1  
8-Ch. Current Output

### Sending Data to One Channel

If you are using more than one channel, or if you want to control the updates separately, use the following program.

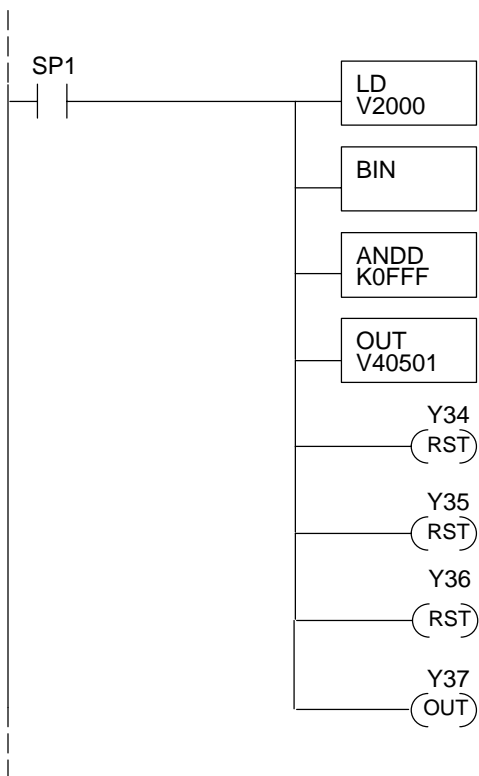

The LD instruction loads the data into the accumulator. Since SP1 is used, this rung automatically executes on every scan. You could also use an X, C, etc. permissive contact.

The BIN instruction converts the accumulator data to binary (you must omit this step if you have already converted the data elsewhere).

The ANDD instruction masks off the channel select bits to prevent an accidental channel selection.

The OUT instruction sends the data to the module. Our example starts with V40501, but the actual value depends on the location of the module in your application.

Y34, Y35, Y36-OFF selects channel 1 for updating.

Y37 is the output enable bit.

### Analog and Digital Value Conversions

Sometimes it is useful to be able to quickly convert between the signal levels and the digital values. This is especially helpful during machine startup or troubleshooting. The following table provides formulas to make this conversion easier. Remember, if you embed the sign information into the data value, you must adjust the formulas accordingly.

Range	If you know the digital value ...	If you know the signal level ...
4 to 20mA	$A = \frac{16D}{4095} + 4$	$D = \frac{4095}{16} (A - 4)$

For example, if you know you need a 10mA signal to achieve the desired result, you can easily determine the digital value that should be used.

$$D = \frac{4095}{16} (A - 4)$$

$$D = \frac{4095}{16} (10\text{mA} - 4)$$

$$D = (255.93) (6)$$

$$D = 1536$$

# F2-08DA-2

## 8-Channel Analog Voltage Output

---

In This Chapter. . . .

- Module Specifications
  - Setting the Module Jumper
  - Connecting the Field Wiring
  - Module Operation
  - Writing the Control Program
-

## Module Specifications

The F2-08DA-2 Analog Output module provides several hardware features:

- Supports DL230, DL240, DL250-1 and DL260 CPUs (see firmware requirements below).
- Analog outputs are optically isolated from the PLC logic.
- The module has a removable terminal block, so the module can be easily removed or changed without disconnecting the wiring.
- Can update all channels in one scan (DL240, DL250-1 and DL260 only).
- Outputs are voltage sourcing.
- Outputs can be configured for either of these ranges:
  - 1) 0 to 5 VDC
  - 2) 0 to 10 VDC

### Firmware Requirements:

To use this module, DL230 CPUs must have firmware version 2.7 or later. To use the pointer method of writing values, DL240 CPUs require firmware version 3.0 or later and DL250 CPUs require firmware version 1.33 or later.

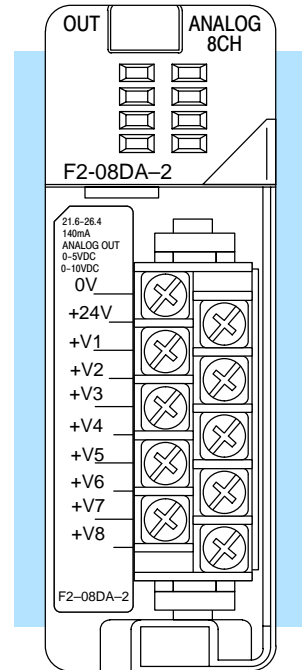

F2-08DA-2

The following tables provide the specifications for the F2-08DA-2 Analog Output Module. Review these specifications to make sure the module meets your application requirements.

### Output Specifications

Number of Channels	8, single-ended
Output Ranges	0 to 5V, 0 to 10V
Resolution	12 bit (1 in 4096)
Output Type	Voltage sourcing
Peak Output Voltage	15VDC (clamped by transient voltage suppressor)
Load Impedance	1k $\Omega$ – 10k $\Omega$
Load Capacitance	.01 $\mu$ F maximum
Linearity Error (end to end)	$\pm$ 1 count ( $\pm$ 0.025% of full scale) maximum
Conversion Settling Time	400 $\mu$ s maximum (full scale change) 4.5ms to 9ms for digital out to analog out
Full-Scale Calibration Error (offset error included)	$\pm$ 12 counts max. @ 25°C (77°F)
Offset Calibration Error	$\pm$ 3 counts maximum @ 25°C (77°F)
Accuracy vs. Temperature	$\pm$ 57 ppm/°C full scale calibration change (including maximum offset change of 2 counts)
Maximum Inaccuracy	$\pm$ 0.3% @ 25°C (77°F) $\pm$ 0.45% 0–60°C (32–140°F)

### General Specifications

PLC Update Rate	1 channel per scan maximum (Multiplexing) 8 channels per scan maximum (Pointer [DL240/DL250–1/260 only])
Digital Outputs / Output Points Required	12 binary data bits, 3 ch. ID bits, 1 output enable bit / 16 (Y) output points required
Power Budget Requirement	60 mA @ 5VDC (supplied by base)
External Power Supply	24VDC ( $\pm$ 10%), 140mA (outputs fully loaded)
Operating Temperature	0 to 60° C (32 to 140° F)
Storage Temperature	–20 to 70° C (–4 to 158° F)
Relative Humidity	5 to 95% (non-condensing)
Environmental Air	No corrosive gases permitted
Vibration	MIL STD 810C 514.2
Shock	MIL STD 810C 516.2
Noise Immunity	NEMA ICS3–304

One count in the specification table is equal to one least significant bit of the analog data value (1 in 4096).

### Analog Output Configuration Requirements

The F2-08DA-2 analog output requires 16 discrete output points. The module can be installed in any slot of a DL205 system, but the available power budget and discrete I/O points can be limiting factors. Check the user manual for your particular model of CPU and I/O base for more information regarding power budget and number of local, local expansion or remote I/O points.

**Special Placement Requirements (DL230 and Remote I/O Bases)**

Even though the module can be placed in any slot, it is important to examine the configuration. As you can see in the section on writing the program, you use V-memory locations to extract the analog data. If you place the module so the output points do not start on a V-memory boundary, the instructions cannot access the data. This also applies when module is placed in remote base (D2-RSSS in CPU slot).

**Correct!**

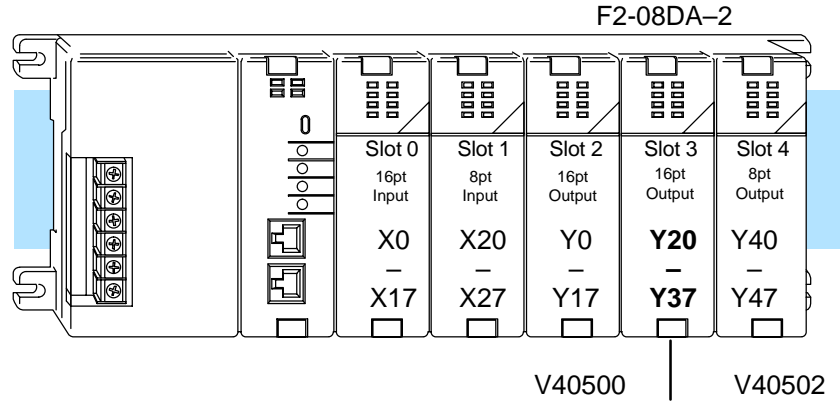

Data is correctly entered so output points start on a V-memory boundary.

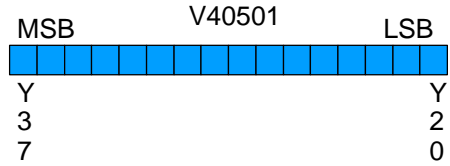

**Incorrect**

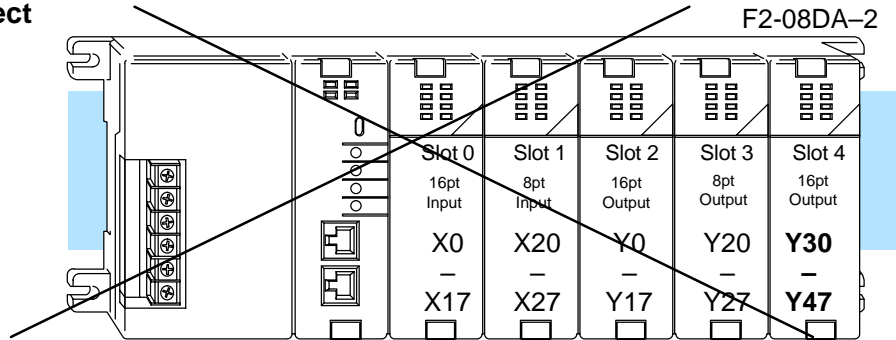

Data is split over two locations, so instructions cannot access data from a DL230 (or when module is placed in a remote base).

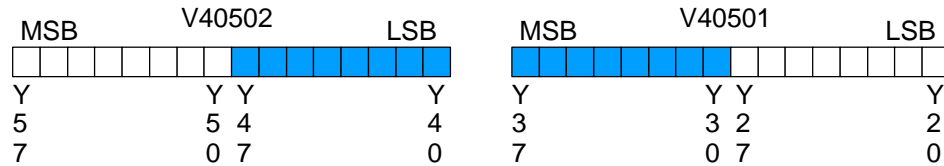

To use the V-memory references required for the multiplexing method, the first output address assigned to the module must be one of the following Y locations. The table also shows the V-memory addresses that correspond to these Y locations.

<b>Y</b>	Y0	Y20	Y40	Y60	Y100	Y120	Y140	Y160
<b>V</b>	V40500	V40501	V40502	V40503	V40504	V40505	V40506	V40507

## Setting the Module Jumper

The F2-08DA-2 Analog Output module uses a jumper for selecting the 0–5V or 0–10V voltage ranges.

This figure shows the jumper location and how to set it for either voltage range.

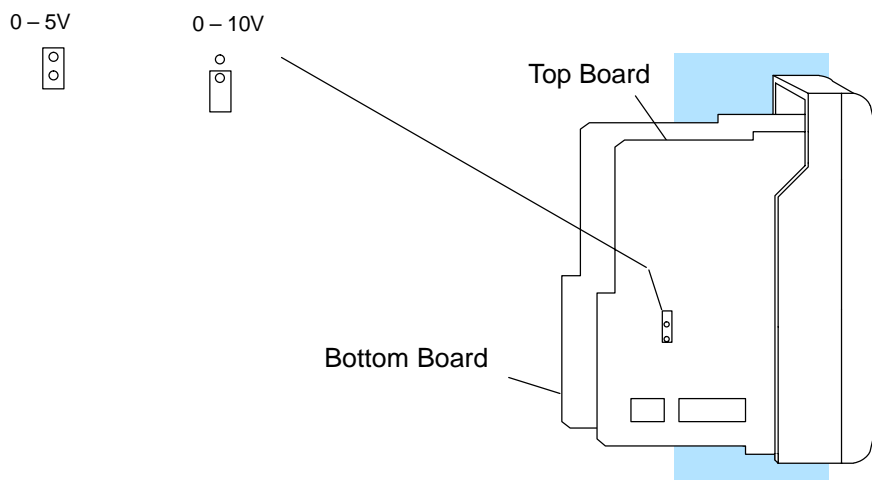

### Voltage Range and Output Combinations

The table lists both possible combinations of voltage ranges and data formats, along with the corresponding jumper settings.

Voltage Range	Output Data Format	Jumpers Setting (top board)
0 to 5V	0–4095	Install
0 to 10V	0–4095	Remove

These graphs show the voltage range to output data format relationship for each of the two selections.

### Ranges

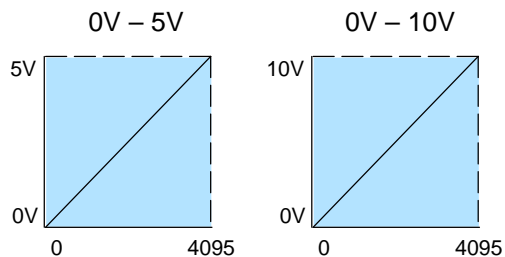

## Connecting the Field Wiring

### Wiring Guidelines

Your company may have guidelines for wiring and cable installation. If so, you should check those before you begin the installation. Here are some general things to consider:

- Use the shortest wiring route whenever possible.
- Use shielded wiring and ground the shield at the signal source. *Do not* ground the shield at both the module and the load.
- Do not run the signal wiring next to large motors, high current switches, or transformers. This may cause noise problems.
- Route the wiring through an approved cable housing to minimize the risk of accidental damage. Check local and national codes to choose the correct method for your application.

### User Power Supply Requirements

The F2-08DA-2 requires a separate field-side power supply. Each module requires 21.6–26.4VDC at up to 140mA current. The DL205 bases have built-in 24 VDC power supplies that provide up to 300mA of current. If you are using only a couple of analog modules, you can use this power source instead of a separate supply. If you want to use a separate supply, choose one that meets the power requirements of your application.



**WARNING:** If you are using 24 VDC output power from the base, make sure you calculate the power budget. Exceeding the power budget can cause unpredictable system operation that can lead to a risk of personal injury or damage to equipment.

### Wiring Diagram

The F2-08DA-2 module has a removable connector to make wiring easier. Squeeze the latches on both ends of the connector and gently pull it from the module. Use the following diagram to connect the field wiring.

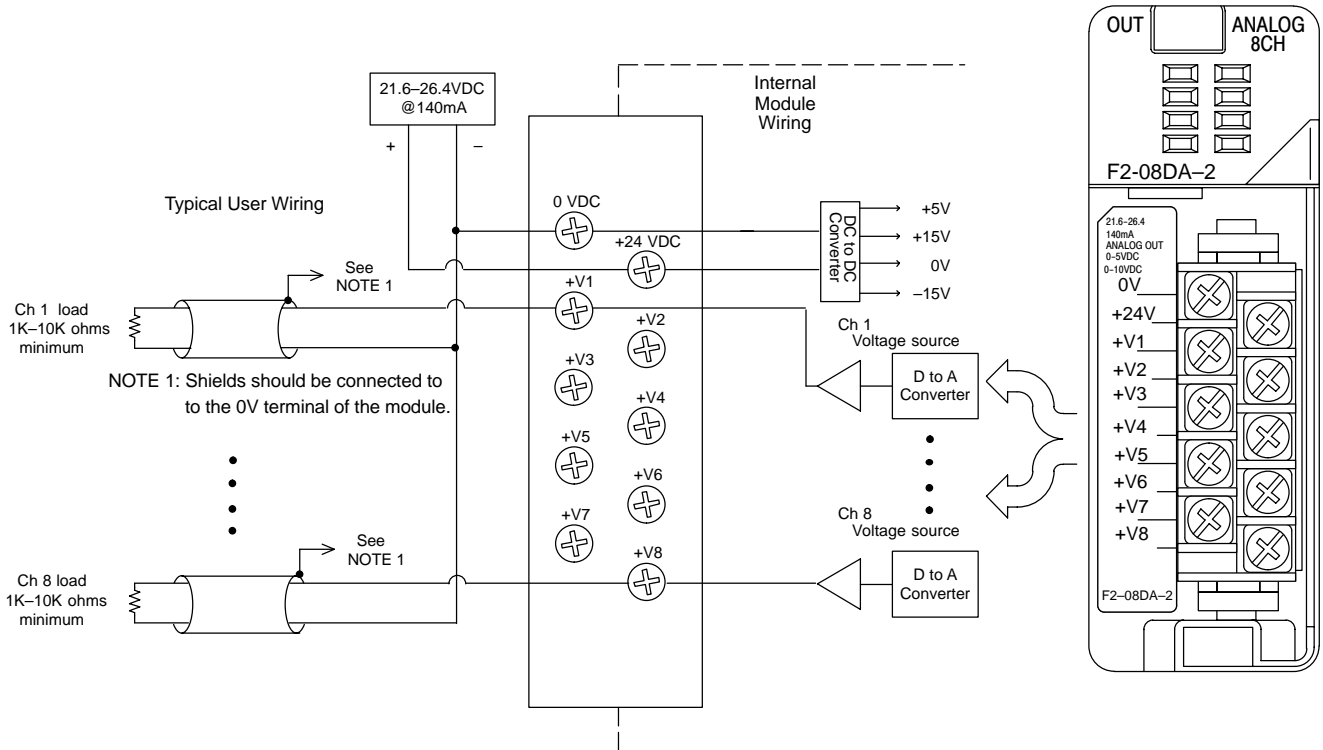

# Module Operation

## Channel Update Sequence for a DL230 CPU (Multiplexing)

Before you begin writing the control program, it is important to take a few minutes to understand how the module processes and represents the analog signals.

If you are using multiplexing ladder, you can send one channel of data to the output module on each scan. The module refreshes both field devices on each scan, but you can only get new data from the CPU at the rate of one channel per scan. Since there are eight channels, it can take eight scans to update all channels. However, if you are only using one channel, you can update that channel on every scan. The multiplexing method can also be used for the DL240/250-1/260 CPUs.

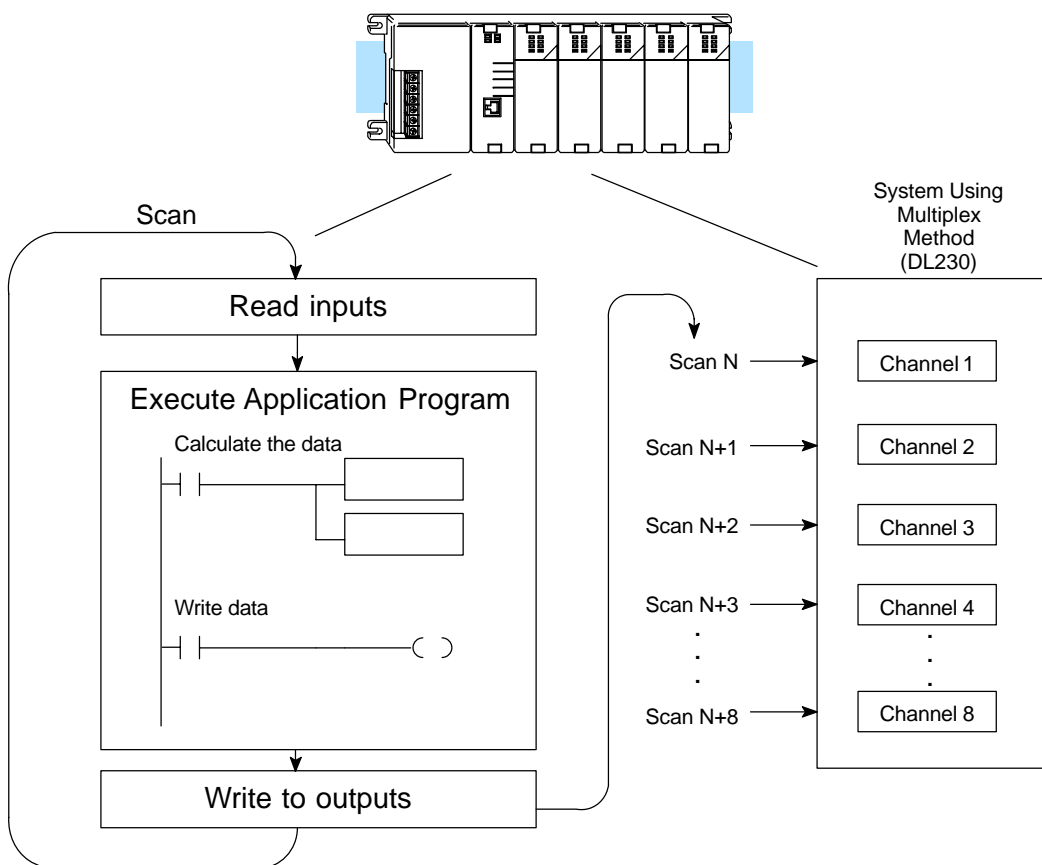

### Channel Update Sequence for a DL240, DL250-1 or DL260 CPU (Pointer Method)

If you are using pointers (Pointer Method), you can update all channels on every scan. This is because the DL240/250-1/260 CPU supports special V-memory locations that are used to manage the data transfer. This is discussed in more detail in the section on Writing the Control Program.

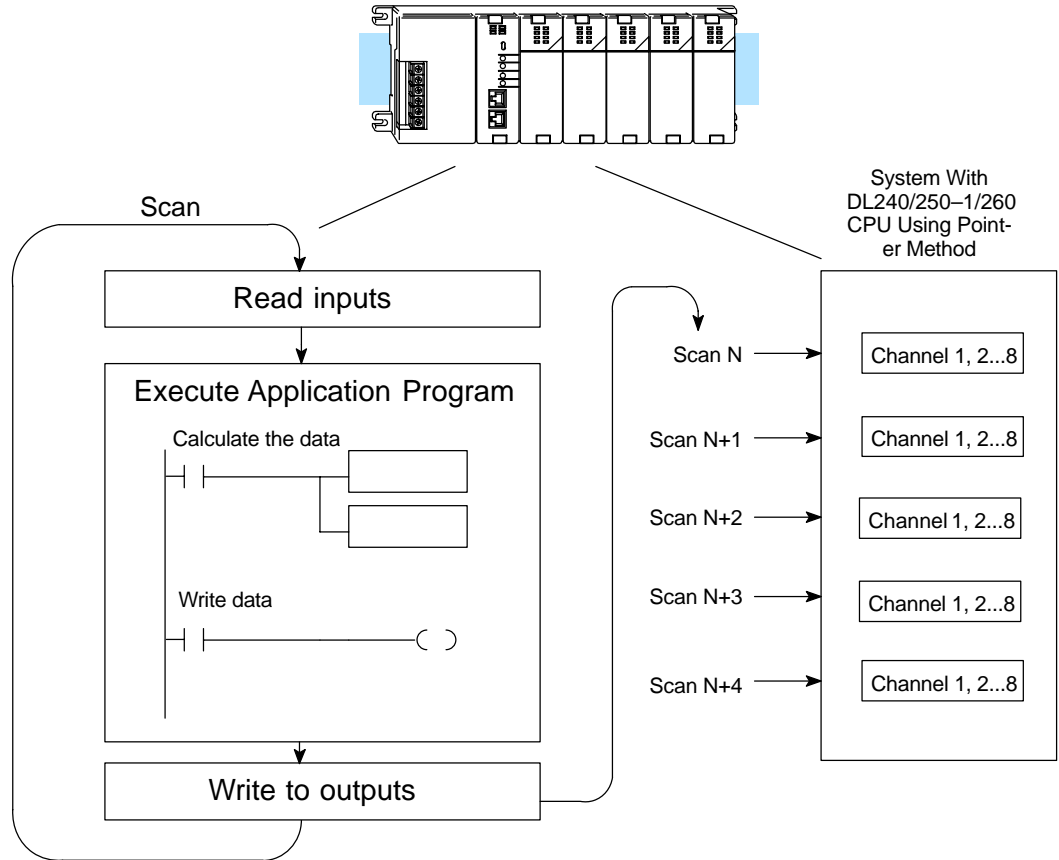

**Understanding the Output Assignments**

You may recall the F2-08DA-2 module requires 16 discrete output points in the CPU. These points provide the data value and an indication of which channel to update. Note, if you are using a DL240/250-1/260 CPU, you may never have to use these bits, but it may help you understand the data format.

Since all output points are automatically mapped into V-memory, it is very easy to determine the location of the data word that will be assigned to the module.

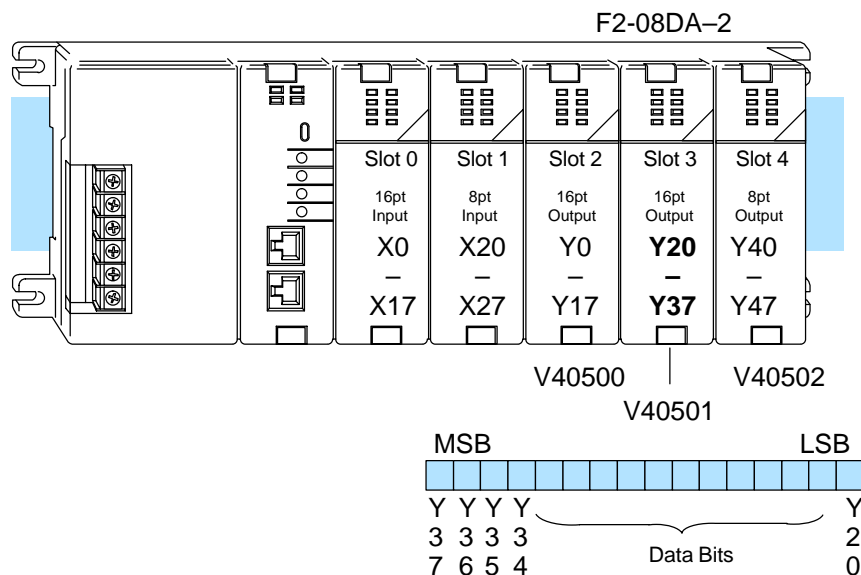

Within this word location, the individual bits represent specific information about the analog signal.

**Channel Select Outputs**

Three of the outputs select the active channel. Remember, the V-memory bits are mapped directly to discrete outputs. The binary weight of these three bits determines the selected channel. By controlling these outputs, you can select which channel gets updated.

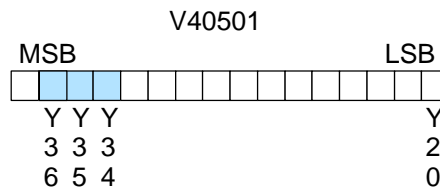

= channel select outputs

Y36	Y35	Y34	Channel Number Selected
			1
		X	2
	X		3
	X	X	4
X			5
X		X	6
X	X		7
X	X	X	8

**Analog Data Bits** The first twelve bits represent the analog data in binary format.

Bit	Value	Bit	Value
0	1	6	64
1	2	7	128
2	4	8	256
3	8	9	512
4	16	10	1024
5	32	11	2048

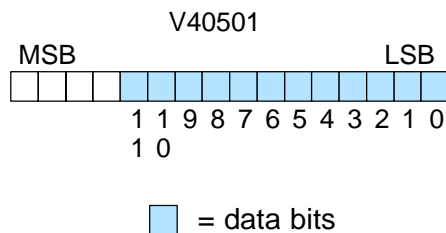

**Output Enable** The last output can be used to update outputs. If this output is off the outputs are cleared.

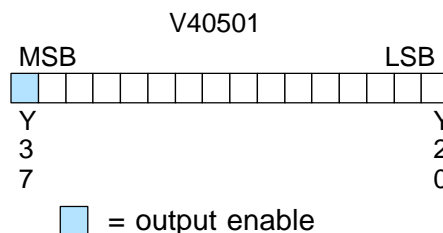

**Module Resolution** Since the module has 12-bit resolution, the analog signal is converted from 4096 counts ranging from 0–4095 ( $2^{12}$ ). For example, with a 0 to 10V range, send a 0 to get a 0V signal, and send 4095 to get a 10V signal. This is equivalent to a binary value of 0000 0000 0000 to 1111 1111 1111, or 000 to FFF hexadecimal.

Each count can also be expressed in terms of the signal level by using the following equation:

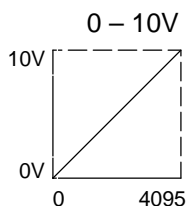

$$\text{Resolution} = \frac{H - L}{4095}$$

H = high limit of the signal range

L = low limit of the signal range

The following table shows the smallest change in signal level due to a digital value change of 1 LSB count.

Voltage Range	Signal Span	Divide By	Smallest Output Change
0 to 5V	5 volts	4095	1.22 mV
0 to 10V	10 volts	4095	2.44 mV

## Writing the Control Program

### Calculating the Digital Value

Your program has to calculate the digital value to send to the analog module. There are many ways to do this, but most applications are understood more easily if you use measurements in engineering units. This is accomplished by using the conversion formula shown.

You may have to make adjustments to the formula depending on the scale you choose for the engineering units.

$$A = U \frac{4095}{H - L} \quad \text{for 0-4095 output format}$$

A = Analog value (0 – 4095)

U = Engineering units

H = High limit of the engineering unit range

L = Low limit of the engineering unit range

Consider the following example which controls pressure from 0.0 to 99.9 PSI. By using the formula you can easily determine the digital value that should be sent to the module. The example shows the conversion required to yield 49.4 PSI. Notice the formula uses a multiplier of 10. This is because the decimal portion of 49.4 cannot be loaded, so you must adjust the formula to compensate for it.

$$A = 10U \frac{4095}{10(H - L)} \qquad A = 494 \frac{4095}{1000 - 0} \qquad A = 2023$$

The following example program shows how you would write the program to perform the engineering unit conversion to output data formats 0-4095. This example assumes you have calculated or loaded the engineering unit values in BCD format and stored them in V2300 and V2301 for channels 1 and 2 respectively. The DL205 offers instructions that allow you to perform math operations using BCD format. It is usually easier to perform any math calculations in BCD and then convert the value to binary before you send the data to the module.

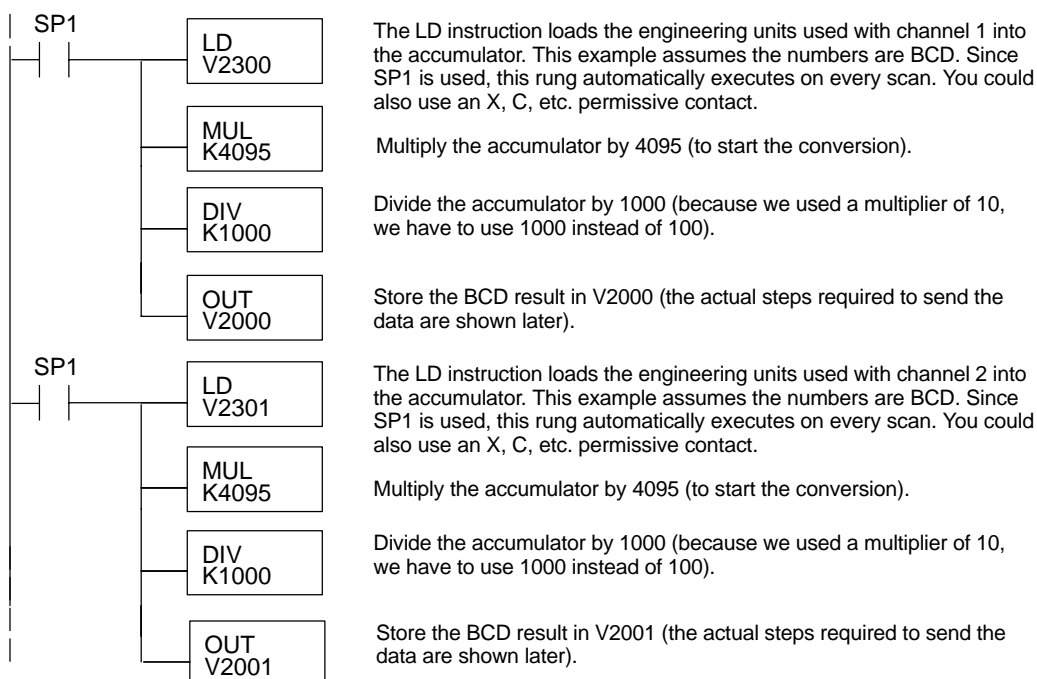

### Writing Values: Pointer Method and Multiplexing

There are two methods of reading values:

- The pointer method
- Multiplexing method

You can use either method when using DL240, DL250-1 and DL260 CPUs, but for ease of programming it is strongly recommended that you use the pointer method. You must use the multiplexing method when using DL230 CPUs and with remote I/O modules (the pointer method will not work).

Once you have calculated the data values (shown previously) you must enter the program that actually updates the module. The DL240/250-1/260 has special V-memory locations assigned to each base slot that greatly simplify the programming requirements. By using these V-memory locations you can:

- specify the number of channels to update.
- specify where to obtain the output data .

### Pointer Method Example

✗	✓	✓	✓
230	240	250-1	260



**NOTE:** DL240 CPUs with firmware release version 3.0 or later and DL250 CPUs with firmware release 1.33 are required to support this method.

The following program example shows how to setup these locations. Place this rung anywhere in the ladder program, or in the initial stage if you are using stage programming. You may recall in the previous example we used V2000 through V2007 to store the calculated values. Also, in the previous examples we had the analog module installed in slot 3. You should use the appropriate memory locations for your application. The pointer method automatically converts values to binary.

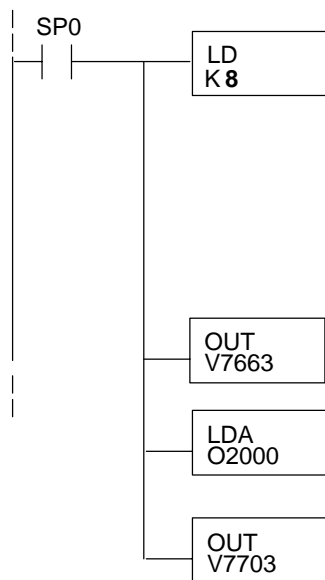

- or - LD  
K88

Loads a constant that specifies the number of channels to scan and the data format. The lower byte, most significant nibble (MSN) selects the data format (0=BCD, 8=Binary), the LSN selects the number of channels (1-8).

The binary format is used for displaying data on some operator interfaces. The DL230/240 CPUs do not support binary math functions, whereas the DL250 does.

Special V-memory location assigned to slot 3 that contains the number of channels to scan.

This loads an octal value for the first V-memory location that will be used to store the output data. For example, the O2000 entered here would designate the following addresses:  
Ch1 - V2000, Ch 2 - V2001.....Ch8 - V2007

The octal address (O2000) is stored here. V7703 is assigned to slot 3 and acts as a pointer, which means the CPU will use the octal value in this location to determine exactly where to store the output data.

The tables below show the special V-memory locations used by the DL240, DL250-1 and DL260 for the CPU base and local expansion base I/O slots. Slot 0 (zero) is the module next to the CPU or D2-CM module. Slot 1 is the module two places from the CPU or D2-CM, and so on. Remember, the CPU only examines the pointer values at these locations after a mode transition. Also, if you use the DL230 (multiplexing) method, verify that these addresses in the CPU are zero.

The Table below applies to the DL240, DL250-1 and DL260 CPU base.

CPU Base: Analog Output Module Slot-Dependent V-memory Locations								
Slot	0	1	2	3	4	5	6	7
No. of Channels	V7660	V7661	V7662	V7663	V7664	V7665	V7666	V7667
Storage Pointer	V7700	V7701	V7702	V7703	V7704	V7705	V7706	V7707

The Table below applies to the DL250-1 or DL260 expansion base 1.

Expansion Base D2-CM #1: Analog Output Module Slot-Dependent V-memory Locations								
Slot	0	1	2	3	4	5	6	7
No. of Channels	V36000	V36001	V36002	V36003	V36004	V36005	V36006	V36007
Storage Pointer	V36020	V36021	V36022	V36023	V36024	V36025	V36026	V36027

The Table below applies to the DL250-1 or DL260 expansion base 2.

Expansion Base D2-CM #2: Analog Output Module Slot-Dependent V-memory Locations								
Slot	0	1	2	3	4	5	6	7
No. of Channels	V36100	V36101	V36102	V36103	V36104	V36105	V36106	V36107
Storage Pointer	V36120	V36121	V36122	V36123	V36124	V36125	V36126	V36127

The Table below applies to the DL260 CPU expansion base 3.

Expansion Base D2-CM #3: Analog Output Module Slot-Dependent V-memory Locations								
Slot	0	1	2	3	4	5	6	7
No. of Channels	V36200	V36201	V36202	V36203	V36204	V36205	V36206	V36207
Storage Pointer	V36220	V36221	V36222	V36223	V36224	V36225	V36226	V36227

The Table below applies to the DL260 CPU expansion base 4.

Expansion Base D2-CM #4: Analog Output Module Slot-Dependent V-memory Locations								
Slot	0	1	2	3	4	5	6	7
No. of Channels	V36300	V36301	V36302	V36303	V36304	V36305	V36306	V36307
Storage Pointer	V36320	V36321	V36322	V36323	V36324	V36325	V36326	V36327

### Writing Data (Multiplexing)

✓	✓	✓	✓
230	240	250-1	260

The following example shows how to write data using the multiplexing method.

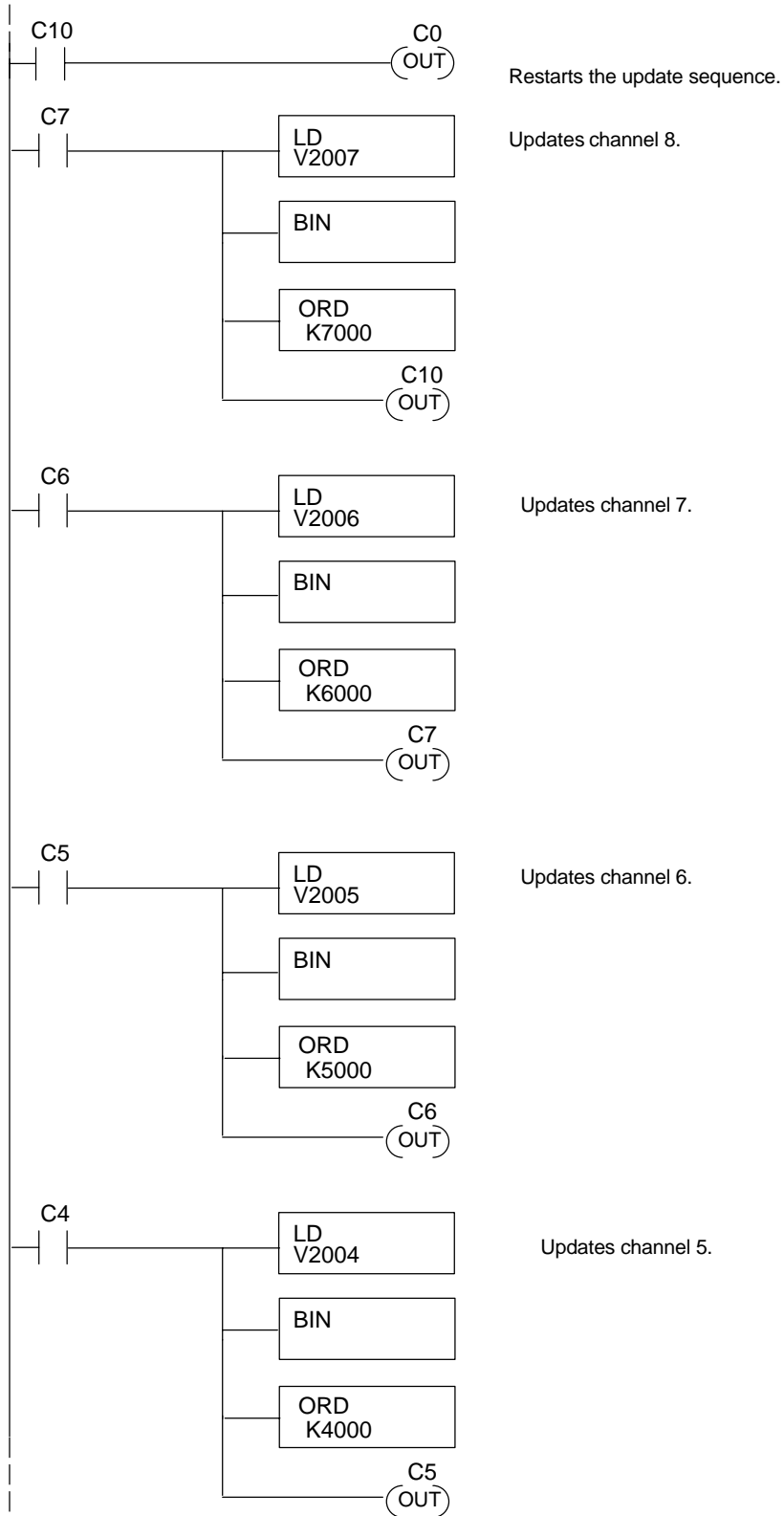

Continued

Writing Data  
(Multiplexing  
Example)  
Continued

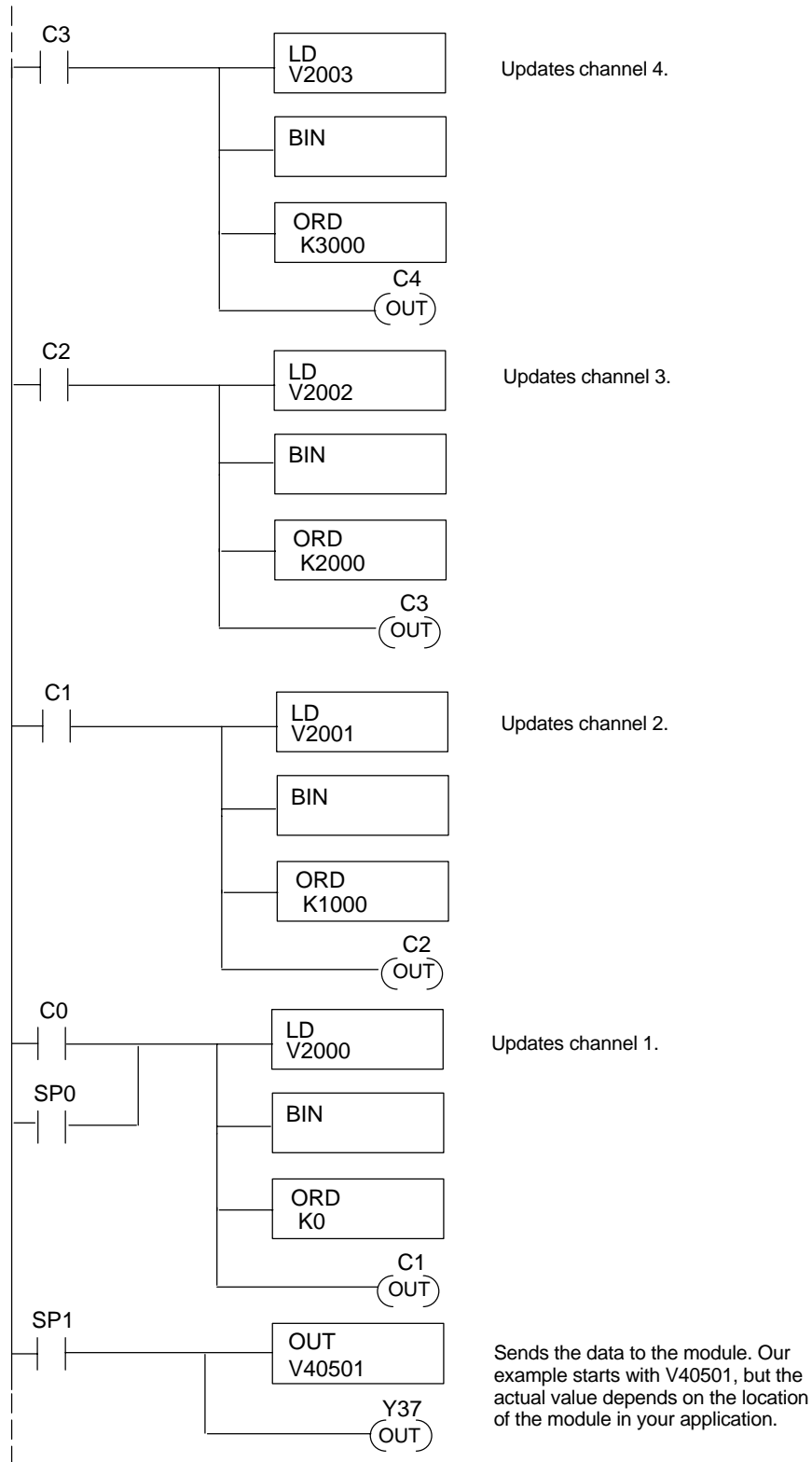

### Sending Data to One Channel

If you are using more than one channel, or if you want to control the updates separately, use the following program.

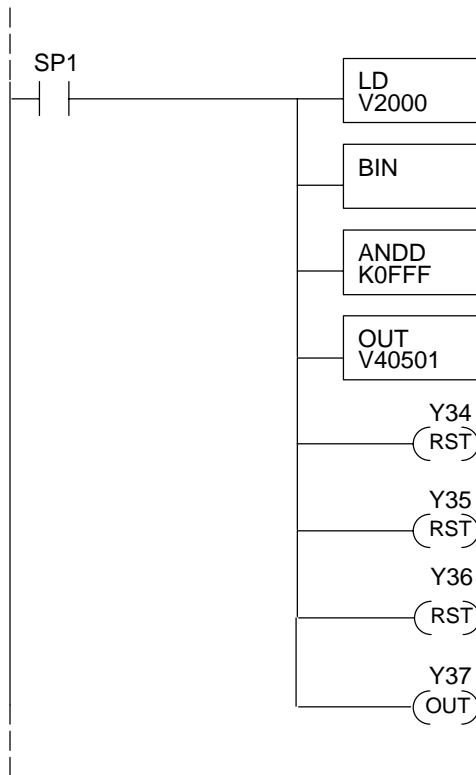

The LD instruction loads the data into the accumulator. Since SP1 is used, this rung automatically executes on every scan. You could also use an X, C, etc. permissive contact.

The BIN instruction converts the accumulator data to binary (you must omit this step if you have already converted the data elsewhere).

The ANDD instruction masks off the channel select bits to prevent an accidental channel selection.

The OUT instruction sends the data to the module. Our example starts with V40501, but the actual value depends on the location of the module in your application.

Y34, Y35, Y36—OFF selects channel 1 for updating.

Y37 is the output enable bit.

### Analog and Digital Value Conversions

Sometimes it is useful to be able to quickly convert between the signal levels and the digital values. This is especially helpful during machine startup or troubleshooting. The following table provides formulas to make this conversion easier. Remember, if you embed the sign information into the data value, you must adjust the formulas accordingly.

Range	If you know the digital value ...	If you know the signal level ...
0 to 10V	$A = \frac{10D}{4095}$	$D = \frac{4095}{10} (A)$
0 to 5V	$A = \frac{5D}{4095}$	$D = \frac{4095}{5} (A)$

For example, if you are using the 0–10V range and you know you need a 6V signal level, use this formula to determine the digital value (D) that will be stored in the V-memory location that contains the data.

$$D = \frac{4095}{10} (A)$$

$$D = \frac{4095}{10} (6V)$$

$$D = (409.5) (6)$$

$$D = 2457$$

# **F2-02DAS-1 4–20mA 2-Channel Analog Current Output**

---

In This Chapter. . . .

- Module Specifications
  - Connecting the Field Wiring
  - Module Operation
  - Writing the Control Program
-

## Module Specifications

The F2-02DAS-1 Analog Output module provides several hardware features:

- Supports DL230, DL240, DL250-1 and DL260 CPUs (see firmware requirements below).
- Analog outputs are isolated from channel to channel and channel to PLC logic.
- The module has a removable terminal block so the module can be easily removed or changed without disconnecting the wiring.
- Can update both channels in one scan (DL240/DL250-1/260 only)
- Loop power supply requirements: 18-32VDC
- Outputs are sourced through external loop supply

### Firmware Requirements:

To use this module, DL230 CPUs must have firmware version 1.7 or later. To use the pointer method of writing values, DL240 CPUs require firmware version 2.9 or later and DL250 CPUs require firmware version 1.30 or later.

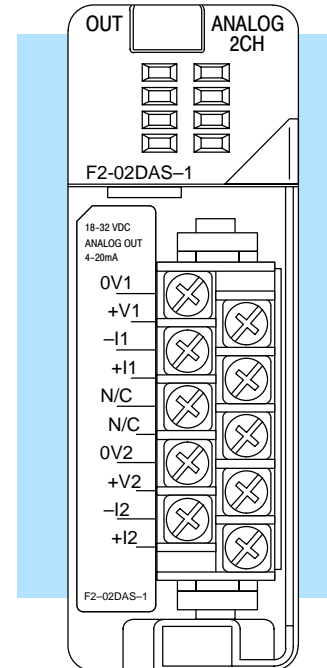

F2-02DAS-1

The following tables provide the specifications for the F2-02DAS-1 Isolated Analog Output Module. Review these specifications to make sure the module meets your application requirements.

### Output Specifications

Number of Channels	2, isolated (2 commons)
Output Range	4 to 20 mA
Resolution	16 bit (1 in 65536)
Output Type	Current sourcing
Isolation Voltage	± 750V continuous, channel to channel, channel to logic
Loop Supply	18-32VDC
Load Impedance	0Ω - 525Ω
Linearity Error (end to end)	± 10 counts (± 0.015% of full scale) maximum
Conversion Settling time	3ms to 0.1% of full scale
Gain Calibration Error	± 32 counts (± 0.05%)
Offset Calibration Error	± 13 counts (± 0.02%)
Output Drift	50 ppm/°C
Maximum Inaccuracy	± 0.07% @ 25°C (77°F) ± 0.18% @ 0 to 60°C (32 to 140°F)

### General Specifications

PLC Update Rate	1 channel per scan maximum (Multiplexing) 2 channels per scan maximum (Pointer [DL240, DL250, DL260 only])
Digital outputs Output points required	16 binary data bits, 2 channel ID bits; 32 point (Y) output module
Power Budget Requirement	100 mA @ 5 VDC (supplied by base)
External Power	18-32VDC @ 50mA per channel, Class 2
Operating Temperature	0 to 60° C (32 to 140° F)
Storage Temperature	-20 to 70° C (-4 to 158° F)
Relative Humidity	5 to 95% (non-condensing)
Environmental air	No corrosive gases permitted
Vibration	MIL STD 810C 514.2
Shock	MIL STD 810C 516.2
Noise Immunity	NEMA ICS3-304

One count in the specification table is equal to one least significant bit of the analog data value (1 in 65536).

### Analog Output Configuration Requirements

The F2-02DAS-1 analog output requires 32 discrete output points. The module can be installed in any slot of a DL205 system, but the available power budget and discrete I/O points can be limiting factors. Check the user manual for your particular model of CPU and I/O base for more information regarding power budget and number of local, local expansion or remote I/O points.



# Connecting the Field Wiring

## Wiring Guidelines

Your company may have guidelines for wiring and cable installation. If so, you should check those before you begin the installation. Here are some general things to consider:

- Use the shortest wiring route whenever possible.
- Use shielded wiring and ground the shield at the signal source. *Do not* ground the shield at both the module and the load.
- Do not run the signal wiring next to large motors, high current switches, or transformers. This may cause noise problems.
- Route the wiring through an approved cable housing to minimize the risk of accidental damage. Check local and national codes to choose the correct method for your application.

## Loop Power Supply Requirements

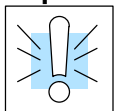

The F2-02DAS-1 requires a separate field-side loop power supply. Each module requires 18-32VDC at up to 50mA per channel (or 100mA).

**WARNING:** If you are using 24 VDC power from the base, make sure you calculate the power budget. Exceeding the power budget can cause unpredictable system operation that can lead to a risk of personal injury or damage to equipment.

## Wiring Diagram

The F2-02DAS-1 module has a removable connector to make wiring easier. Simply squeeze the top and bottom retaining clips and gently pull the connector from the module. Use the following diagram to connect the field wiring.

NOTE 1: Shields should be connected to the 0V terminal of the module.

NOTE 2: Loads must be within the compliance voltage.

NOTE 3: For non-isolated outputs, connect all 0V's together (0V1.....0V2) and connect all +V's together (+V1.....+V2).

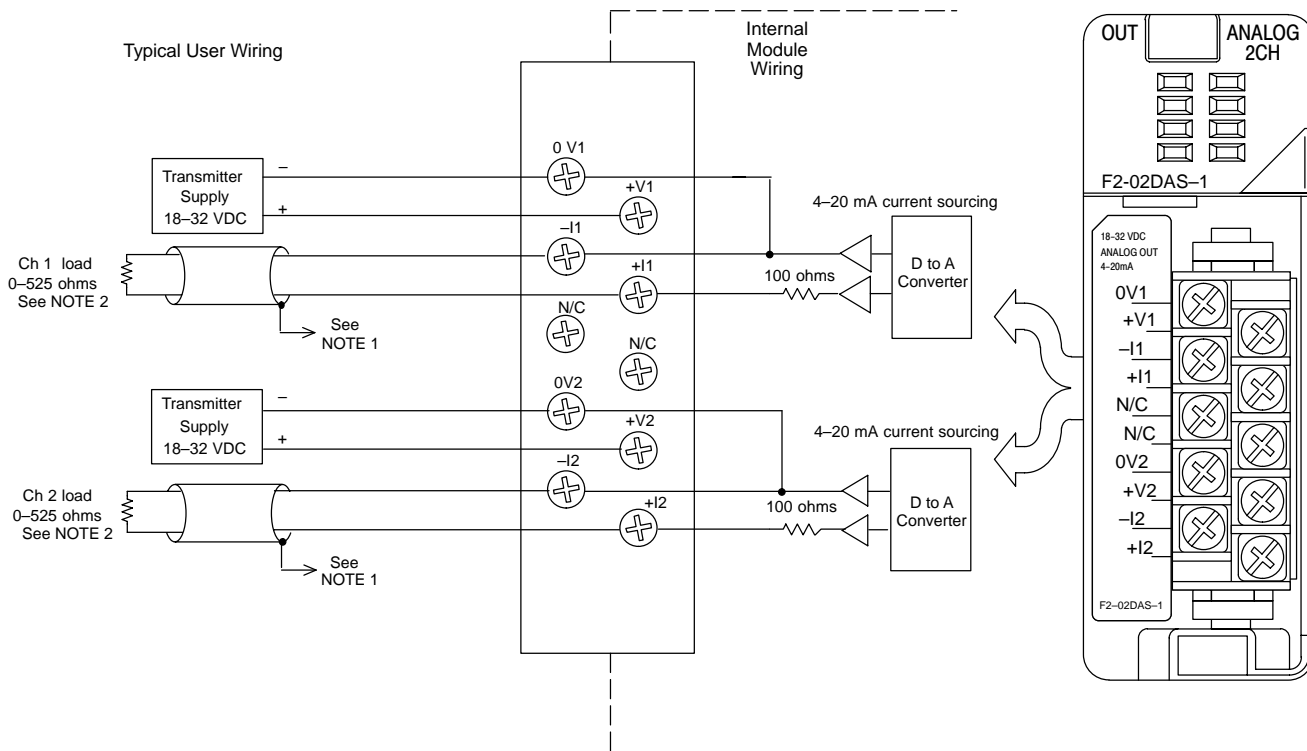

# Module Operation

## Channel Update Sequence for a DL230 CPU (Multiplexing)

Before you begin writing the control program, it is important to take a few minutes to understand how the module processes and represents the analog signals.

If you are using multiplexing ladder, you can send one channel of data to the output module on each scan. The module refreshes both field devices on each scan, but you can only get new data from the CPU at the rate of one channel per scan. Since there are two channels, it can take two scans to update both channels. However, if you are only using one channel, then you can update that channel on every scan. The multiplexing method can also be used for the DL240/250-1/260 CPUs.

F2-02DAS-1  
2-Ch. Iso. Current Output

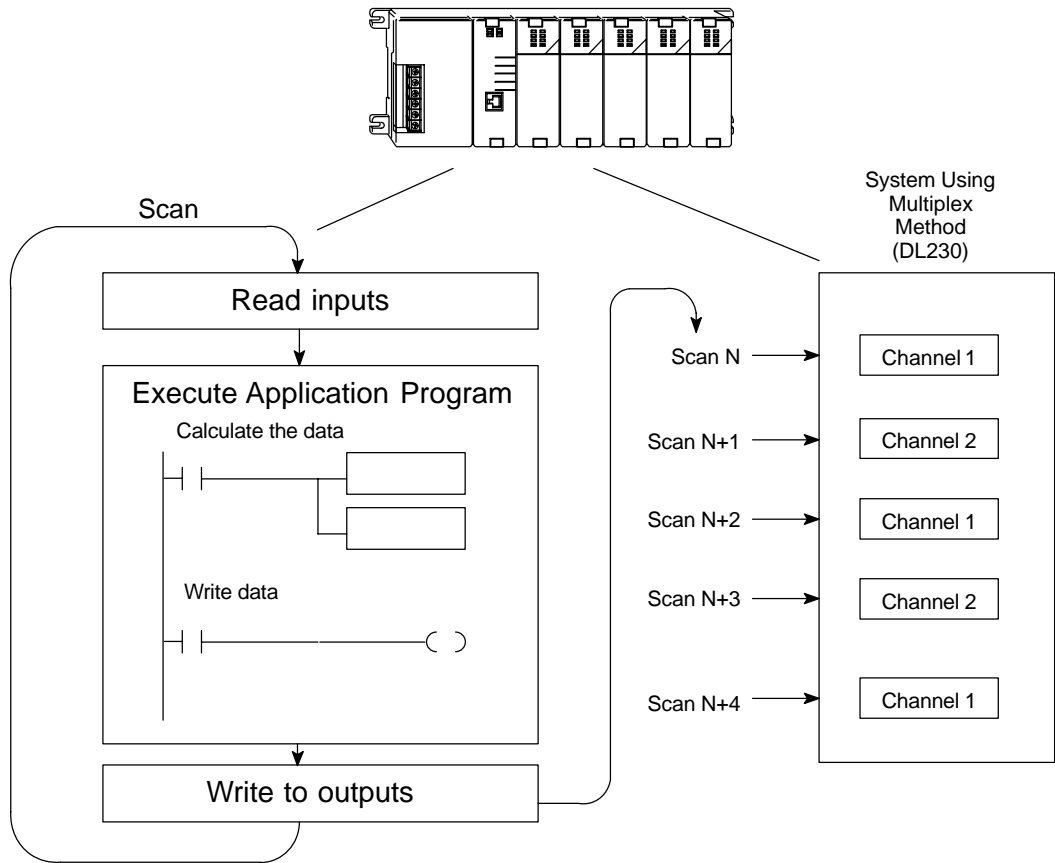

**Channel Update Sequence for a DL240, DL250-1 or DL260 CPU (Pointer Method)**

If you are using pointers (Pointer Method), you can update both channels on every scan. This is because the D2-240, DL250-1 and D2-260 CPUs support special V-memory locations that are used to manage the data transfer. This is discussed in more detail in the section on Writing the Control Program.

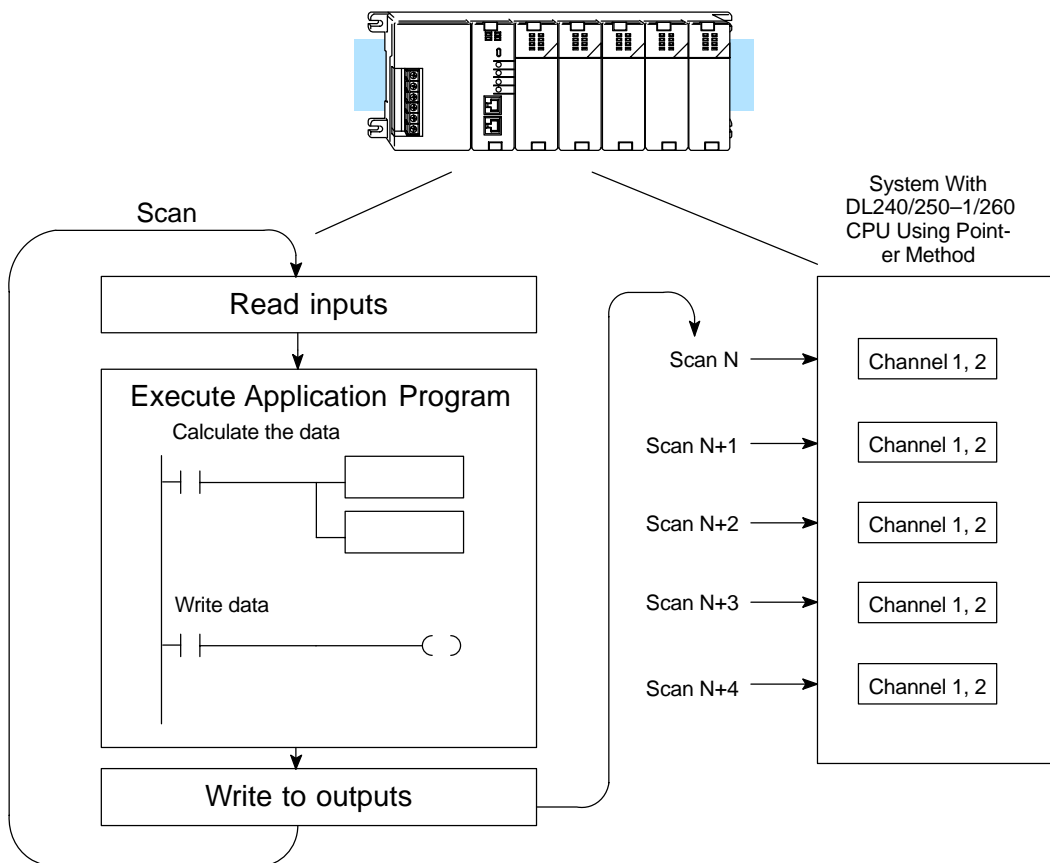

F2-02DAS-1  
2-Ch. Iso. Current Output

### Understanding the Output Assignments

You may recall the F2-02DAS-1 module appears to the CPU as a 32-point discrete output module. These points provide the data value and an indication of which channel to update. Note, if you are using a DL240/250-1/260 CPU, you may never have to use these bits, but it may help you understand the data format.

Since all output points are automatically mapped into V-memory, it is very easy to determine the location of the data word that will be assigned to the module.

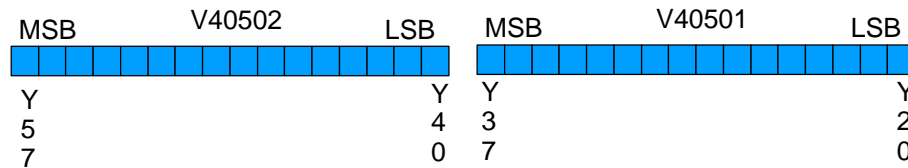
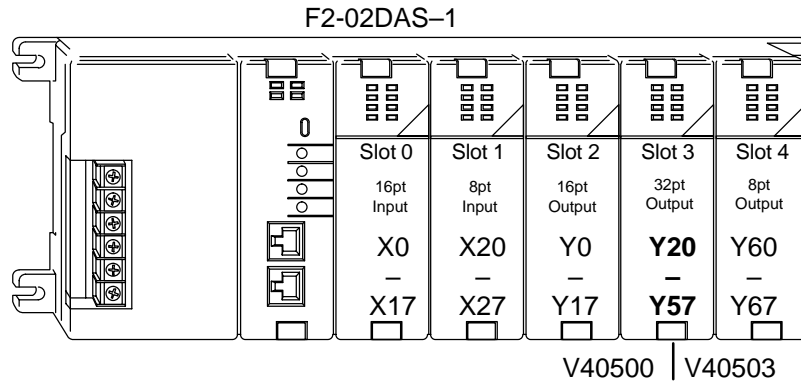

Within this word location, the individual bits represent specific information about the analog signal.

### Channel Select Outputs

Two of the outputs select the active channel. Remember, the V-memory bits are mapped directly to discrete outputs. Turning a bit OFF selects its channel. By controlling these outputs, you can select which channel(s) gets updated.

Y41	Y40	Channel
On	Off	1
Off	On	2
Off	Off	1 & 2 (same data to both channels)
On	On	none (both channels hold current values)

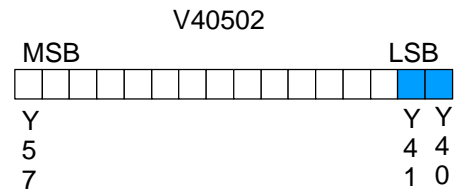

= channel select outputs

**Analog Data Bits** The first sixteen bits represent the analog data in binary format.

Bit	Value	Bit	Value
0	1	8	256
1	2	9	512
2	4	10	1024
3	8	11	2048
4	16	12	4096
5	32	13	8192
6	64	14	16384
7	128	15	32768

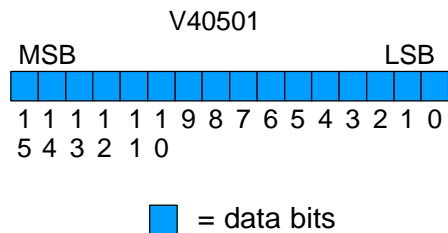

**Module Resolution**

Since the module has 16-bit resolution, the analog signal is converted into 65536 counts ranging from 0 – 65535 ( $2^{16}$ ). For example, send a 0 to get a 4mA signal and 65535 to get a 20mA signal. This is equivalent to a binary value of 0000 0000 0000 0000 to 1111 1111 1111 1111, or 0000 to FFFF hexadecimal. The diagram shows how this relates to the signal range.

Each count can also be expressed in terms of the signal level by using the equation shown.

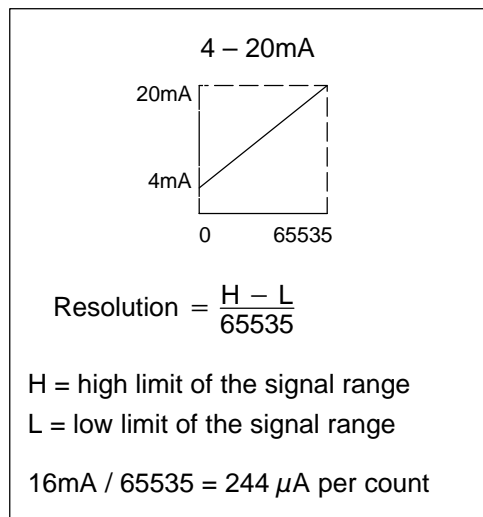

## Writing the Control Program

### Calculating the Digital Value

Your program must calculate the digital value to send to the analog module. There are many ways to do this, but most applications are understood more easily if you use measurements in engineering units. This is accomplished by using the conversion formula shown.

You may have to make adjustments to the formula depending on the scale you choose for the engineering units.

$$A = U \frac{65535}{H - L}$$

A = Analog value (0 – 65535)

U = Engineering Units

H = high limit of the engineering unit range

L = low limit of the engineering unit range

Consider the following example which controls pressure from 0.0 to 99.9 PSI. By using the formula, you can easily determine the digital value that should be sent to the module. The example shows the conversion required to yield 49.4 PSI. Notice the formula uses a multiplier of 10. This is because the decimal portion of 49.4 cannot be loaded, so you adjust the formula to compensate for it.

$$A = 10U \frac{65535}{10(H - L)}$$

$$A = 494 \frac{65535}{1000 - 0}$$

$$A = 32374$$

### Engineering Units Conversion

The example program shows how you would write the program to perform the engineering unit conversion to output data formats 0 – 65535 when using a DL250 CPU. This example assumes you have calculated or loaded the engineering unit values in BCD format and stored it in V2300 for channel 1.

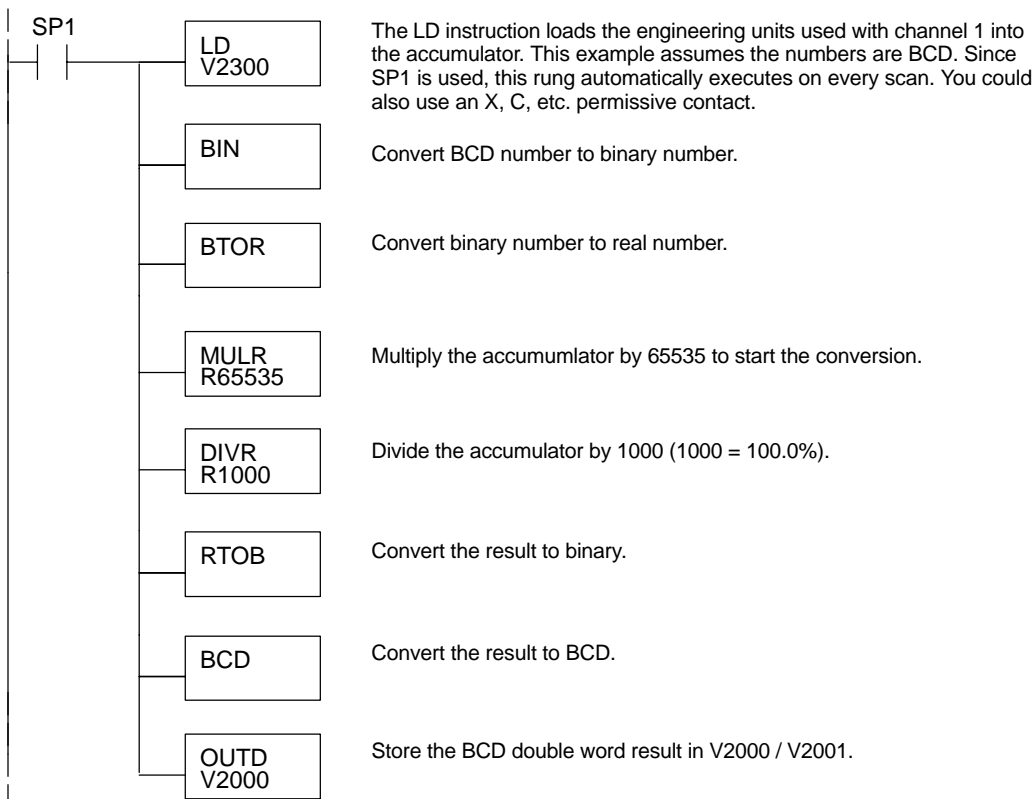

**Reading Values:  
Pointer Method  
and Multiplexing**

There are two methods of reading values:

- The pointer method
- Multiplexing

You can use either method when using DL240, DL250-1 and DL260 CPUs, but for ease of programming it is strongly recommended that you use the pointer method. You must use the multiplexing method with remote I/O modules (the pointer method will not work).

**Pointer Method**

✗	✓	✓	✓
230	240	250-1	260



Once you have calculated the data values (shown previously) you have to enter the program that actually updates the module. The DL240/250-1/260 has special V-memory locations assigned to each base slot that greatly simplify the programming requirements. By using these V-memory locations you can:

- specify the number of channels to update.
- specify where to obtain the output data.

**NOTE:** DL240 CPUs with firmware version 3.0 and DL250 CPUs with version 1.33 or later support this method.

The following program example shows how to set up these locations. Place this rung anywhere in the ladder program, or in the initial stage when using stage programming. You may recall in the previous examples we had used V2000 and V2001 to store the calculated values. Also, in the previous examples we had the analog module installed in slot 3. You should use the appropriate memory locations for your application. The pointer method automatically converts values to binary.

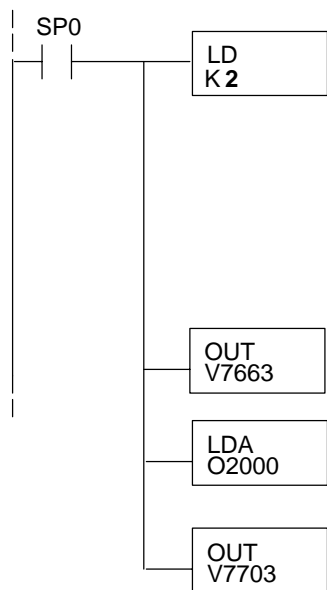

- or -

Loads a constant that specifies the number of channels to scan and the data format. The lower byte, most significant nibble (MSN) selects the data format (i.e. 0=BCD, 8=Binary), the LSN selects the number of channels (1 or 2).

The binary format is used for displaying data on some operator interfaces. The DL230/240 CPUs do not support binary math functions, whereas the DL250 does.

Special V-memory location assigned to slot 3 that contains the number of channels to scan.

This loads an octal value for the first V-memory location that will be used to store the output data. For example, the O2000 entered here would designate the following addresses.  
Ch1 - V2000, Ch2 - V2002

The octal address (O2000) is stored here. V7703 is assigned to slot 3 and acts as a pointer, which means the CPU will use the octal value in this location to determine exactly where to store the output data.

The tables below show the special V-memory locations used by the DL240, DL250–1 and DL260 for the CPU base and local expansion base I/O slots. Slot 0 (zero) is the module next to the CPU or D2–CM module. Slot 1 is the module two places from the CPU or D2–CM, and so on. Remember, the CPU only examines the pointer values at these locations after a mode transition. Also, if you use the DL230 (multiplexing) method, verify that these addresses in the CPU are zero.

The Table below applies to the DL240, DL250–1 and DL260 CPU base.

CPU Base: Analog Output Module Slot-Dependent V-memory Locations								
Slot	0	1	2	3	4	5	6	7
No. of Channels	V7660	V7661	V7662	V7663	V7664	V7665	V7666	V7667
Storage Pointer	V7700	V7701	V7702	V7703	V7704	V7705	V7706	V7707

The Table below applies to the DL250–1 or DL260 expansion base 1.

Expansion Base D2–CM #1: Analog Output Module Slot-Dependent V-memory Locations								
Slot	0	1	2	3	4	5	6	7
No. of Channels	V36000	V36001	V36002	V36003	V36004	V36005	V36006	V36007
Storage Pointer	V36020	V36021	V36022	V36023	V36024	V36025	V36026	V36027

The Table below applies to the DL250–1 or DL260 expansion base 2.

Expansion Base D2–CM #2: Analog Output Module Slot-Dependent V-memory Locations								
Slot	0	1	2	3	4	5	6	7
No. of Channels	V36100	V36101	V36102	V36103	V36104	V36105	V36106	V36107
Storage Pointer	V36120	V36121	V36122	V36123	V36124	V36125	V36126	V36127

The Table below applies to the DL260 CPU expansion base 3.

Expansion Base D2–CM #3: Analog Output Module Slot-Dependent V-memory Locations								
Slot	0	1	2	3	4	5	6	7
No. of Channels	V36200	V36201	V36202	V36203	V36204	V36205	V36206	V36207
Storage Pointer	V36220	V36221	V36222	V36223	V36224	V36225	V36226	V36227

The Table below applies to the DL260 CPU expansion base 4.

Expansion Base D2–CM #4: Analog Output Module Slot-Dependent V-memory Locations								
Slot	0	1	2	3	4	5	6	7
No. of Channels	V36300	V36301	V36302	V36303	V36304	V36305	V36306	V36307
Storage Pointer	V36320	V36321	V36322	V36323	V36324	V36325	V36326	V36327

**Writing Data (Multiplexing)**

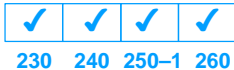

Since all channels are multiplexed into a single data word, the control program can be setup to determine which channel to write. Since the module appears as Y output points to the CPU, it is very easy to use the channel selection outputs to determine which channel to update.

Note, this example is for a module installed as shown in the previous examples. The addresses used would be different if the module was used in a different slot. You can place these rungs anywhere in the program or if you are using stage programming, place them in a stage that is always active.

This example is a two-channel multiplexer that updates each channel on alternate scans. Relay SP7 is a special relay that is on for one scan, then off for one scan.

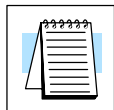

**NOTE:** You must send binary data to the module. If the data is already in binary format, you should not use the BIN instruction shown in this example.

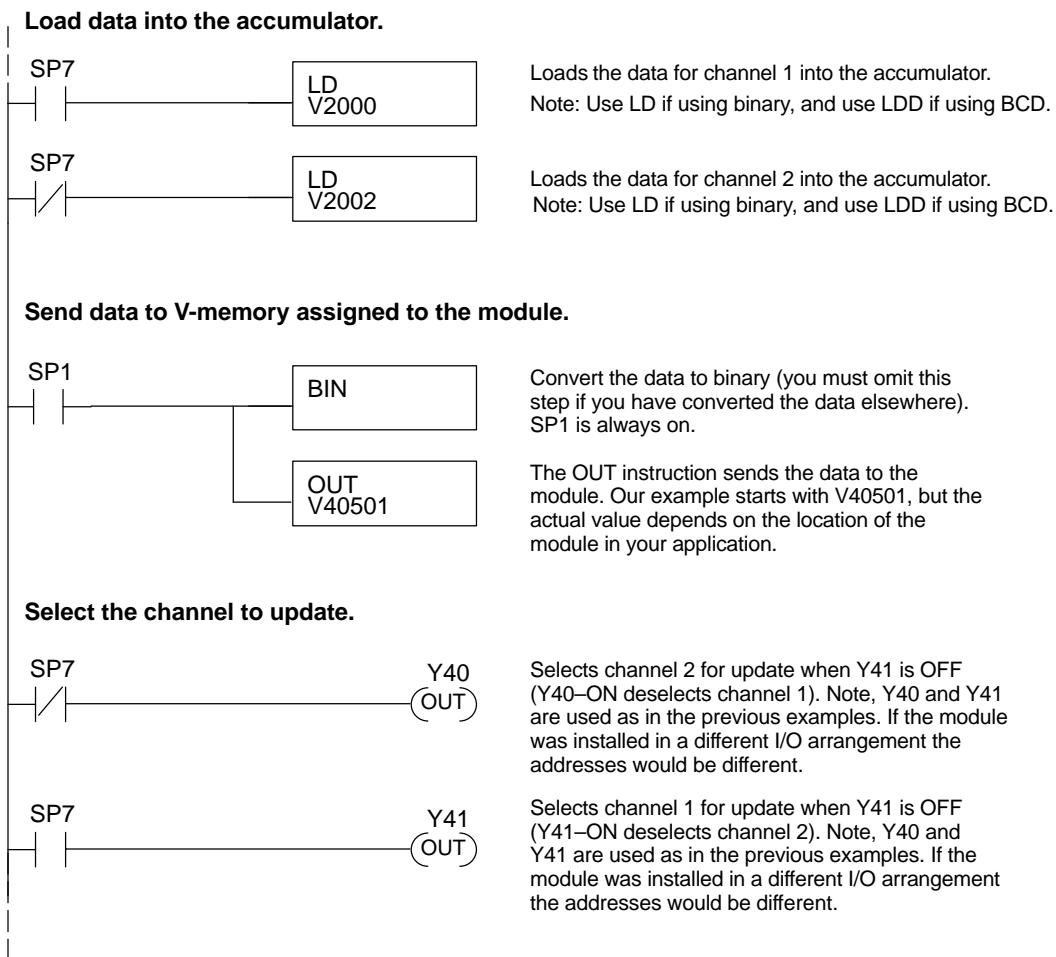

### Sending Data to One Channel

If you are not using both channels, or if you want to control the updates separately, use the following program.

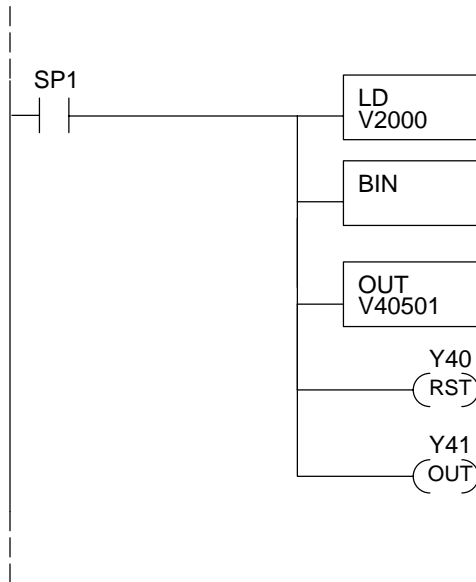

The LD instruction loads the data into the accumulator. Since SP1 is used, this rung automatically executes on every scan. You could also use an X, C, etc. permissive contact.

Note: Use LD if using binary, and use LDD if using BCD.

The BIN instruction converts the accumulator data to binary (you must omit this step if you have already converted the data elsewhere).

The OUT instruction sends the data to the module. Our example starts with V40501, but the actual value depends on the location of the module in your application.

Y40-OFF selects channel 1 for updating.

Y41-ON deselects channel 2 (do not update).

### Sending the Same Data to Both Channels

If both channel selection outputs are off, both channels will be updated with the same data.

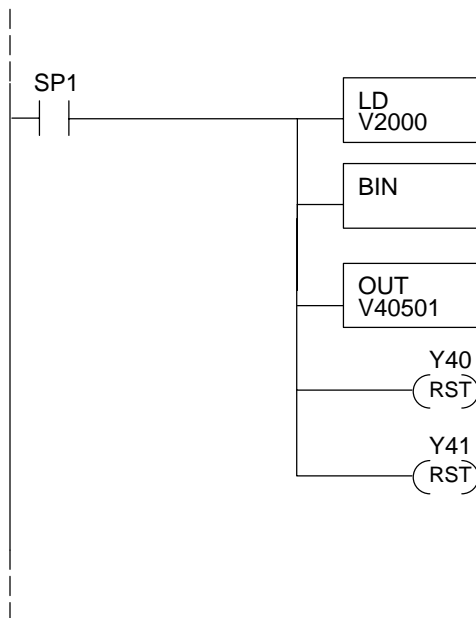

The LD instruction loads the data into the accumulator. Since SP1 is used, this rung automatically executes on every scan. You could also use an X, C, etc. permissive contact.

Note: Use LD if using binary, and use LDD if using BCD.

The BIN instruction converts the accumulator data to binary (you must omit this step if you have already converted the data elsewhere).

The OUT instruction sends the data to the module. Our example starts with V40501, but the actual value depends on the location of the module in your application.

Y40-OFF selects channel 1 for updating.

Y41-OFF selects channel 2 for updating.

### Analog and Digital Value Conversions

Sometimes it is useful to be able to quickly convert between the signal levels and the digital values. This is especially helpful during machine startup or troubleshooting. The following table provides formulas to make this conversion easier. Remember, if you imbed the sign information into the data value, you must adjust the formulas accordingly.

Range	If you know the digital value ...	If you know the signal level ...
4 to 20mA	$A = \frac{16D}{65535} + 4$	$D = \frac{65535}{16}(A - 4)$

For example, if you know you need a 10mA signal to achieve the desired result, you can easily determine the digital value that should be used.

$$D = \frac{65535}{16}(A - 4)$$

$$D = \frac{65535}{16}(10\text{mA} - 4)$$

$$D = (4095.94) (6)$$

$$D = 24575(5FFF_h)$$

# **F2-02DAS-2**

## **0–5, 0–10V 2-Channel Isolated Output**

---

In This Chapter. . . .

- Module Specifications
  - Setting the Module Jumpers
  - Connecting the Field Wiring
  - Module Operation
  - Writing the Control Program
-

## Module Specifications

The F2-02DAS-2 Analog Output module provides several hardware features:

- Supports D2-230, D2-240, DL250-1 and D2-260 CPUs (see firmware requirements below).
- Analog outputs are isolated from channel to channel and channel to PLC logic.
- The module has a removable terminal block so the module can be easily removed or changed without disconnecting the wiring.
- Can update both channels in one scan (D2-240/D2-250-1/260 only)
- Outputs are sourced through external loop supply

### Firmware Requirements:

To use this module, D2-230 CPUs must have firmware version 2.7 or later. To use the pointer method of writing values, D2-240 CPUs require firmware version 3.0 or later and D2-250 CPUs require firmware version 1.33 or later.

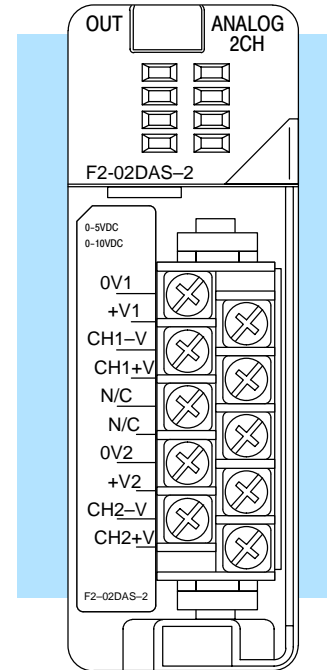

F2-02DAS-2

The following tables provide the specifications for the F2-02DAS-2 Isolated Analog Output Module. Review these specifications to make sure the module meets your application requirements.

### Output Specifications

Number of Channels	2, isolated
Output Range	0-5VDC, 0-10VDC
Resolution	16 bit (1 in 65536)
Isolation Voltage	±750V continuous, channel to channel, channel to logic
Load Impedance	2KΩ Min
Linearity Error (end to end)	± 10 counts (± 0.015% of full scale) maximum
Conversion Settling time	3ms to 0.1% of full scale
Full Scale Calibration Error	± 32 counts (± 0.05%)
Offset Calibration Error	± 13 counts (± 0.02%)
Maximum Inaccuracy	± 0.07% @ 25°C (77°F) ± 0.18% @ 0 to 60°C (32 to 140°F)

### General Specifications

PLC Update Rate	1 channel per scan maximum (Multiplexing) 2 channels per scan maximum (Pointer [DL240/DL250-1/DL260 only])
Digital outputs Output points required	16 binary data bits, 2 channel ID bits; 32 point (Y) output module
Power Budget Requirement	60 mA @ 5 VDC (supplied by base)
External Power Requirement	21.6-26.4 VDC @ 60 mA
Operating Temperature	0 to 60° C (32 to 140° F)
Storage Temperature	-20 to 70° C (-4 to 158° F)
Relative Humidity	5 to 95% (non-condensing)
Environmental air	No corrosive gases permitted
Vibration	MIL STD 810C 514.2
Shock	MIL STD 810C 516.2
Noise Immunity	NEMA ICS3-304

One count in the specification table is equal to one least significant bit of the analog data value (1 in 65536).

### Analog Output Configuration Requirements

The F2-02DAS-2 analog output requires 32 discrete output points. The module can be installed in any slot of a DL205 system, but the available power budget and discrete I/O points can be limiting factors. Check the user manual for your particular model of CPU and I/O base for more information regarding power budget and number of local, local expansion or remote I/O points.

### Special Placement Requirements (DL230 and Remote I/O Bases)

Even though the module can be placed in any slot, it is important to examine the configuration if you are using multiplexing ladder. As you can see in the section on writing the program, you use V-memory locations to send the analog data. If you place the module so that the output points do not start on a V-memory boundary, the instructions cannot access the data. This also applies when module is placed in remote base (D2-RSSS in CPU slot).

#### Correct!

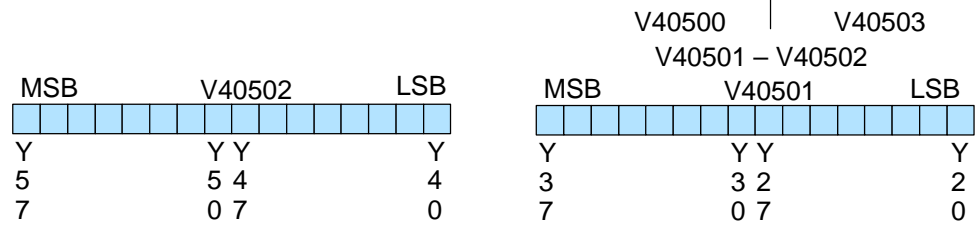
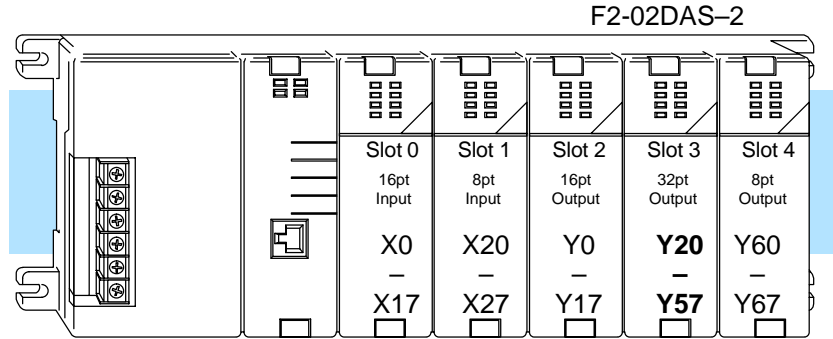

#### Incorrect

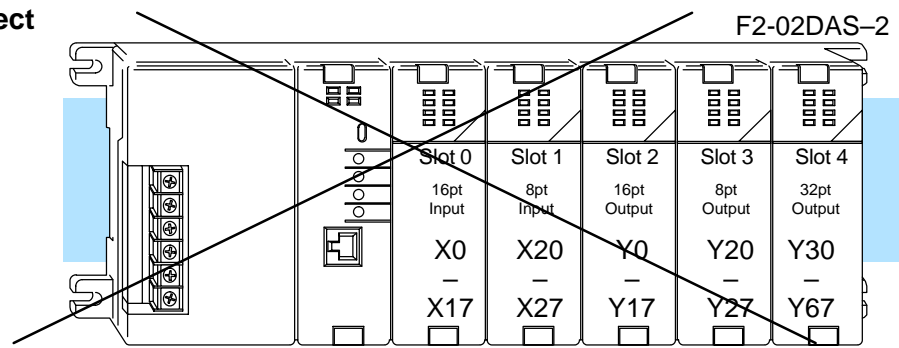

Data is split over three locations, so instructions cannot access data from a D2-230 (or when module is placed in a remote base).

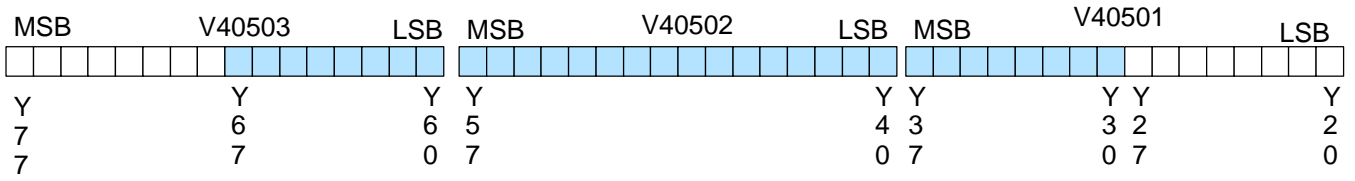

To use the required V-memory references, the *first* output address assigned to the module must be one of the following Y locations. The table also shows the V-memory addresses that correspond to these Y locations.

<b>Y</b>	Y0	Y20	Y40	Y60	Y100	Y120	Y140	Y160
<b>V</b>	V40500	V40501	V40502	V40503	V40504	V40505	V40506	V40507

F2-02DAS-2  
2-ch. Iso. Voltage Output

## Setting the Module Jumpers

The F2-02DAS-2 Analog Output module uses jumpers for selecting the voltage range for each channel. The range of each channel can be independently set. The available operating ranges are 0-5V and 0-10V.

There is one jumper for each channel. They are on the top board near the user connector side. Install or remove these jumpers to select the desired range. Unused jumpers can be stored on a single pin so they do not get lost. The module comes from the factory set for the 0-5V range.



**NOTE:** It is important to set the module jumpers correctly. The module will not operate correctly if the jumpers are not properly set for the desired voltage range.

This figure shows the jumper locations.

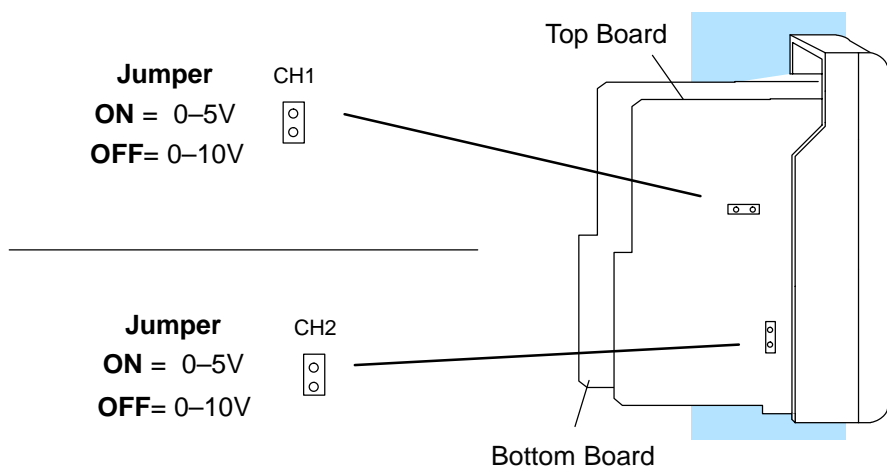

# Connecting the Field Wiring

## Wiring Guidelines

Your company may have guidelines for wiring and cable installation. If so, you should check those before you begin the installation. Here are some general things to consider:

- Use the shortest wiring route whenever possible.
- Use shielded wiring and ground the shield at the signal source. *Do not* ground the shield at both the module and the load.
- Do not run the signal wiring next to large motors, high current switches, or transformers. This may cause noise problems.
- Route the wiring through an approved cable housing to minimize the risk of accidental damage. Check local and national codes to choose the correct method for your application.

## Transmitter Power Supply Requirements

The F2-02DAS-2 requires a separate transmitter power supply. Each channel requires 21.6-26.4 VDC at 60 mA per channel.



**WARNING:** If you are using 24 VDC power from the base, make sure you calculate the power budget. Exceeding the power budget can cause unpredictable system operation that can lead to a risk of personal injury or damage to equipment.

## Wiring Diagram

The F2-02DAS-2 module has a removable connector to make wiring easier. Simply squeeze the top and bottom retaining clips and gently pull the connector from the module. Use the following diagram to connect the field wiring.

NOTE 1: Shields should be connected to the 0V.  
 NOTE 2: Load must be within compliance voltage.  
 NOTE 3: For non-isolated outputs, connect 0V1 to 0V2.

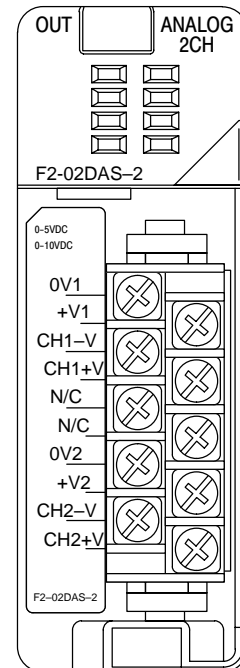
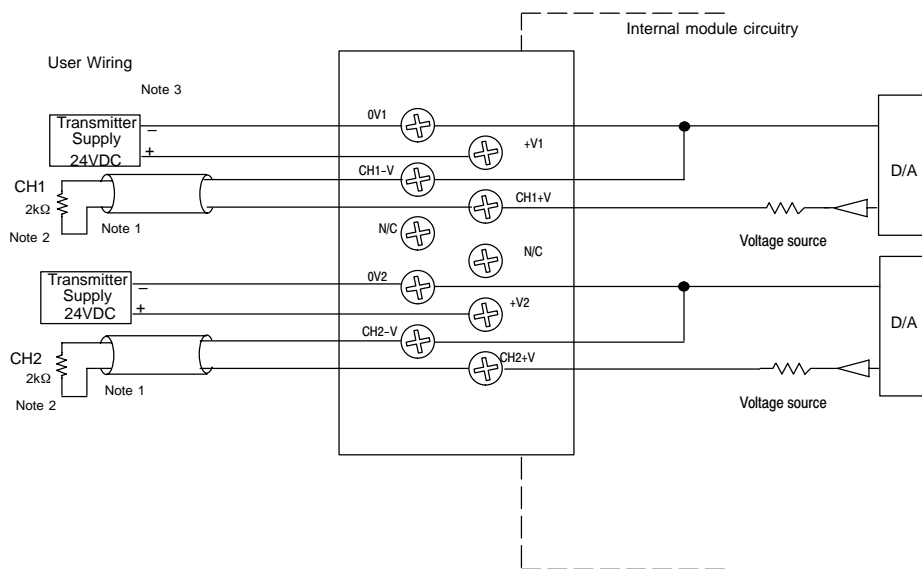

F2-02DAS-2 2-ch. Iso. Voltage Output

## Module Operation

### Channel Update Sequence for a DL230 CPU (Multiplexing)

Before you begin writing the control program, it is important to take a few minutes to understand how the module processes and represents the analog signals.

If you are using multiplexing ladder, you can send one channel of data to the output module on each scan. The module refreshes both field devices on each scan, but you can only get new data from the CPU at the rate of one channel per scan. Since there are two channels, it can take two scans to update both channels. However, if you are only using one channel, then you can update that channel on every scan. The multiplexing method can also be used for DL240/250-1/260 CPUs.

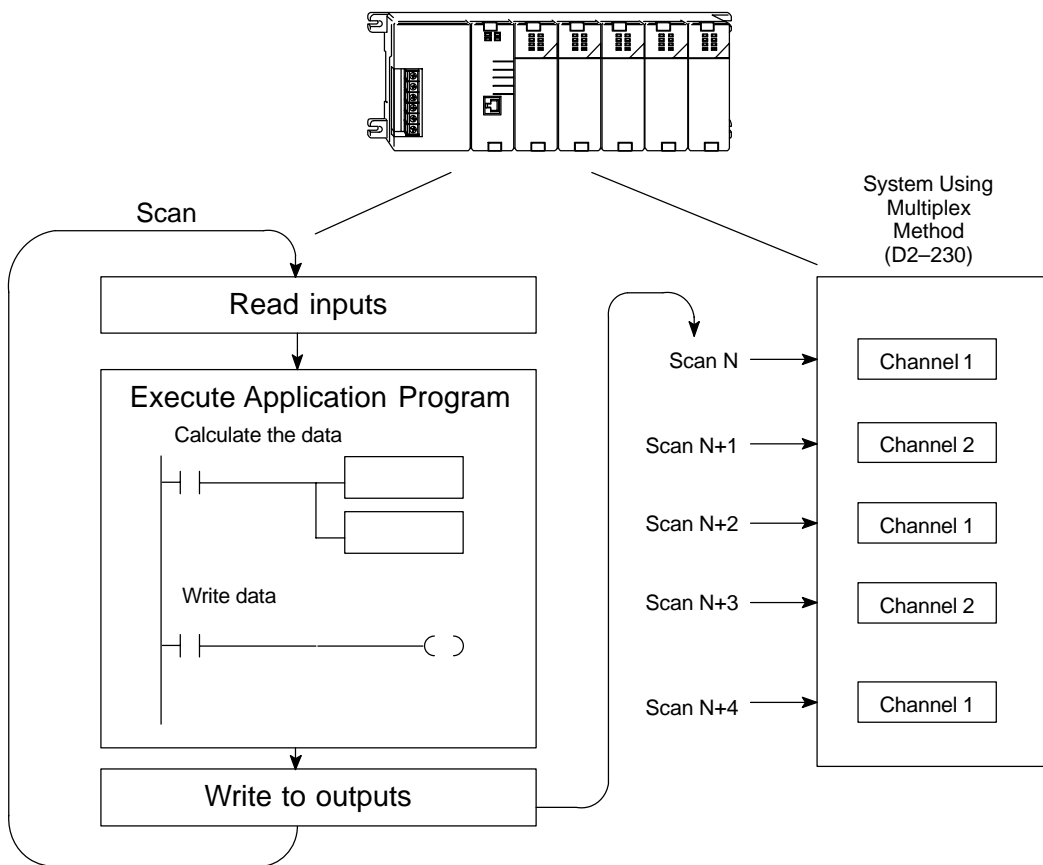

F2-02DAS-2  
2-ch. Iso. Voltage Output

**Channel Update Sequence for a DL240, DL250-1 or DL260 CPU (Pointer Method)**

If you are using pointers (Pointer Method), you can update both channels on every scan. This is because the D2-240, D2-250-1 and D2-260 CPUs support special V-memory locations that are used to manage the data transfer. This is discussed in more detail in the section on Writing the Control Program.

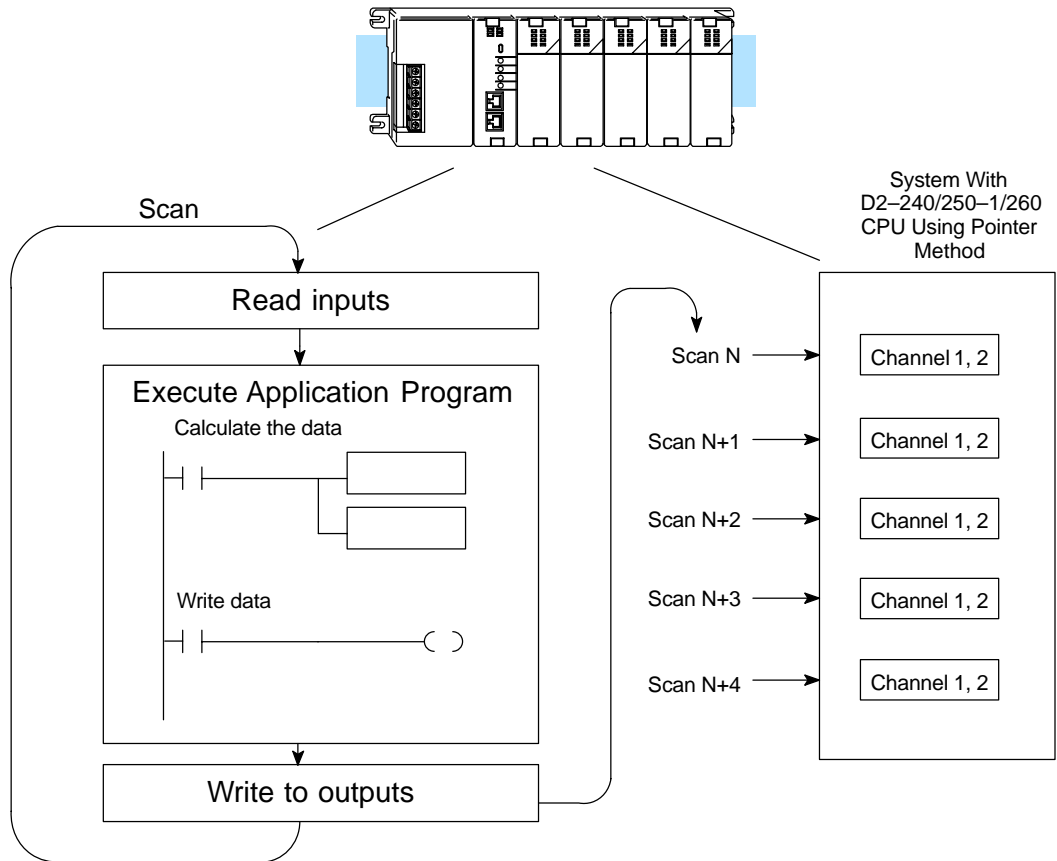

**Understanding the Output Assignments**

You may recall the F2-02DAS-2 module appears to the CPU as a 32-point discrete output module. These points provide the data value and an indication of which channel to update. Note, if you are using a D2-240/250-1/260 CPU, you may never have to use these bits, but it may help you understand the data format. Since all output points are automatically mapped into V-memory, it is very easy to determine the location of the data word that will be assigned to the module.

F2-02DAS-2  
2-ch. Iso. Voltage Output

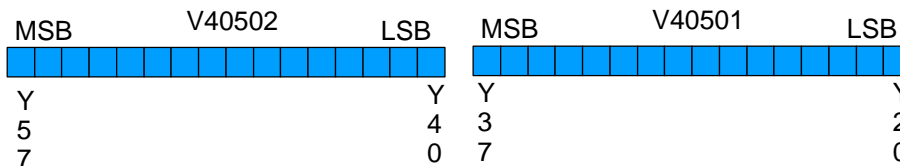
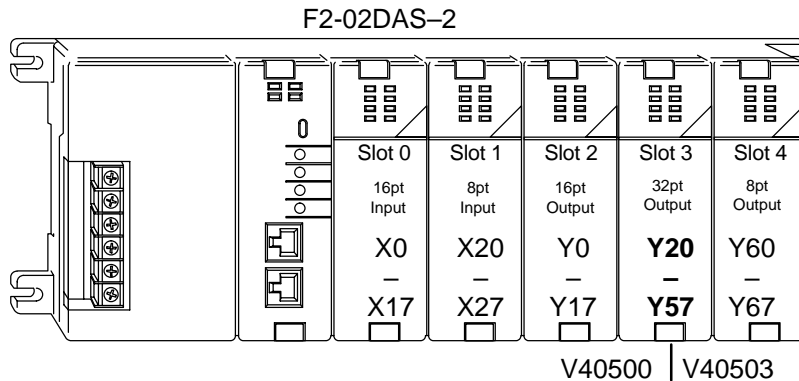

Within this word location, the individual bits represent specific information about the analog signal.

**Channel Select Outputs**

Two of the outputs select the active channel. Remember, the V-memory bits are mapped directly to discrete outputs. Turning a bit OFF selects its channel. By controlling these outputs, you can select which channel(s) gets updated.

Y41	Y40	Channel
On	Off	1
Off	On	2
Off	Off	1 & 2 (same data to both channels)
On	On	none (both channels hold current values)

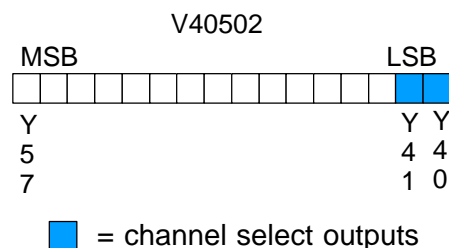

**Analog Data Bits**

The first sixteen bits represent the analog data in binary format.

Bit	Value	Bit	Value
0	1	8	256
1	2	9	512
2	4	10	1024
3	8	11	2048
4	16	12	4096
5	32	13	8192
6	64	14	16384
7	128	15	32768

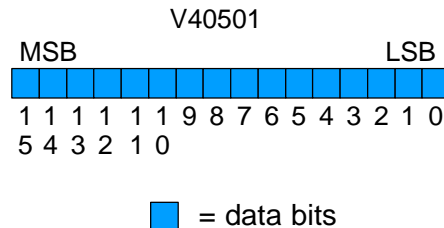

F2-02DAS-2  
2-ch. Iso. Voltage Output

### Module Resolution

Since the module has 16-bit resolution, the analog signal is converted into 65536 counts ranging from 0 – 65535 ( $2^{16}$ ). For example, send a 0 to get a 0V signal and 65535 to get a 10V signal. This is equivalent to a binary value of 0000 0000 0000 0000 to 1111 1111 1111 1111, or 0000 to FFFF hexadecimal. The diagram shows how this relates to the signal range.

Each count can also be expressed in terms of the signal level by using the equation shown.

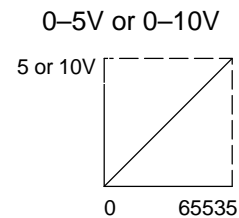

$$\text{Resolution} = \frac{H - L}{65535}$$

H = high limit of the signal range

L = low limit of the signal range

# Writing the Control Program

## Calculating the Digital Value

Your program must calculate the digital value to send to the analog module. There are many ways to do this, but most applications are understood more easily if you use measurements in engineering units. This is accomplished by using the conversion formula shown.

You may have to make adjustments to the formula depending on the scale you choose for the engineering units.

$$A = U \frac{65535}{H - L}$$

A = Analog value (0 – 65535)

U = Engineering Units

H = high limit of the engineering unit range

L = low limit of the engineering unit range

Consider the following example which controls pressure from 0.0 to 99.9 PSI. By using the formula, you can easily determine the digital value that should be sent to the module. The example shows the conversion required to yield 49.4 PSI. Notice the formula uses a multiplier of 10. This is because the decimal portion of 49.4 cannot be loaded, so you adjust the formula to compensate for it.

$$A = 10U \frac{65535}{10(H - L)}$$

$$A = 494 \frac{65535}{1000 - 0}$$

$$A = 32374$$

## Engineering Units Conversion

The example program shows how you would write the program to perform the engineering unit conversion to output data formats 0 – 65535 when using a D2-250 CPU. This example assumes you have calculated or loaded the engineering unit values in BCD format and stored it in V2300 for channel 1.

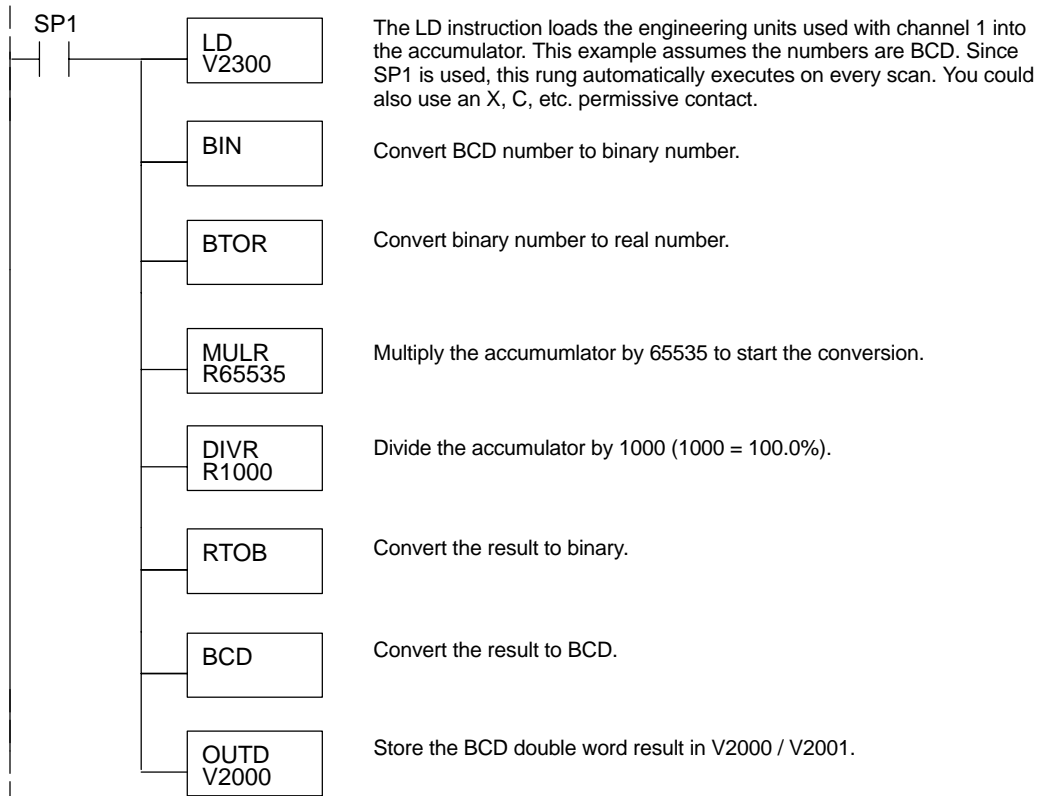

F2-02DAS-2  
2-ch. Iso. Voltage Output

### Reading Values: Pointer Method and Multiplexing

There are two methods of reading values:

- The pointer method
- Multiplexing

You can use either method when using D2-240, D2-250-1 and D2-260 CPUs, but for ease of programming it is strongly recommended that you use the pointer method. You must use the multiplexing method with remote I/O modules (the pointer method will not work).

### Pointer Method

✗	✓	✓	✓
230	240	250-1	260

Once you have calculated the data values (shown previously) you have to enter the program that actually updates the module. The D2-240/250-1/260 has special V-memory locations assigned to each base slot that greatly simplify the programming requirements. By using these V-memory locations you can:

- specify the number of channels to update.
- specify where to obtain the output data.



**NOTE:** D2-240 CPUs with firmware version 3.0 and D2-250 CPUs with version 1.33 or later support this method.

The following program example shows how to set up these locations. Place this rung anywhere in the ladder program, or in the initial stage when using stage programming. You may recall in the previous examples we had used V2000 and V2001 to store the calculated values. Also, in the previous examples we had the analog module installed in slot 3. You should use the appropriate memory locations for your application. The pointer method automatically converts values to binary.

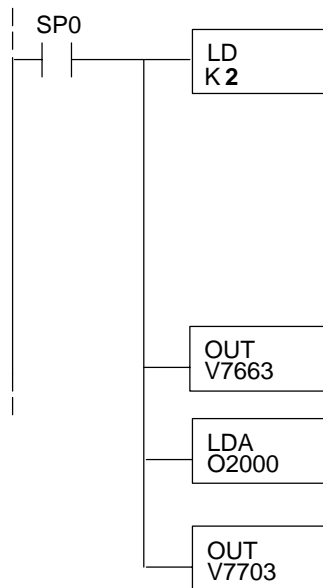

- or -

Loads a constant that specifies the number of channels to scan and the data format. The lower byte, most significant nibble (MSN) selects the data format (i.e. 0=BCD, 8=Binary), the LSN selects the number of channels (1 or 2).

The binary format is used for displaying data on some operator interfaces. The D2-230/240 CPUs do not support binary math functions, whereas the D2-250 does.

Special V-memory location assigned to slot 3 that contains the number of channels to scan.

This loads an octal value for the first V-memory location that will be used to store the output data. For example, the O2000 entered here would designate the following addresses.  
Ch1 - V2000, Ch2 - V2002

The octal address (O2000) is stored here. V7703 is assigned to slot 3 and acts as a pointer, which means the CPU will use the octal value in this location to determine exactly where to store the output data.

The tables below show the special V-memory locations used by the DL240, DL250-1 and DL260 for the CPU base and local expansion base I/O slots. Slot 0 (zero) is the module next to the CPU or D2-CM module. Slot 1 is the module two places from the CPU or D2-CM, and so on. Remember, the CPU only examines the pointer values at these locations after a mode transition. Also, if you use the DL230 (multiplexing) method, verify that these addresses in the CPU are zero.

The Table below applies to the DL240, DL250-1 and DL260 CPU base.

CPU Base: Analog Output Module Slot-Dependent V-memory Locations								
Slot	0	1	2	3	4	5	6	7
No. of Channels	V7660	V7661	V7662	V7663	V7664	V7665	V7666	V7667
Storage Pointer	V7700	V7701	V7702	V7703	V7704	V7705	V7706	V7707

The Table below applies to the DL250-1 or DL260 expansion base 1.

Expansion Base D2-CM #1: Analog Output Module Slot-Dependent V-memory Locations								
Slot	0	1	2	3	4	5	6	7
No. of Channels	V36000	V36001	V36002	V36003	V36004	V36005	V36006	V36007
Storage Pointer	V36020	V36021	V36022	V36023	V36024	V36025	V36026	V36027

The Table below applies to the DL250-1 or DL260 expansion base 2.

Expansion Base D2-CM #2: Analog Output Module Slot-Dependent V-memory Locations								
Slot	0	1	2	3	4	5	6	7
No. of Channels	V36100	V36101	V36102	V36103	V36104	V36105	V36106	V36107
Storage Pointer	V36120	V36121	V36122	V36123	V36124	V36125	V36126	V36127

The Table below applies to the DL260 CPU expansion base 3.

Expansion Base D2-CM #3: Analog Output Module Slot-Dependent V-memory Locations								
Slot	0	1	2	3	4	5	6	7
No. of Channels	V36200	V36201	V36202	V36203	V36204	V36205	V36206	V36207
Storage Pointer	V36220	V36221	V36222	V36223	V36224	V36225	V36226	V36227

The Table below applies to the DL260 CPU expansion base 4.

Expansion Base D2-CM #4: Analog Output Module Slot-Dependent V-memory Locations								
Slot	0	1	2	3	4	5	6	7
No. of Channels	V36300	V36301	V36302	V36303	V36304	V36305	V36306	V36307
Storage Pointer	V36320	V36321	V36322	V36323	V36324	V36325	V36326	V36327

### Writing Data (Multiplexing)



Since all channels are multiplexed into a single data word, the control program can be setup to determine which channel to write. Since the module appears as Y output points to the CPU, it is very easy to use the channel selection outputs to determine which channel to update.

Note, this example is for a module installed as shown in the previous examples. The addresses used would be different if the module was used in a different slot. You can place these rungs anywhere in the program or if you are using stage programming, place them in a stage that is always active.

This example is a two-channel multiplexer that updates each channel on alternate scans. Relay SP7 is a special relay that is on for one scan, then off for one scan.



**NOTE:** You must send binary data to the module. If the data is already in binary format, you should not use the BIN instruction shown in this example.

#### Load data into the accumulator.

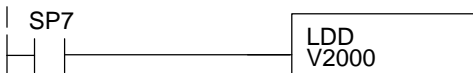

Loads the data for channel 1 into the accumulator.  
Note: Use LD if using binary, and use LDD if using BCD.

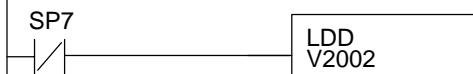

Loads the data for channel 2 into the accumulator.  
Note: Use LD if using binary, and use LDD if using BCD.

#### Send data to V-memory assigned to the module.

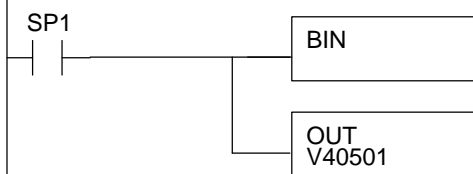

Convert the data to binary (you must omit this step if you have converted the data elsewhere). SP1 is always on.

The OUT instruction sends the data to the module. Our example starts with V40501, but the actual value depends on the location of the module in your application.

#### Select the channel to update.



Selects channel 2 for update when Y41 is OFF (Y40-ON deselects channel 1). Note, Y40 and Y41 are used as in the previous examples. If the module was installed in a different I/O arrangement the addresses would be different.



Selects channel 1 for update when Y40 is OFF (Y41-ON deselects channel 2). Note, Y40 and Y41 are used as in the previous examples. If the module was installed in a different I/O arrangement the addresses would be different.

**Sending Data to One Channel**

If you are not using both channels, or if you want to control the updates separately, use the following program.

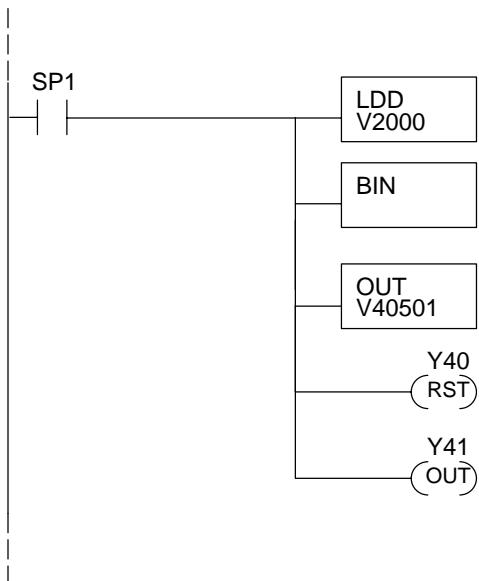

The LD instruction loads the data into the accumulator. Since SP1 is used, this rung automatically executes on every scan. You could also use an X, C, etc. permissive contact.

Note: Use LD if using binary, and use LDD if using BCD.

The BIN instruction converts the accumulator data to binary (you must omit this step if you have already converted the data elsewhere).

The OUT instruction sends the data to the module. Our example starts with V40501, but the actual value depends on the location of the module in your application.

Y40-OFF selects channel 1 for updating.

Y41-ON deselects channel 2 (do not update).

**Sending the Same Data to Both Channels**

If both channel selection outputs are off, both channels will be updated with the same data.

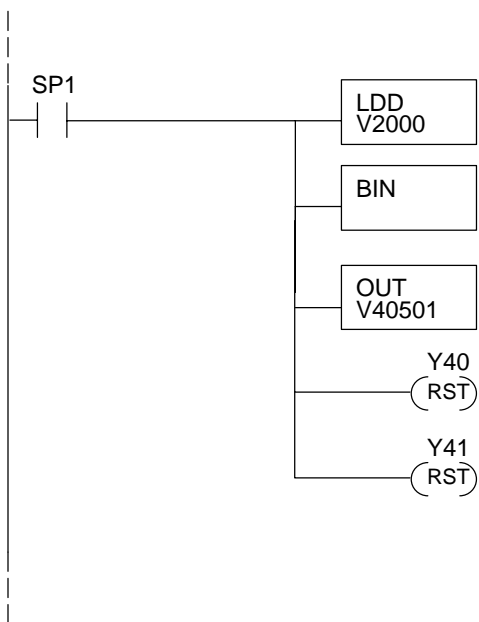

The LD instruction loads the data into the accumulator. Since SP1 is used, this rung automatically executes on every scan. You could also use an X, C, etc. permissive contact.

Note: Use LD if using binary, and use LDD if using BCD.

The BIN instruction converts the accumulator data to binary (you must omit this step if you have already converted the data elsewhere).

The OUT instruction sends the data to the module. Our example starts with V40501, but the actual value depends on the location of the module in your application.

Y40-OFF selects channel 1 for updating.

Y41-OFF selects channel 2 for updating.

F2-02DAS-2  
2-ch. Iso. Voltage Output

### Analog and Digital Value Conversions

Sometimes it is useful to be able to quickly convert between the signal levels and the digital values. This is especially helpful during machine startup or troubleshooting. The following table provides formulas to make this conversion easier. Remember, if you imbed the sign information into the data value, you must adjust the formulas accordingly.

Range	If you know the digital value ...	If you know the signal level ...
0-5 VDC	$A = \frac{5D}{65535}$	$D = \frac{65535}{5}A$
0-10 VDC	$A = \frac{10D}{65535}$	$D = \frac{65535}{10}A$

For example, if you know you need a 4V signal to achieve the desired result, you can easily determine the digital value that should be used.

$$D = \frac{65535}{5}A$$

$$D = \frac{65535}{5}(4)$$

$$D = (13107)(4)$$

$$D = 52428(\text{CCCC}_h)$$

# **F2-4AD2DA**

## **4-Ch. In / 2-Ch. Out Combination Analog**

---

In This Chapter. . . .

- Module Specifications
  - Connecting the Field Wiring
  - Module Operation
  - Writing the Control Program
-

## Module Specifications

The F2-4AD2DA Analog Input/Output module provides several hardware features:

- On-board 250 ohm, 1/2 watt precision resistors provide substantial over-current-protection for 4–20mA current loops.
- Analog inputs and outputs are optically isolated from the PLC logic.
- The module has a removable terminal block so the module can be easily removed or changed without disconnecting the wiring.
- With a DL240/250–1/260 CPU, you can update all input and output channels in one scan.
- On-board active analog filtering and RISC-like microcontroller provide digital signal processing to maintain precision analog measurements in noisy environments.
- Low-power CMOS design requires less than 80mA from an external 18–26.4 VDC power supply.

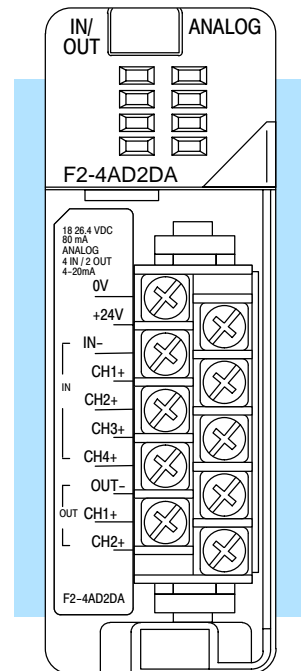

The following tables provide the specifications for the F2-4AD2DA Analog Input/Output Module. Review these specifications to make sure the module meets your application requirements.

### Input Specifications

Number of Input Channels	4, single ended (one common)
Range	4 to 20 mA current
Resolution	12 bit (1 in 4096)
Input Impedance	250Ω, ±0.1%, 1/2W, 25ppm/°C current input resistance
Maximum Continuous Overload	–40 to +40 mA, each current input
Input Stability	± 1 count
Crosstalk	–70 dB, 1 count maximum
Common Mode Rejection	–50 dB at 800 Hz
Active Low-Pass Filter	–3 dB at 50Hz, 2 poles (–12 dB per octave)
Step Response	10 mS to 95%
Full Scale Calibration Error	± 12 counts maximum, at 20 mA current input
Offset Calibration Error	± 8 counts maximum, at 4 mA current input
Maximum Input Inaccuracy	± 0.3% @ 25°C (77°F) ± 0.45% @ 0 to 60°C (32 to 140°F)
Recommended External Fuse	0.032A, series 217 fast-acting, current inputs

**Output Specifications**

Number of Output Channels	2, single ended (one common)
Range	4 to 20 mA current
Resolution	12 bit (1 in 4096)
Peak Withstanding Voltage	75 VDC, current outputs
External Load Resistance	0 $\Omega$ minimum, current outputs
Loop Supply Voltage Range	18–30VDC, current outputs
Maximum Load / Power Supply	910 $\Omega$ /24V, 620 $\Omega$ /18V, 1200 $\Omega$ /30V, current outputs
Linearity Error (best fit)	$\pm 1$ count ( $\pm 0.025\%$ of full scale) maximum
Settling Time	100 $\mu$ s maximum (full scale change)
Maximum Inaccuracy	$\pm 0.1\%$ @ 25°C (77°F) $\pm 0.3\%$ @ 0 to 60°C (32 to 140°F)
Full Scale Calibration Error	$\pm 5$ counts at 20 mA current output
Offset Calibration Error	$\pm 3$ counts at 4 mA current output

**General Module Specifications**

Digital Input and Output Points Required	16 point (X) inputs 16 point (Y) outputs
PLC Update Rate	4 input channels per scan maximum (D2–240/250–1/260 CPU) 2 output channels per scan maximum (D2–240/250–1/260 CPU) 1 input and 1 output channel per scan maximum (D2–230 CPU)
Power Budget Requirement	60 mA @ 5 VDC (supplied by base)
External Power Supply Requirement	18 to 26.4 VDC, 80 mA maximum plus 20 mA per loop output
Accuracy vs. Temperature	$\pm 45$ ppm/°C full scale calibration range (including maximum offset change)
Operating Temperature	0 to 60° C (32 to 140° F)
Storage Temperature	–20 to 70° C (–4 to 158° F)
Relative Humidity	5 to 95% (non-condensing)
Environmental Air	No corrosive gases permitted
Vibration	MIL STD 810C 514.2
Shock	MIL STD 810C 516.2
Noise Immunity	NEMA ICS3–304

One count in the specification table is equal to one least significant bit of the analog data value (1 in 4096).

**Combination Analog Configuration Requirements**

The F2-4AD2DA Analog module requires 16 discrete input and 16 discrete output points. The module can be installed in any slot of a DL205 system, except when you use the DL230 programming method. The available power budget may also be a limiting factor. Check the user manual for your particular model of CPU and I/O base for more information regarding power budget and number of local, local expansion or remote I/O points.

### Special Placement Requirements (DL230 and Remote I/O Bases)

Even though the module can be placed in any slot, it is important to examine the configuration if you are using a DL230 CPU. As you can see in the section on writing the program, you use V-memory locations to extract the analog data. If you place the module so that either the input or output points do not start on a V-memory boundary, the instructions cannot access the data. This also applies when the module is placed in remote I/O bases (D2-RSSS in CPU slot).

#### Correct!

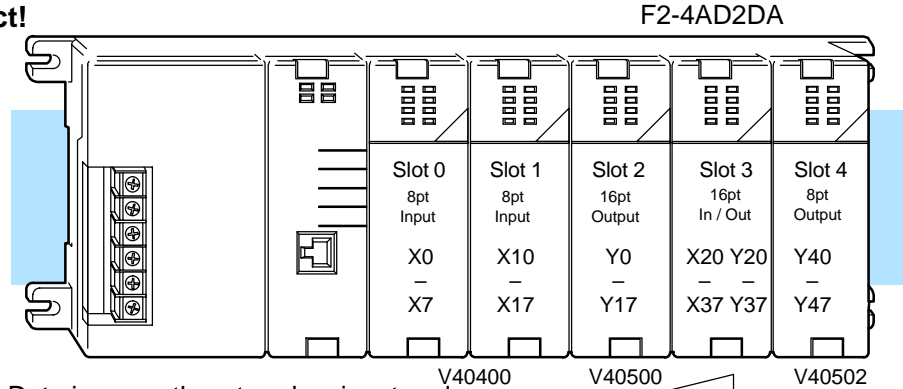

Output Data is correctly entered so input and output points start on a V-memory boundary.

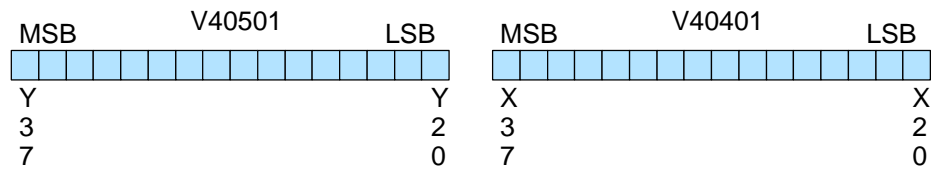

#### Incorrect

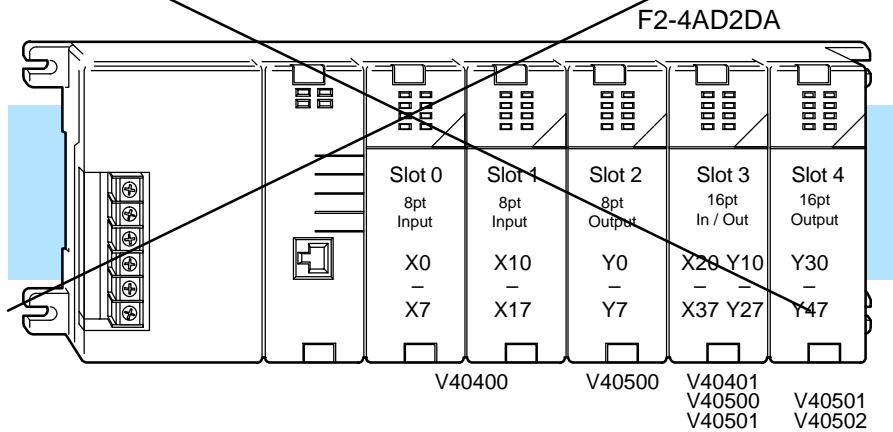

Output Data is split over two locations, so instructions cannot write data from a DL230.

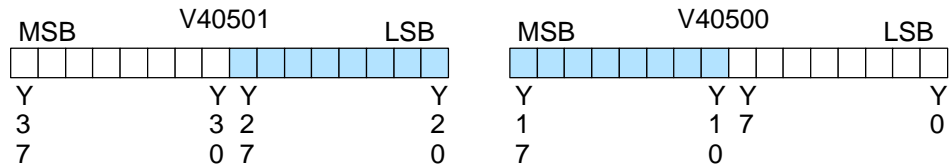

F2-4AD2DA  
4-Ch. In / 2-Ch. Out

To use the V-memory references required for a DL230 CPU, the *first* input *and* output addresses assigned to the module must be one of the following X and Y locations. The table also shows the V-memory addresses that correspond to these locations.

<b>X</b>	X0	X20	X40	X60	X100	X120	X140	X160
<b>V</b>	V40400	V40401	V40402	V40403	V40404	V40405	V40406	V40407
<b>Y</b>	Y0	Y20	Y40	Y60	Y100	Y120	Y140	Y160
<b>V</b>	V40500	V40501	V40502	V40503	V40504	V40505	V40506	V40507

## Connecting the Field Wiring

**Wiring Guidelines** Your company may have guidelines for wiring and cable installation. If so, you should check those before you begin the installation. Here are some ideas to consider:

- Use the shortest wiring route whenever possible.
- Use shielded wiring and ground the shield at the signal source. *Do not* ground the shield at both the module and the load or source.
- Do not run the signal wiring next to large motors, high current switches, or transformers. This may cause noise problems.
- Route the wiring through an approved cable housing to minimize the risk of accidental damage. Check local and national codes to choose the correct method for your application.

### User Power Supply Requirements

The F2-4AD2DA requires at least one field-side power supply. You may use the same or separate power sources for the module supply and loop supply. The module requires 18–26.4VDC, at 80 mA. In addition, each current loop requires 20 mA (a total of 120 mA for six current loops). If you want to use a separate power supply make sure that it meets these requirements.

The DL205 bases have built-in 24 VDC power supplies that provide up to 300mA of current. You may use this instead of a separate supply if you are using only one combination module. The current required is 80 mA (module) plus up to 120 mA (six current loops) for a total of 200 mA.

It is desirable in some situations to power the loops separately in a location remote from the PLC. This will work as long as the loop's power supply meets the voltage and current requirements, and its minus (–) side and the module supply's minus (–) side are connected together.

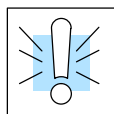

**WARNING:** If you are using the 24 VDC base power supply, make sure you calculate the power budget. Exceeding the power budget can cause unpredictable system operation that can lead to a risk of personal injury or damage to equipment.

The DL205 base has a switching type power supply. As a result of switching noise, you may notice  $\pm 3-5$  counts of instability in the analog input data if you use the base power supply. If this is unacceptable, you should try one of the following:

1. Use a separate linear power supply.
2. Connect the 24VDC common to the frame ground, which is the screw terminal marked "G" on the base.

By using these methods, the input stability is rated at  $\pm 1$  count.

### Current Loop Transmitter Impedance

Standard 4 to 20 mA transmitters and transducers can operate from a wide variety of power supplies. Not all transmitters are alike and the manufacturers often specify a minimum loop or load resistance that must be used with the transmitter.

The F2-4AD2DA provides 250 ohm resistance for each input channel. If your transmitter requires a load resistance below 250 ohms, you do not have to make any adjustments. However, if your transmitter requires a load resistance higher than 250 ohms, you need to add a resistor in series with the module.

Consider the following example for a transmitter being operated from a 30 VDC supply with a recommended load resistance of 750 ohms. Since the module has a 250 ohm resistor, you need to add an additional resistor.

Example:

$$R = Tr - Mr$$

$$R = 750 - 250$$

$$R \geq 500$$

R – resistor to add  
Tr – Transmitter total resistance requirement  
Mr – Module resistance (internal 250 ohms)

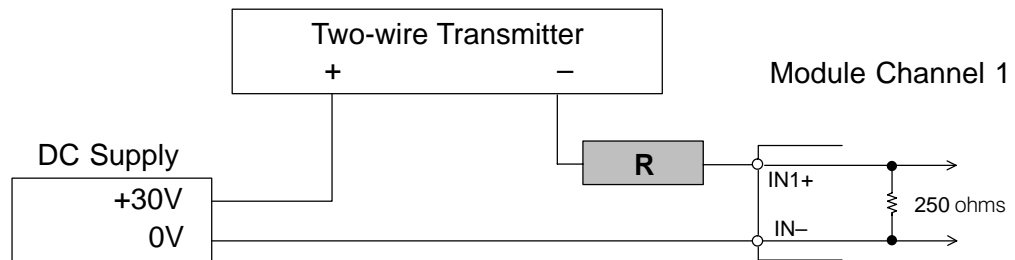

In the example, add a 500 ohm resistor (R) in series with the module.

**Wiring Diagram** The F2-04AD2DA module has a removable connector to make wiring easier. Simply squeeze the top and bottom retaining clips and gently pull the connector from the module. Use the following diagram to connect the field wiring. The diagram shows separate module and loop power supplies. If you desire to use only one field-side supply, just combine the supplies' positive (+) terminals into one node, and remove the loop supply.

Note 1: Shields should be connected at their respective signal source.

Note 2: Unused channels should remain open (no connections) for minimum power consumption.

Note 3: More than one external power supply can be used provided all the power supply commons are connected together.

Note 4: A series 217, 0.032A, fast-acting fuse is recommended for 4–20 mA current input loops.

Note 5: If the power supply common of an external power supply is not connected to 0V on the module, then the output of the external transmitter must be isolated. To avoid "ground loop" errors, recommended 4–20mA transmitter types are:

- a. For 2 or 3 wire: Isolation between input signal and power supply.
- b. For 4 wire: Isolation between input signal, power supply, and 4–20 mA output.

Note 6: If an analog channel is connected backwards, then incorrect data values will be returned for that channel. Input signals in the -4 to +4 mA range return a zero value. Signals in the -4 to -40 mA range return a non-zero value.

Note 7: To avoid small errors due to terminal block losses, connect 0V, IN– and OUT– on the terminal block as shown. The module's internal connection of these nodes is not sufficient to permit module performance up to the accuracy specifications.

Note 8: Choose a output transducer resistance according to the maximum load / power supply listed in the Output Specifications table.

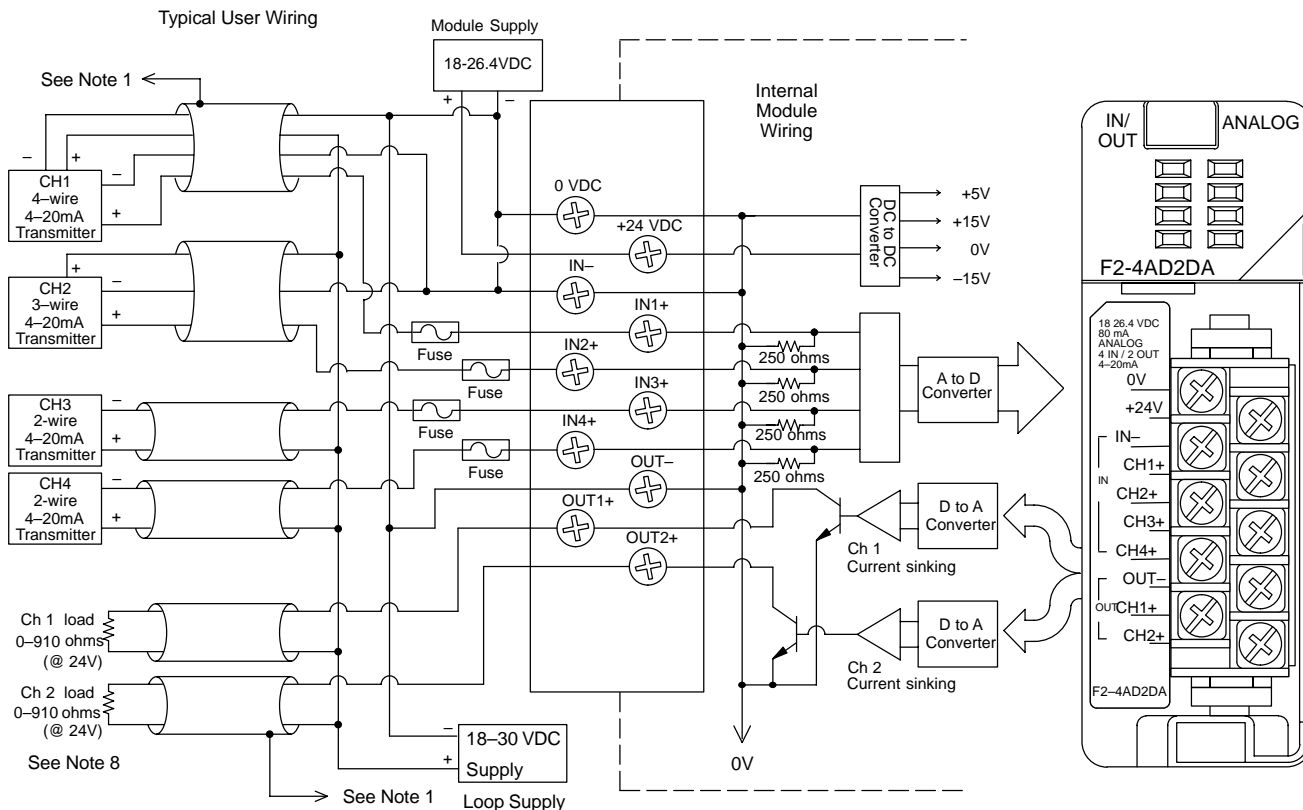

F2-4AD2DA  
4-Ch. In / 2-Ch. Out

# Module Operation

Before you begin writing the control program, it is important to take a few minutes to understand how the module processes and represents the analog signals.

The F2-4AD2DA module can supply different amounts of data per scan, depending on the type of CPU you are using. The DL230 can obtain one channel of input data per CPU scan. Since there are four channels, it can take up to four scans to get data for all channels. Once all channels have been scanned the process starts over with channel 1. Unused channels are not processed, so if you select only two channels, then each channel will be updated every other scan.

## Input Channel Scanning Sequence for a DL230 CPU (Multiplexing)

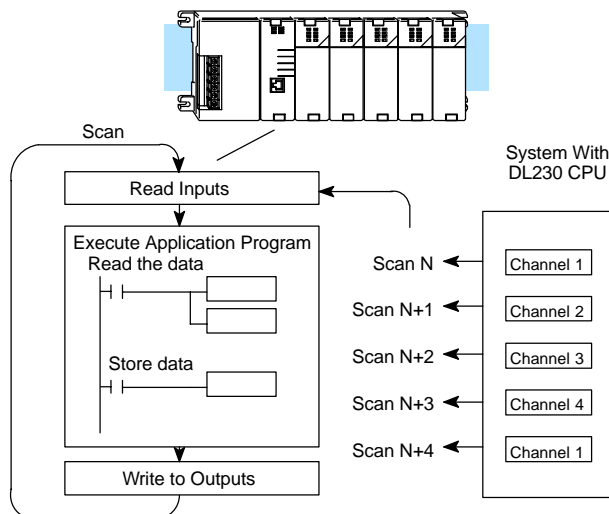

If you are using a DL240, DL250-1 or DL260 CPU, you can obtain all four channels of input data in one scan. This is because the DL240/250-1/260 CPU supports special V-memory locations that are used to manage the data transfer. This is discussed in more detail in the section on Writing the Control Program.

## Input Channel Scanning Sequence for a DL240, DL250-1 or DL260 CPU (Pointer Method)

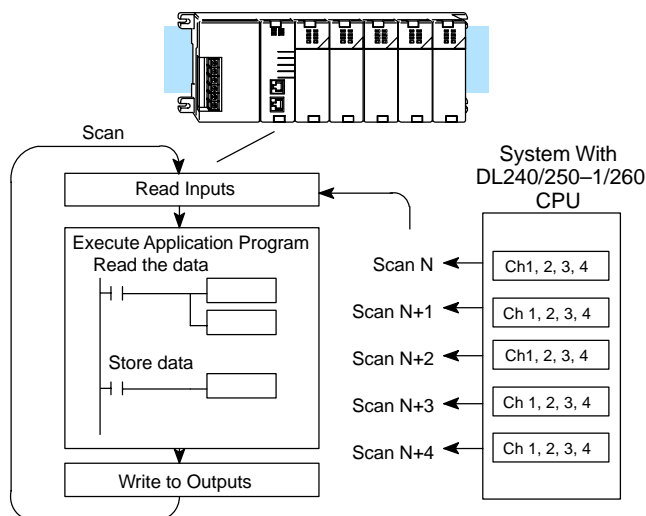

F2-4AD2DA  
4-Ch. In / 2-Ch. Out

**Output Channel Update Sequence for a DL230 CPU (Multiplexing)**

If you are using a DL230 CPU, you can send one channel of data to the output module on each scan. Since there are two channels, it can take two scans to update both channels. However, if you are only using one channel, then you can update that channel on every scan.

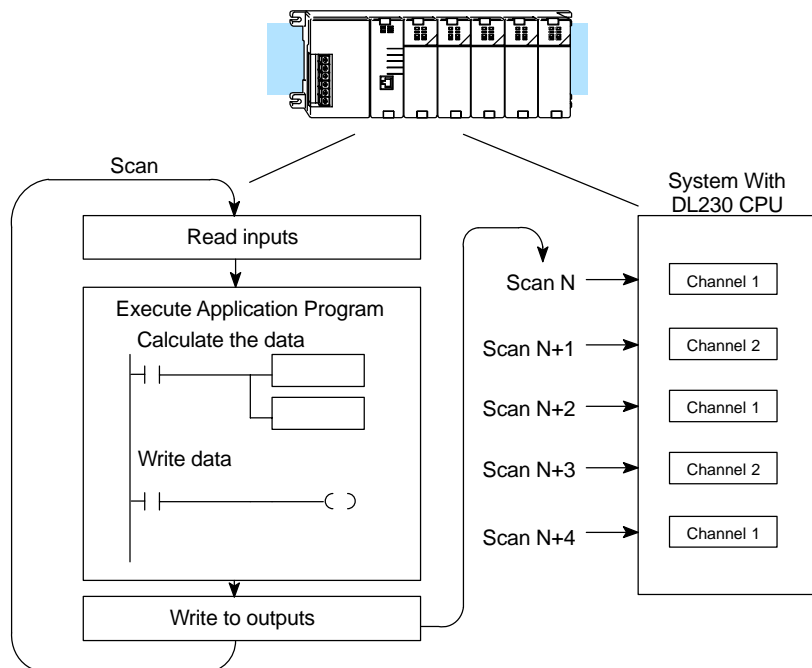

**Output Channel Update Sequence for a DL240, DL250-1 or DL260 CPU (Pointer Method)**

If you are using a DL240, DL250-1 or DL260 CPU, you can update both channels on every scan. This is because the DL240/250-1/260 CPU supports special V-memory locations that are used to manage the data transfer. This is discussed in more detail in the section on Writing the Control Program.

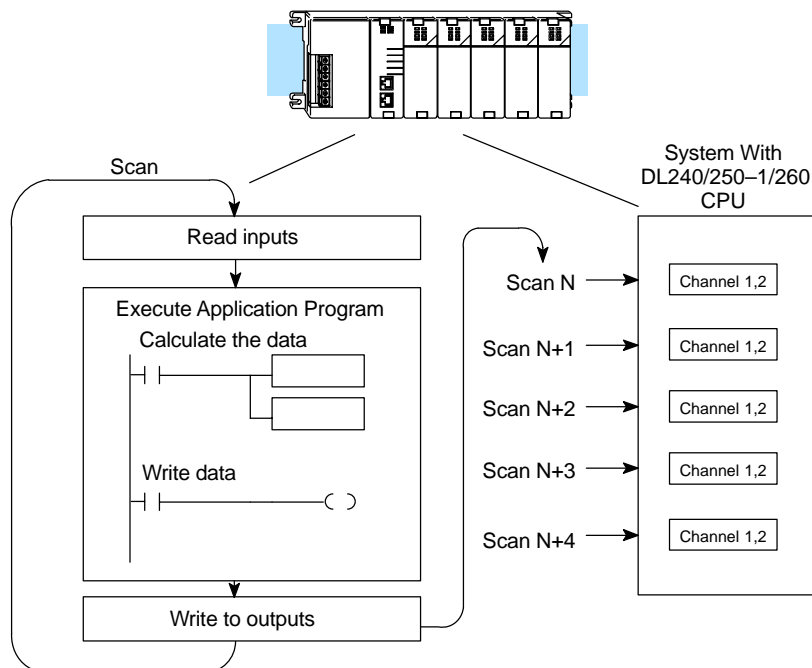

F2-4AD2DA  
4-Ch. In / 2-Ch. Out

### Understanding the I/O Assignments

You may recall the F2-4AD2DA module appears to the CPU as 16 discrete input and 16 discrete output points. These points provide the data value and channel identification. Note, if you are using a DL240/250 CPU, you may never have to use these bits, but it may help you understand the data format.

Since all output points are automatically mapped into V-memory, it is very easy to determine the location of the data words that will be assigned to the module.

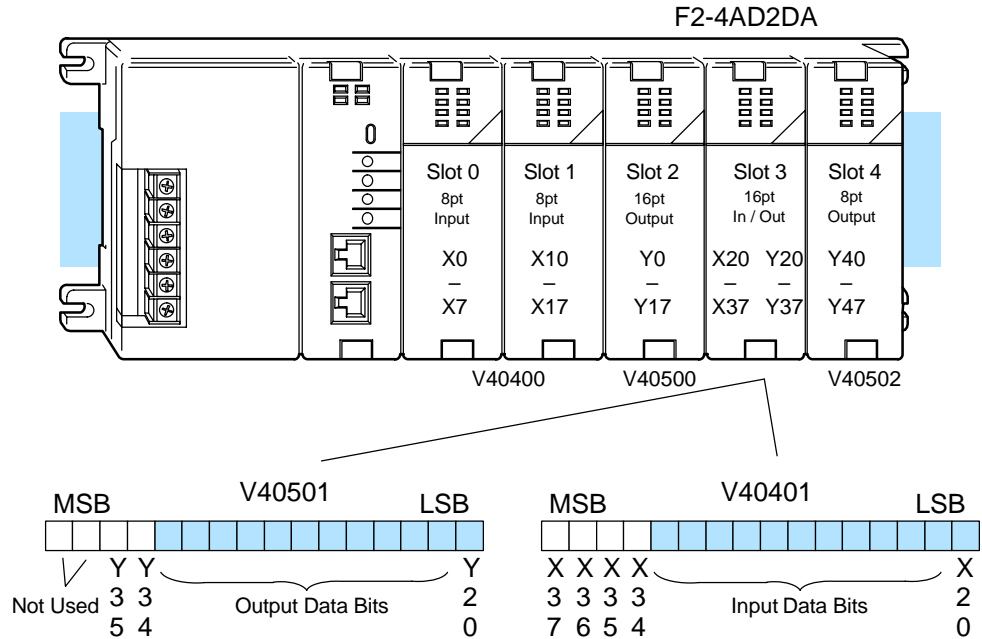

Within this word location, the individual bits represent specific information about the analog signal.

### Input Data Bits

The first twelve bits of the input word represent the analog data in binary format.

Bit	Value	Bit	Value
0	1	6	64
1	2	7	128
2	4	8	256
3	8	9	512
4	16	10	1024
5	32	11	2048

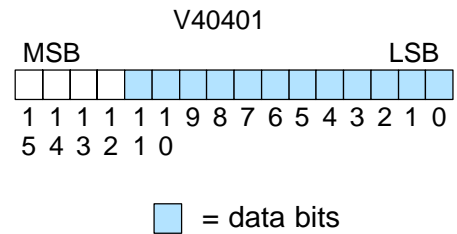

F2-4AD2DA  
4-Ch. In / 2-Ch. Out

**Active Channel Indicator Inputs**

Two of the inputs are binary encoded to indicate the active input channel. Remember, the V-memory bits are mapped directly to discrete inputs. The module automatically turns on and off these inputs to indicate the active input channel for each scan.

Scan	X35	X34	Channel
N	Off	Off	1
N+1	Off	On	2
N+2	On	Off	3
N+3	On	On	4
N+4	Off	Off	1

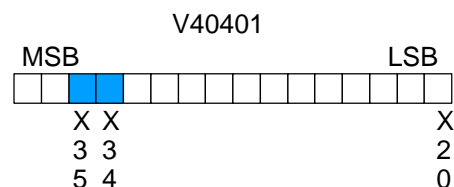

■ = channel inputs

**Diagnostic Indicator Inputs**

The last two inputs are used for module diagnostics.

*Module Busy* — The first diagnostic input (X36 in this example) indicates a “busy” condition. This input will always be active on the first PLC scan to tell the CPU the analog data is not valid. After the first scan, the input usually only comes on when environmental (electrical) noise problems are present. The programming examples in the next section will show how you can use this input. The wiring guidelines presented earlier in this chapter provide steps that can help reduce noise problems.

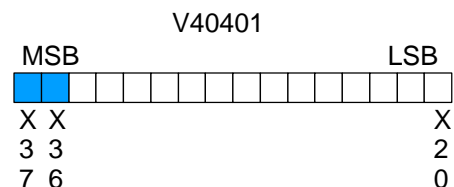

■ = diagnostic inputs

**Note:** When using the pointer method, the value placed into the V-memory location will be 8000 instead of the bit being set.

*Module Failure* — The last diagnostic input (X37 in this example) indicates that the analog module is not operating. For example, if the 24 VDC input power is missing, or if the terminal block is loose, then the module will turn on this input point. The module will also return a data value of zero to further indicate there is a problem. This input point cannot detect which individual channel is at fault. If the cause of the failure goes away, the module turns this bit off.

**Output Data Bits**

The first twelve bits of the output word represent the analog data in binary format.

Bit	Value	Bit	Value
0	1	6	64
1	2	7	128
2	4	8	256
3	8	9	512
4	16	10	1024
5	32	11	2048

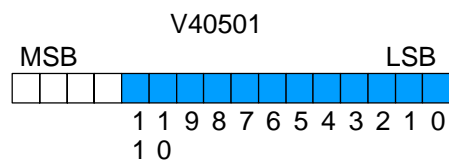

■ = data bits

F2-4AD2DA  
4-Ch. In / 2-Ch. Out

### Output Channel Selection Bits

Two of the outputs select the active channel. Remember, the V-memory bits are mapped directly to discrete outputs. Turning a bit OFF selects its channel. By controlling these outputs, you can select which channel(s) gets updated.

Y35	Y34	Channel
On	Off	1
Off	On	2
Off	Off	1 & 2 (same data to both channels)
On	On	None (both channels hold current values)

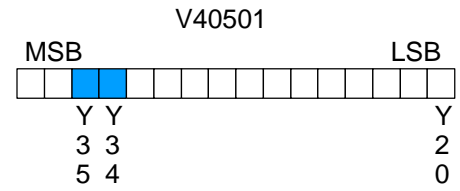

■ = channel control outputs

### Module Resolution

Since the module has 12-bit resolution, the analog signal is converted into 4096 counts ranging from 0 – 4095 ( $2^{12}$ ). For example, a 4mA signal would be 0, and a 20mA signal would be 4095. This is equivalent to a binary value of 0000 0000 0000 to 1111 1111 1111, or 000 to FFF hexadecimal. The diagram shows how this relates to the signal range.

Each count can also be expressed in terms of the signal level by using the equation shown.

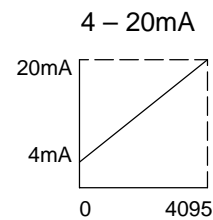

$$\text{Resolution} = \frac{H - L}{4095}$$

H = high limit of the signal range

L = low limit of the signal range

$$16\text{mA} / 4095 = 3.907\text{mA per count}$$

## Writing the Control Program

Before you begin writing the program, there are a few supplemental examples that can be extremely beneficial. They include:

- Input power failure detection
- Output data calculation
- Input data scaling

### Analog Input Power Failure Detection

Take a close look at these examples. They may be helpful for your application. The analog module has a microcontroller that can diagnose analog input circuit problems. You can easily create a simple ladder rung to detect these problems. This rung shows an input point that would be assigned if the module was used as shown in the previous and following examples.

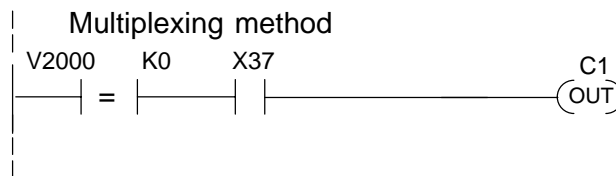

V-memory location V2000 holds channel 1 data. When a data value of zero is returned and input X37 is on, then the analog channel is not operating properly.

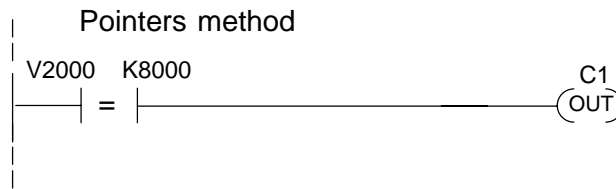

V-memory location V2000 holds channel 1 data. When a data value of 8000 is returned, then the analog channel is not operating properly.

### Calculating the Output Data

Your program has to calculate the digital value to send to the analog output channels. There are many ways to do this, but most applications are understood more easily if you use measurements in engineering units. This is accomplished by using the conversion formula shown.

You may have to make adjustments to the formula depending on the scale you choose for the engineering units.

$$A = U \frac{4095}{H - L}$$

- A = Analog value (0 – 4095)
- U = Engineering units
- H = high limit of the engineering unit range
- L = low limit of the engineering unit range

Consider the following example which controls pressure from 0.0 to 99.9 PSI. By using the formula, you can easily determine the digital value that should be sent to the module. The example shows the conversion required to yield 49.4 PSI. Notice the formula uses a multiplier of 10. This is because the decimal portion of 49.4 cannot be loaded, so you adjust the formula to compensate for it.

$$A = 10U \frac{4095}{10(H - L)}$$

$$A = 494 \frac{4095}{1000 - 0}$$

$$A = 2023$$

The example program below shows how you would write the program to perform the engineering unit conversion. This example will work with all CPUs and assumes that you have calculated or loaded the engineering unit values and stored them in V2300 and V2301 for channels 1 and 2 respectively. Also, we move the final values to V2004 and V2005, which are memory locations that are used in the following examples. You can use any user V locations, but they must match the locations that are specified as the source for the output data (see the next section for an example).



**NOTE:** The DL205 offers instructions that allow you to perform math operations using BCD format. It is usually easier to perform any math calculations in BCD.

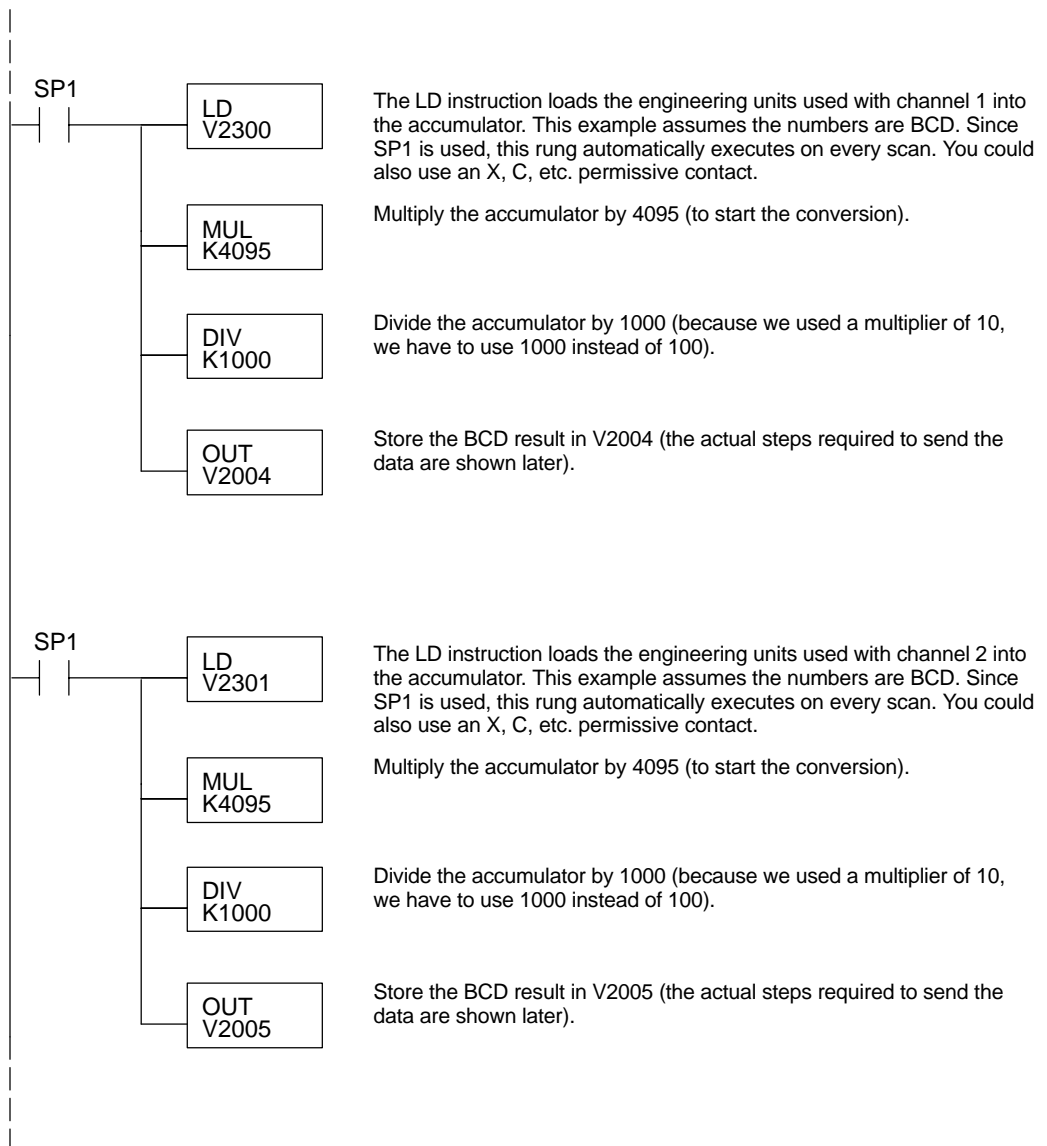

**Scaling the Input Data**

Most applications usually require measurements in engineering units, which provide more meaningful data. This is accomplished by using the conversion formula shown.

You may have to make adjustments to the formula depending on the scale you choose for the engineering units.

$$\text{Units} = A \frac{H - L}{4095}$$

H = High limit of the engineering unit range

L = Low limit of the engineering unit range

A = Analog value (0 – 4095)

For example, if you wanted to measure pressure (PSI) from 0.0 to 99.9, you would have to multiply the analog value by 10 in order to imply a decimal place when you view the value with the programming software or a handheld programmer. Notice how the calculations differ when you use the multiplier.

Analog Value of 2024, slightly less than half scale, should yield 49.4 PSI

Example without multiplier

$$\text{Units} = A \frac{H - L}{4095}$$

$$\text{Units} = 2024 \frac{100 - 0}{4095}$$

$$\text{Units} = 49$$

Handheld Display

V 2001	V 2000
0000	0049

Example with multiplier

$$\text{Units} = 10 A \frac{H - L}{4095}$$

$$\text{Units} = 20240 \frac{100 - 0}{4095}$$

$$\text{Units} = 494$$

Handheld Display

V 2001	V 2000
0000	0494

This value is more accurate

The example program below shows how you would write the program to perform the engineering unit conversion. This example assumes you have BCD data loaded into the appropriate V-memory locations using instructions that apply for the model of CPU you are using.

Note, this example uses SP1, which is always on. You could also use an X, C, etc. permissive contact.

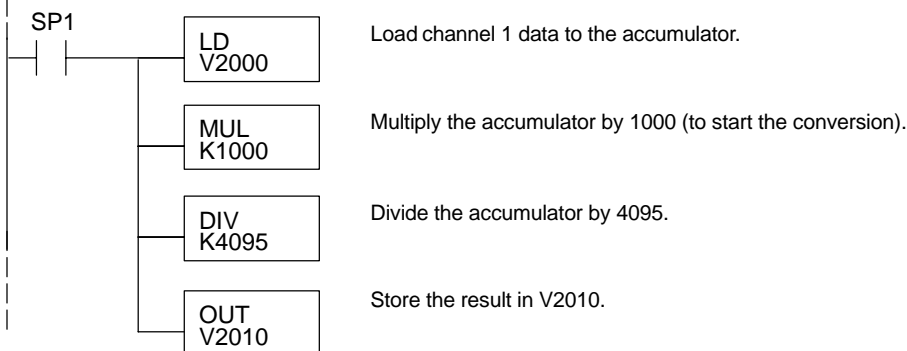

F2-4AD2DA  
4-Ch. In / 2-Ch. Out

### Read / Write Program (Pointer Method)

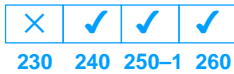

The DL240, DL250-1 and DL260 CPUs have special V-memory locations assigned to each base slot that greatly simplify the programming requirements. These V-memory locations:

- specify the number of input and output channels to scan.
- specify the storage location for the input data.
- specify the source location for the output data.

**NOTE:** To use the pointer method, DL250 CPUs must have firmware revision 1.09 or later, and F2-AD2DA modules must be revision C1 or later.

The example program shows how to setup these locations. Place this rung anywhere in the ladder program, or in the initial stage if you are using stage programming instructions. This is all that is required to read the input data into V-memory locations. The CPU automatically converts the binary input data to BCD format. Once the input data is in V-memory, you can perform math on the data, compare the data against preset values, and so forth. For the output data, you have to calculate the digital value in BCD (as shown previously) before you send the data to the module, unless you select the binary data format option shown below.

V2000 and V2004 are used as the beginning of the data areas in the example, but you can use any user V-memory locations. Also, in the previous examples the module was installed in slot 3. You should use the V-memory locations for your application. The pointer method automatically converts values to BCD.

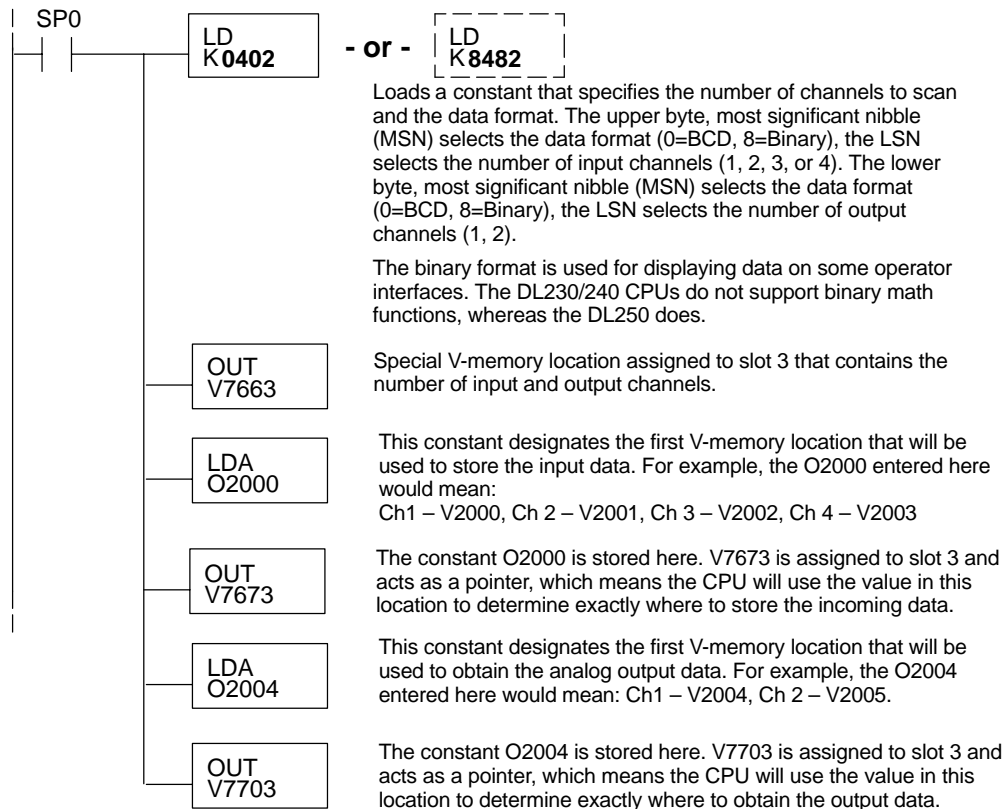

F2-4AD2DA  
4-Ch. In / 2-Ch. Out

The tables below show the special V-memory locations used by the DL240, DL250–1 and DL260 for the CPU base and local expansion base I/O slots. Slot 0 (zero) is the module next to the CPU or D2–CM module. Slot 1 is the module two places from the CPU or D2–CM, and so on. Remember, the CPU only examines the pointer values at these locations after a mode transition. Also, if you use the DL230 (multiplexing) method, verify that these addresses in the CPU are zero.

The Table below applies to the DL240, DL250–1 and DL260 CPU base.

<b>CPU Base: Analog In/Out Module Slot-Dependent V-memory Locations</b>								
Slot	0	1	2	3	4	5	6	7
No. of Channels	V7660	V7661	V7662	V7663	V7664	V7665	V7666	V7667
Input Pointer	V7670	V7671	V7672	V7673	V7674	V7675	V7676	V7677
Output Pointer	V7700	V7701	V7702	V7703	V7704	V7705	V7706	V7707

The Table below applies to the DL250–1 or DL260 expansion base 1.

<b>Expansion Base D2–CM #1: Analog In/Out Module Slot-Dependent V-memory Locations</b>								
Slot	0	1	2	3	4	5	6	7
No. of Channels	V36000	V36001	V36002	V36003	V36004	V36005	V36006	V36007
Input Pointer	V36010	V36011	V36012	V36013	V36014	V36015	V36016	V36017
Output Pointer	V36020	V36021	V36022	V36023	V36024	V36025	V36026	V36027

The Table below applies to the DL250–1 or DL260 expansion base 2.

<b>Expansion Base D2–CM #2: Analog In/Out Module Slot-Dependent V-memory Locations</b>								
Slot	0	1	2	3	4	5	6	7
No. of Channels	V36100	V36101	V36102	V36103	V36104	V36105	V36106	V36107
Input Pointer	V36110	V36111	V36112	V36113	V36114	V36115	V36116	V36117
Output Pointer	V36120	V36121	V36122	V36123	V36124	V36125	V36126	V36127

The Table below applies to the DL260 CPU expansion base 3.

<b>Expansion Base D2–CM #3: Analog In/Out Module Slot-Dependent V-memory Locations</b>								
Slot	0	1	2	3	4	5	6	7
No. of Channels	V36200	V36201	V36202	V36203	V36204	V36205	V36206	V36207
Input Pointer	V36210	V36211	V36212	V36213	V36214	V36215	V36216	V36217
Output Pointer	V36220	V36221	V36222	V36223	V36224	V36225	V36226	V36227

The Table below applies to the DL260 CPU expansion base 4.

<b>Expansion Base D2–CM #4: Analog In/Out Module Slot-Dependent V-memory Locations</b>								
Slot	0	1	2	3	4	5	6	7
No. of Channels	V36300	V36301	V36302	V36303	V36304	V36305	V36306	V36307
Input Pointer	V36310	V36311	V36312	V36313	V36314	V36315	V36316	V36317
Output Pointer	V36320	V36321	V36322	V36323	V36324	V36325	V36326	V36327

### Reading Input Values (Multiplexing)



The DL230 CPU *does not* have the special V-memory locations that allow you to automatically enable the data transfer. Since all channels are multiplexed into a single data word, the control program must be setup to determine which channel is being read. Since the module appears as X input points to the CPU, it is very easy to use the active channel status bits to determine which channel is being monitored.

Note, this example is for a module installed as shown in the previous examples. The addresses used would be different if the module was installed in another I/O arrangement. You can place these rungs anywhere in the program or if you are using stage programming, place them in a stage that is always active.

#### Load data when module is not busy.

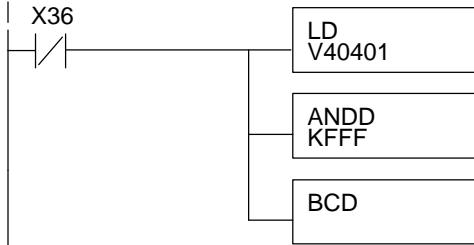

Loads the complete data word into the accumulator. The V-memory location depends on the I/O configuration. See Appendix A for the memory map.

This instruction masks the channel identification bits. Without this, the values used will not be correct so do not forget to include it.

It is usually easier to perform math operations in BCD, You can leave out this instruction if your application does not require it.

#### Store Channel 1

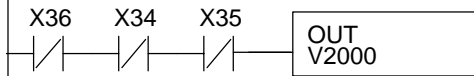

When the module is not busy and X36, X34 and X35 are off, channel 1 data is stored in V2000.

#### Store Channel 2

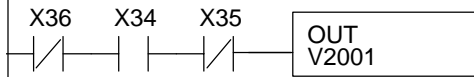

When the module is not busy and X34 is on and X35 and X36 are off, channel 2 data is stored in V2001.

#### Store Channel 3

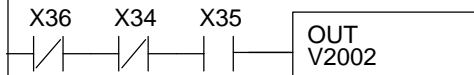

When the module is not busy and X34 and X36 are off and X35 is on, channel 3 data is stored in V2002.

#### Store Channel 4

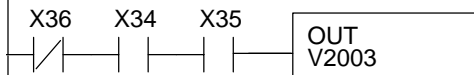

When the module is not busy and both X34 and X35 are on and X36 is off, channel 4 data is stored in V2003.

**Single Input Channel Selected (Multiplexing)**

Since you do not have to determine which channel is selected, the single channel program is even simpler.

**Store channel 1 when module is not busy.**

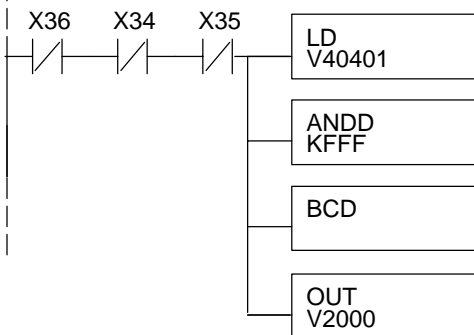

Loads the complete data word into the accumulator. The V-memory location depends on the I/O configuration. See Appendix A for the memory map.

This instruction masks the channel identification bits. Without this, the values used will not be correct so do not forget to include it.

It is usually easier to perform math operations in BCD. You can leave out this instruction if your application does not require it.

When the module is not busy and X34 and X35 are off, channel 1 data is stored in V2000.

**Writing Output Values (Multiplexing)**

The DL230 CPU *does not* have the special V-memory locations that allow you to automatically enable the data transfer. Since all channels are multiplexed into a single data word, the control program must be setup to determine which channel to write. Since the module appears as Y output points to the CPU, it is very easy to use the channel selection outputs to determine which channel to update.

Note, this example is for a module installed as shown in the previous examples. The addresses used would be different if the module was used in a different I/O arrangement. You can place these rungs anywhere in the program or if you are using stage programming, place them in a stage that is always active.

This example is a two-channel multiplexer that updates each channel on alternate scans. SP7 is a special relay that is on for one scan, then off for one scan.



**NOTE:** You must send binary data to the module. If the data is already in binary format, you should *not* use the BIN instruction shown in this example.

**Load data into the accumulator.**

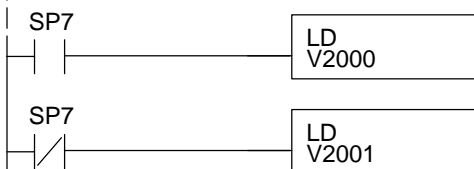

Loads the data for channel 1 into the accumulator.

Loads the data for channel 2 into the accumulator.

**Send data to V-memory assigned to the module.**

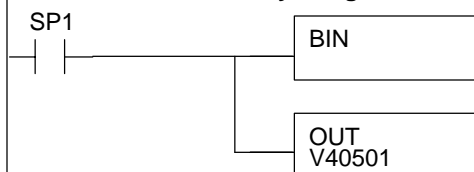

Convert the data to binary (you must omit this step if you have converted the data elsewhere). SP1 is always on.

The OUT instruction sends the data to the module. Our example starts with V40501, but the actual value depends on the location of the module in your application.

**Select the channel to update.**

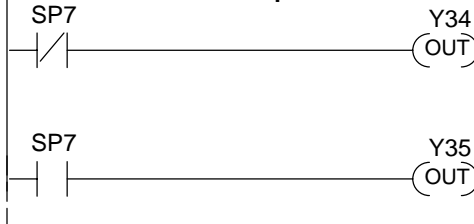

Selects channel 1 for update when Y34 is OFF (Y35-ON deselects channel 2). Note, Y34 and Y35 are used due to the previous examples. If the module was installed in a different I/O arrangement, the addresses would be different.

Selects channel 2 for update when Y35 is OFF (Y34-ON deselects channel 1). Note, Y34 and Y35 are used due to the previous examples. If the module was installed in a different I/O arrangement, addresses would be different.

F2-4AD2DA  
4-Ch. In / 2-Ch. Out

### Sending Data to One Channel (Multiplexing)

If you are not using both channels, or if you want to control the updates separately, use the following program.

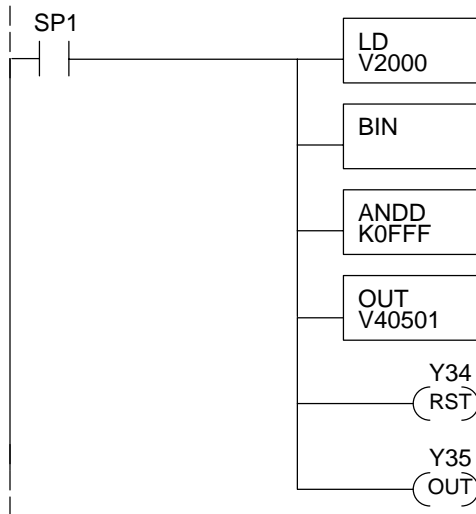

The LD instruction loads the data into the accumulator. Since SP1 is used, this rung automatically executes on every scan. You could also use an X, C, etc. permissive contact.

The BIN instruction converts the accumulator data to binary (you must omit this step if you have already converted the data elsewhere).

The ANDD instruction masks off the channel select bits to prevent an accidental channel selection.

The OUT instruction sends the data to the module. Our example starts with V40501, but the actual value depends on the location of the module in your application.

Y34-OFF selects channel 1 for updating.

Y35-ON deselected channel 2 (do not update).

### Sending the Same Data to Both Channels (Multiplexing)

If both channel selection outputs are off, both channels will be updated with the same data.

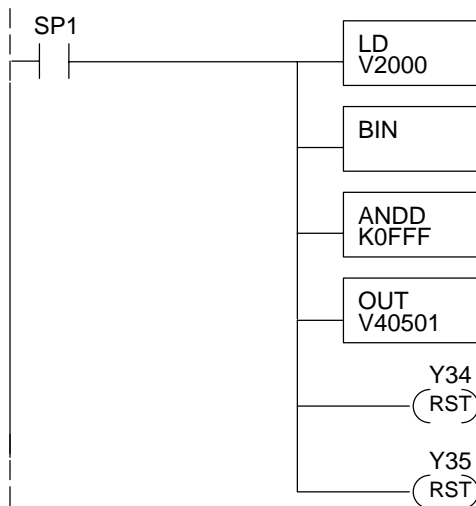

The LD instruction loads the data into the accumulator. Since SP1 is used, this rung automatically executes on every scan. You could also use an X, C, etc. permissive contact.

The BIN instruction converts the accumulator data to binary (you must omit this step if you have already converted the data elsewhere).

The ANDD instruction masks off the channel select bits to prevent an accidental channel selection.

The OUT instruction sends the data to the module. Our example starts with V40501, but the actual value depends on the location of the module in your application.

Y34-OFF selects channel 1 for updating.

Y35-OFF selects channel 2 for updating.

### Analog and Digital Value Conversions

Sometimes it is useful to be able to quickly convert between the signal levels and the digital values. This is especially helpful during machine startup or troubleshooting. The table provides formulas to make this conversion easier.

Range	If you know the digital value ...	If you know the analog signal level ...
4 to 20mA	$A = \frac{16D}{4095} + 4$	$D = \frac{4095}{16}(A - 4)$

For example, if you have measured the signal at 10mA, you could use the formula to easily determine the digital value (D) that should be stored in the V-memory location that contains the data.

$$D = \frac{4095}{16}(A - 4)$$

$$D = \frac{4095}{16}(10\text{mA} - 4)$$

$$D = (255.93) (6)$$

$$D = 1536$$

**Filtering Input Noise (DL250-1, DL260 CPUs Only)**

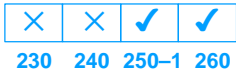

Add the following logic to filter and smooth analog input noise in DL250-1 or DL260 CPUs. This is especially useful when using PID loops. Noise can be generated by the field device and/or induced by field wiring.

The analog value in BCD is first converted to a binary number because there is not a BCD-to-real conversion instruction. Memory location V1400 is the designated workspace in this example. The MULR instruction is the filter factor, which can be from 0.1 to 0.9. The example uses 0.2. A smaller filter factor increases filtering. You can use a higher precision value, but it is not generally needed. The filtered value is then converted back to binary and then to BCD. The filtered value is stored in location V1402 for use in your application or PID loop.

**NOTE:** Be careful not to do a multiple number conversion on a value. For example, if you are using the pointer method to get the analog value, it is in BCD and must be converted to binary. However, if you are using the conventional method of reading analog and are masking the first twelve bits, then it is already in binary and no conversion using the BIN instruction is needed.

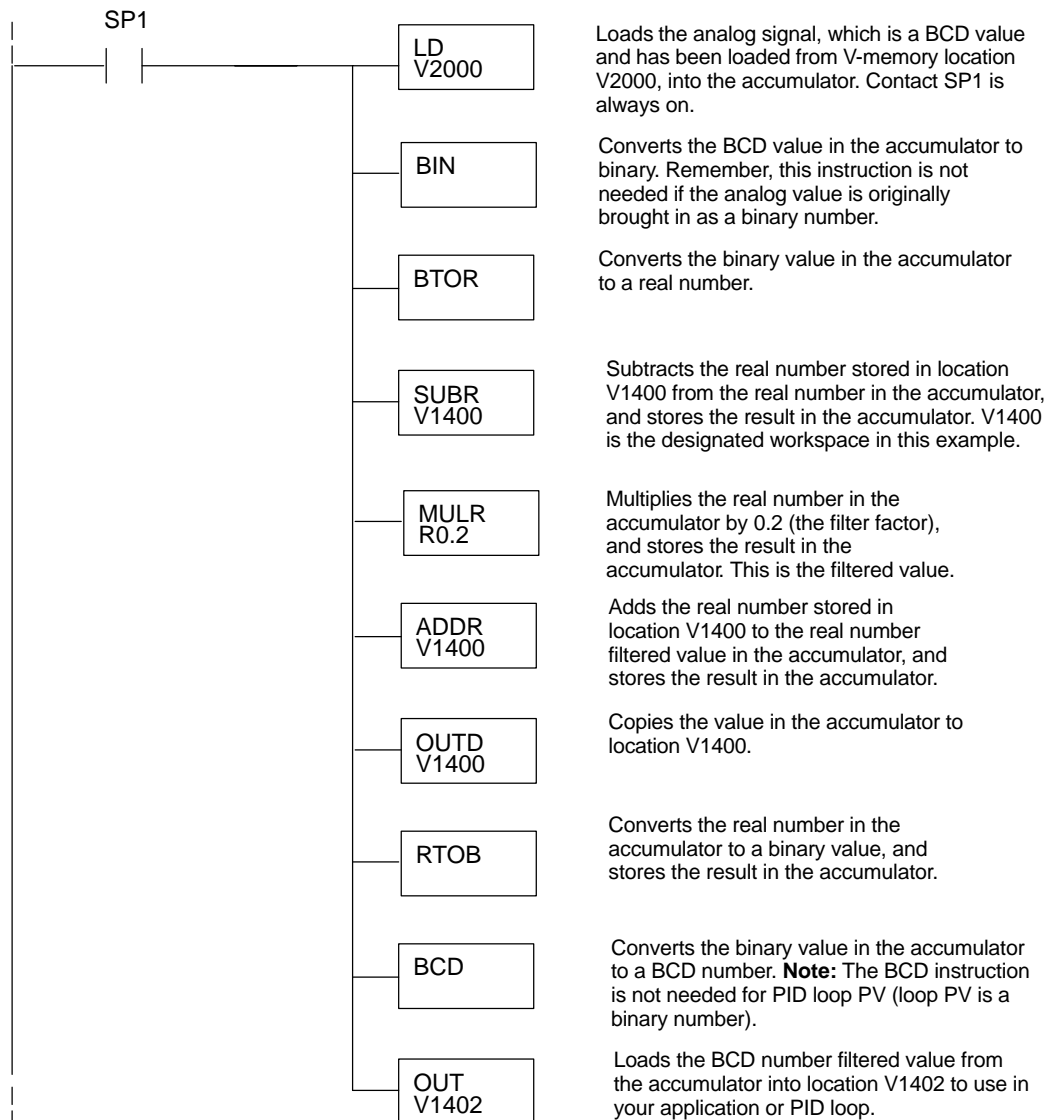

F2-4AD2DA  
4-Ch. In / 2-Ch. Out

# DL205 Discrete I/O Memory Map

---

In This Chapter. . . .

- X Input / Y Output Bit Map
  - Control Relay Bit Map
  - Global I/O (GX, GY) Bit Map
-

## X Input / Y Output Bit Map

This table provides a listing of the individual Input points associated with each V-memory address bit for the DL230, DL240, and DL250-1 and DL260 CPUs. The DL250-1 ranges apply to the DL250.

DL230 / DL240 / DL250-1 / DL260 Input (X) and Output (Y) Points																X Input Address	Y Output Address
MSB															LSB		
17	16	15	14	13	12	11	10	7	6	5	4	3	2	1	0		
017	016	015	014	013	012	011	010	007	006	005	004	003	002	001	000	V40400	V40500
037	036	035	034	033	032	031	030	027	026	025	024	023	022	021	020	V40401	V40501
057	056	055	054	053	052	051	050	047	046	045	044	043	042	041	040	V40402	V40502
077	076	075	074	073	072	071	070	067	066	065	064	063	062	061	060	V40403	V40503
117	116	115	114	113	112	111	110	107	106	105	104	103	102	101	100	V40404	V40504
137	136	135	134	133	132	131	130	127	126	125	124	123	122	121	120	V40405	V40505
157	156	155	154	153	152	151	150	147	146	145	144	143	142	141	140	V40406	V40506
177	176	175	174	173	172	171	170	167	166	165	164	163	162	161	160	V40407	V40507
DL240 / DL250-1 / DL260 Input (X) and Output (Y) Points																	
MSB															LSB		
217	216	215	214	213	212	211	210	207	206	205	204	203	202	201	200	V40410	V40510
237	236	235	234	233	232	231	230	227	226	225	224	223	222	221	220	V40411	V40511
257	256	255	254	253	252	251	250	247	246	245	244	243	242	241	240	V40412	V40512
277	276	275	274	273	272	271	270	267	266	265	264	263	262	261	260	V40413	V40513
317	316	315	314	313	312	311	310	307	306	305	304	303	302	301	300	V40414	V40514
337	336	335	334	333	332	331	330	327	326	325	324	323	322	321	320	V40415	V40515
357	356	355	354	353	352	351	350	347	346	345	344	343	342	341	340	V40416	V40516
377	376	375	374	373	372	371	370	367	366	365	364	363	362	361	360	V40417	V40517
417	416	415	414	413	412	411	410	407	406	405	404	403	402	401	400	V40420	V40520
437	436	435	434	433	432	431	430	427	426	425	424	423	422	421	420	V40421	V40521
457	456	455	454	453	452	451	450	447	446	445	444	443	442	441	440	V40422	V40522
477	476	475	474	473	472	471	470	467	466	465	464	463	462	461	460	V40423	V40523
DL250-1 / DL260 Additional Input (X) and Output (Y) Points																	
MSB															LSB		
517	516	515	514	513	512	511	510	507	506	505	504	503	502	501	500	V40424	V40524
537	536	535	534	533	532	531	530	527	526	525	524	523	522	521	520	V40425	V40525
557	556	555	554	553	552	551	550	547	546	545	544	543	542	541	540	V40426	V40526
577	576	575	574	573	572	571	570	567	566	565	564	563	562	561	560	V40427	V40527
617	616	615	614	613	612	611	610	607	606	605	604	603	602	601	600	V40430	V40530
637	636	635	634	633	632	631	630	627	626	625	624	623	622	621	620	V40431	V40531
657	656	655	654	653	652	651	650	647	646	645	644	643	642	641	640	V40432	V40532
677	676	675	674	673	672	671	670	667	666	665	664	663	662	661	660	V40433	V40533
717	716	715	714	713	712	711	710	707	706	705	704	703	702	701	700	V40434	V40534
737	736	735	734	733	732	731	730	727	726	725	724	723	722	721	720	V40435	V40535
757	756	755	754	753	752	751	750	747	746	745	744	743	742	741	740	V40436	V40536
777	776	775	774	773	772	771	770	767	766	765	764	763	762	761	760	V40437	V40537

DL260 Additional Input (X) and Output (Y) Points (cont'd)															X Input Address	Y Output Address	
MSB														LSB			
17	16	15	14	13	12	11	10	7	6	5	4	3	2	1	0		
1017	1016	1015	1014	1013	1012	1011	1010	1007	1006	1005	1004	1003	1002	1001	1000	V40440	V40540
1037	1036	1035	1034	1033	1032	1031	1030	1027	1026	1025	1024	1023	1022	1021	1020	V40441	V40541
1057	1056	1055	1054	1053	1052	1051	1050	1047	1046	1045	1044	1043	1042	1041	1040	V40442	V40542
1077	1076	1075	1074	1073	1072	1071	1070	1067	1066	1065	1064	1063	1062	1061	1060	V40443	V40543
1117	1116	1115	1114	1113	1112	1111	1110	1107	1106	1105	1104	1103	1102	1101	1100	V40444	V40544
1137	1136	1135	1134	1133	1132	1131	1130	1127	1126	1125	1124	1123	1122	1121	1120	V40445	V40545
1157	1156	1155	1154	1153	1152	1151	1150	1147	1146	1145	1144	1143	1142	1141	1140	V40446	V40546
1177	1176	1175	1174	1173	1172	1171	1170	1167	1166	1165	1164	1163	1162	1161	1160	V40447	V40547
1217	1216	1215	1214	1213	1212	1211	1210	1207	1206	1205	1204	1203	1202	1201	1200	V40450	V40550
1237	1236	1235	1234	1233	1232	1231	1230	1227	1226	1225	1224	1223	1222	1221	1220	V40451	V40551
1257	1256	1255	1254	1253	1252	1251	1250	1247	1246	1245	1244	1243	1242	1241	1240	V40452	V40552
1277	1276	1275	1274	1273	1272	1271	1270	1267	1266	1265	1264	1263	1262	1261	1260	V40453	V40553
1317	1316	1315	1314	1313	1312	1311	1310	1307	1306	1305	1304	1303	1302	1301	1300	V40454	V40554
1337	1336	1335	1334	1333	1332	1331	1330	1327	1326	1325	1324	1323	1322	1321	1320	V40455	V40555
1357	1356	1355	1354	1353	1352	1351	1350	1347	1346	1345	1344	1343	1342	1341	1340	V40456	V40556
1377	1376	1375	1374	1373	1372	1371	1370	1367	1366	1365	1364	1363	1362	1361	1360	V40457	V40557
1417	1416	1415	1414	1413	1412	1411	1410	1407	1406	1405	1404	1403	1402	1401	1400	V40460	V40560
1437	1436	1435	1434	1433	1432	1431	1430	1427	1426	1425	1424	1423	1422	1421	1420	V40461	V40561
1457	1456	1455	1454	1453	1452	1451	1450	1447	1446	1445	1444	1443	1442	1441	1440	V40462	V40562
1477	1476	1475	1474	1473	1472	1471	1470	1467	1466	1465	1464	1463	1462	1461	1460	V40463	V40563
1517	1516	1515	1514	1513	1512	1511	1510	1507	1506	1505	1504	1503	1502	1501	1500	V40464	V40564
1537	1536	1535	1534	1533	1532	1531	1530	1527	1526	1525	1524	1523	1522	1521	1520	V40465	V40565
1557	1556	1555	1554	1553	1552	1551	1550	1547	1546	1545	1544	1543	1542	1541	1540	V40466	V40566
1577	1576	1575	1574	1573	1572	1571	1570	1567	1566	1565	1564	1563	1562	1561	1560	V40467	V40567
1617	1616	1615	1614	1613	1612	1611	1610	1607	1606	1605	1604	1603	1602	1601	1600	V40470	V40570
1637	1636	1635	1634	1633	1632	1631	1630	1627	1626	1625	1624	1623	1622	1621	1620	V40471	V40571
1657	1656	1655	1654	1653	1652	1651	1650	1647	1646	1645	1644	1643	1642	1641	1640	V40472	V40572
1677	1676	1675	1674	1673	1672	1671	1670	1667	1666	1665	1664	1663	1662	1661	1660	V40473	V40573
1717	1716	1715	1714	1713	1712	1711	1710	1707	1706	1705	1704	1703	1702	1701	1700	V40474	V40574
1737	1736	1735	1734	1733	1732	1731	1730	1727	1726	1725	1724	1723	1722	1721	1720	V40475	V40575
1757	1756	1755	1754	1753	1752	1751	1750	1747	1746	1745	1744	1743	1742	1741	1740	V40476	V40576
1777	1776	1775	1774	1773	1772	1771	1770	1767	1766	1765	1764	1763	1762	1761	1760	V40477	V40577

## Control Relay Bit Map

This table provides a listing of the individual control relays associated with each V-memory address bit.

DL230 / DL240 / DL250 -1 / DL260 Control Relays (C)															Address	
MSB																LSB
17	16	15	14	13	12	11	10	7	6	5	4	3	2	1	0	
017	016	015	014	013	012	011	010	007	006	005	004	003	002	001	000	V40600
037	036	035	034	033	032	031	030	027	026	025	024	023	022	021	020	V40601
057	056	055	054	053	052	051	050	047	046	045	044	043	042	041	040	V40602
077	076	075	074	073	072	071	070	067	066	065	064	063	062	061	060	V40603
117	116	115	114	113	112	111	110	107	106	105	104	103	102	101	100	V40604
137	136	135	134	133	132	131	130	127	126	125	124	123	122	121	120	V40605
157	156	155	154	153	152	151	150	147	146	145	144	143	142	141	140	V40606
177	176	175	174	173	172	171	170	167	166	165	164	163	162	161	160	V40607
217	216	215	214	213	212	211	210	207	206	205	204	203	202	201	200	V40610
237	236	235	234	233	232	231	230	227	226	225	224	223	222	221	220	V40611
257	256	255	254	253	252	251	250	247	246	245	244	243	242	241	240	V40612
277	276	275	274	273	272	271	270	267	266	265	264	263	262	261	260	V40613
317	316	315	314	313	312	311	310	307	306	305	304	303	302	301	300	V40614
337	336	335	334	333	332	331	330	327	326	325	324	323	322	321	320	V40615
357	356	355	354	353	352	351	350	347	346	345	344	343	342	341	340	V40616
377	376	375	374	373	372	371	370	367	366	365	364	363	362	361	360	V40617

Additional DL250-1 / DL260 Control Relays (C)															Address	
MSB																LSB
417	416	415	414	413	412	411	410	407	406	405	404	403	402	401	400	V40620
437	436	435	434	433	432	431	430	427	426	425	424	423	422	421	420	V40621
457	456	455	454	453	452	451	450	447	446	445	444	443	442	441	440	V40622
477	476	475	474	473	472	471	470	467	466	465	464	463	462	461	460	V40623
517	516	515	514	513	512	511	510	507	506	505	504	503	502	501	500	V40624
537	536	535	534	533	532	531	530	527	526	525	524	523	522	521	520	V40625
557	556	555	554	553	552	551	550	547	546	545	544	543	542	541	540	V40626
577	576	575	574	573	572	571	570	567	566	565	564	563	562	561	560	V40627
617	616	615	614	613	612	611	610	607	606	605	604	603	602	601	600	V40630
637	636	635	634	633	632	631	630	627	626	625	624	623	622	621	620	V40631
657	656	655	654	653	652	651	650	647	646	645	644	643	642	641	640	V40632
677	676	675	674	673	672	671	670	667	666	665	664	663	662	661	660	V40633
717	716	715	714	713	712	711	710	707	706	705	704	703	702	701	700	V40634
737	736	735	734	733	732	731	730	727	726	725	724	723	722	721	720	V40635
757	756	755	754	753	752	751	750	747	746	745	744	743	742	741	740	V40636
777	776	775	774	773	772	771	770	767	766	765	764	763	762	761	760	V40637

Additional DL250-1 / DL260 Control Relays (C)															Address		
MSB	17	16	15	14	13	12	11	10	7	6	5	4	3	2		1	0
1017	1016	1015	1014	1013	1012	1011	1010	1007	1006	1005	1004	1003	1002	1001	1000	V40640	
1037	1036	1035	1034	1033	1032	1031	1030	1027	1026	1025	1024	1023	1022	1021	1020	V40641	
1057	1056	1055	1054	1053	1052	1051	1050	1047	1046	1045	1044	1043	1042	1041	1040	V40642	
1077	1076	1075	1074	1073	1072	1071	1070	1067	1066	1065	1064	1063	1062	1061	1060	V40643	
1117	1116	1115	1114	1113	1112	1111	1110	1107	1106	1105	1104	1103	1102	1101	1100	V40644	
1137	1136	1135	1134	1133	1132	1131	1130	1127	1126	1125	1124	1123	1122	1121	1120	V40645	
1157	1156	1155	1154	1153	1152	1151	1150	1147	1146	1145	1144	1143	1142	1141	1140	V40646	
1177	1176	1175	1174	1173	1172	1171	1170	1167	1166	1165	1164	1163	1162	1161	1160	V40647	
1217	1216	1215	1214	1213	1212	1211	1210	1207	1206	1205	1204	1203	1202	1201	1200	V40650	
1237	1236	1235	1234	1233	1232	1231	1230	1227	1226	1225	1224	1223	1222	1221	1220	V40651	
1257	1256	1255	1254	1253	1252	1251	1250	1247	1246	1245	1244	1243	1242	1241	1240	V40652	
1277	1276	1275	1274	1273	1272	1271	1270	1267	1266	1265	1264	1263	1262	1261	1260	V40653	
1317	1316	1315	1314	1313	1312	1311	1310	1307	1306	1305	1304	1303	1302	1301	1300	V40654	
1337	1336	1335	1334	1333	1332	1331	1330	1327	1326	1325	1324	1323	1322	1321	1320	V40655	
1357	1356	1355	1354	1353	1352	1351	1350	1347	1346	1345	1344	1343	1342	1341	1340	V40656	
1377	1376	1375	1374	1373	1372	1371	1370	1367	1366	1365	1364	1363	1362	1361	1360	V40657	
1417	1416	1415	1414	1413	1412	1411	1410	1407	1406	1405	1404	1403	1402	1401	1400	V40660	
1437	1436	1435	1434	1433	1432	1431	1430	1427	1426	1425	1424	1423	1422	1421	1420	V40661	
1457	1456	1455	1454	1453	1452	1451	1450	1447	1446	1445	1444	1443	1442	1441	1440	V40662	
1477	1476	1475	1474	1473	1472	1471	1470	1467	1466	1465	1464	1463	1462	1461	1460	V40663	
1517	1516	1515	1514	1513	1512	1511	1510	1507	1506	1505	1504	1503	1502	1501	1500	V40664	
1537	1536	1535	1534	1533	1532	1531	1530	1527	1526	1525	1524	1523	1522	1521	1520	V40665	
1557	1556	1555	1554	1553	1552	1551	1550	1547	1546	1545	1544	1543	1542	1541	1540	V40666	
1577	1576	1575	1574	1573	1572	1571	1570	1567	1566	1565	1564	1563	1562	1561	1560	V40667	
1617	1616	1615	1614	1613	1612	1611	1610	1607	1606	1605	1604	1603	1602	1601	1600	V40670	
1637	1636	1635	1634	1633	1632	1631	1630	1627	1626	1625	1624	1623	1622	1621	1620	V40671	
1657	1656	1655	1654	1653	1652	1651	1650	1647	1646	1645	1644	1643	1642	1641	1640	V40672	
1677	1676	1675	1674	1673	1672	1671	1670	1667	1666	1665	1664	1663	1662	1661	1660	V40673	
1717	1716	1715	1714	1713	1712	1711	1710	1707	1706	1705	1704	1703	1702	1701	1700	V40674	
1737	1736	1735	1734	1733	1732	1731	1730	1727	1726	1725	1724	1723	1722	1721	1720	V40675	
1757	1756	1755	1754	1753	1752	1751	1750	1747	1746	1745	1744	1743	1742	1741	1740	V40676	
1777	1776	1775	1774	1773	1772	1771	1770	1767	1766	1765	1764	1763	1762	1761	1760	V40677	

This portion of the table shows additional Control Relays points available with the DL260.

DL260 Additional Control Relays (C)															Address	
MSB																LSB
17	16	15	14	13	12	11	10	7	6	5	4	3	2	1	0	
2017	2016	2015	2014	2013	2012	2011	2010	2007	2006	2005	2004	2003	2002	2001	2000	V40700
2037	2036	2035	2034	2033	2032	2031	2030	2027	2026	2025	2024	2023	2022	2021	2020	V40701
2057	2056	2055	2054	2053	2052	2051	2050	2047	2046	2045	2044	2043	2042	2041	2040	V40702
2077	2076	2075	2074	2073	2072	2071	2070	2067	2066	2065	2064	2063	2062	2061	2060	V40703
2117	2116	2115	2114	2113	2112	2111	2110	2107	2106	2105	2104	2103	2102	2101	2100	V40704
2137	2136	2135	2134	2133	2132	2131	2130	2127	2126	2125	2124	2123	2122	2121	2120	V40705
2157	2156	2155	2154	2153	2152	2151	2150	2147	2146	2145	2144	2143	2142	2141	2140	V40706
2177	2176	2175	2174	2173	2172	2171	2170	2167	2166	2165	2164	2163	2162	2161	2160	V40707
2217	2216	2215	2214	2213	2212	2211	2210	2207	2206	2205	2204	2203	2202	2201	2200	V40710
2237	2236	2235	2234	2233	2232	2231	2230	2227	2226	2225	2224	2223	2222	2221	2220	V40711
2257	2256	2255	2254	2253	2252	2251	2250	2247	2246	2245	2244	2243	2242	2241	2240	V40712
2277	2276	2275	2274	2273	2272	2271	2270	2267	2266	2265	2264	2263	2262	2261	2260	V40713
2317	2316	2315	2314	2313	2312	2311	2310	2307	2306	2305	2304	2303	2302	2301	2300	V40714
2337	2336	2335	2334	2333	2332	2331	2330	2327	2326	2325	2324	2323	2322	2321	2320	V40715
2357	2356	2355	2354	2353	2352	2351	2350	2347	2346	2345	2344	2343	2342	2341	2340	V40716
2377	2376	2375	2374	2373	2372	2371	2370	2367	2366	2365	2364	2363	2362	2361	2360	V40717
2417	2416	2415	2414	2413	2412	2411	2410	2407	2406	2405	2404	2403	2402	2401	2400	V40720
2437	2436	2435	2434	2433	2432	2431	2430	2427	2426	2425	2424	2423	2422	2421	2420	V40721
2457	2456	2455	2454	2453	2452	2451	2450	2447	2446	2445	2444	2443	2442	2441	2440	V40722
2477	2476	2475	2474	2473	2472	2471	2470	2467	2466	2465	2464	2463	2462	2461	2460	V40723
2517	2516	2515	2514	2513	2512	2511	2510	2507	2506	2505	2504	2503	2502	2501	2500	V40724
2537	2536	2535	2534	2533	2532	2531	2530	2527	2526	2525	2524	2523	2522	2521	2520	V40725
2557	2556	2555	2554	2553	2552	2551	2550	2547	2546	2545	2544	2543	2542	2541	2540	V40726
2577	2576	2575	2574	2573	2572	2571	2570	2567	2566	2565	2564	2563	2562	2561	2560	V40727
2617	2616	2615	2614	2613	2612	2611	2610	2607	2606	2605	2604	2603	2602	2601	2600	V40730
2637	2636	2635	2634	2633	2632	2631	2630	2627	2626	2625	2624	2623	2622	2621	2620	V40731
2657	2656	2655	2654	2653	2652	2651	2650	2647	2646	2645	2644	2643	2642	2641	2640	V40732
2677	2676	2675	2674	2673	2672	2671	2670	2667	2666	2665	2664	2663	2662	2661	2660	V40733
2717	2716	2715	2714	2713	2712	2711	2710	2707	2706	2705	2704	2703	2702	2701	2700	V40734
2737	2736	2735	2734	2733	2732	2731	2730	2727	2726	2725	2724	2723	2722	2721	2720	V40735
2757	2756	2755	2754	2753	2752	2751	2750	2747	2746	2745	2744	2743	2742	2741	2740	V40736
2777	2776	2775	2774	2773	2772	2771	2770	2767	2766	2765	2764	2763	2762	2761	2760	V40737

DL260 Additional Control Relays (C) (cont'd)															MSB	LSB	Address
17	16	15	14	13	12	11	10	7	6	5	4	3	2	1	0		
3017	3016	3015	3014	3013	3012	3011	3010	3007	3006	3005	3004	3003	3002	3001	3000	V40740	
3037	3036	3035	3034	3033	3032	3031	3030	3027	3026	3025	3024	3023	3022	3021	3020	V40741	
3057	3056	3055	3054	3053	3052	3051	3050	3047	3046	3045	3044	3043	3042	3041	3040	V40742	
3077	3076	3075	3074	3073	3072	3071	3070	3067	3066	3065	3064	3063	3062	3061	3060	V40743	
3117	3116	3115	3114	3113	3112	3111	3110	3107	3106	3105	3104	3103	3102	3101	3100	V40744	
3137	3136	3135	3134	3133	3132	3131	3130	3127	3126	3125	3124	3123	3122	3121	3120	V40745	
3157	3156	3155	3154	3153	3152	3151	3150	3147	3146	3145	3144	3143	3142	3141	3140	V40746	
3177	3176	3175	3174	3173	3172	3171	3170	3167	3166	3165	3164	3163	3162	3161	3160	V40747	
3217	3216	3215	3214	3213	3212	3211	3210	3207	3206	3205	3204	3203	3202	3201	3200	V40750	
3237	3236	3235	3234	3233	3232	3231	3230	3227	3226	3225	3224	3223	3222	3221	3220	V40751	
3257	3256	3255	3254	3253	3252	3251	3250	3247	3246	3245	3244	3243	3242	3241	3240	V40752	
3277	3276	3275	3274	3273	3272	3271	3270	3267	3266	3265	3264	3263	3262	3261	3260	V40753	
3317	3316	3315	3314	3313	3312	3311	3310	3307	3306	3305	3304	3303	3302	3301	3300	V40754	
3337	3336	3335	3334	3333	3332	3331	3330	3327	3326	3325	3324	3323	3322	3321	3320	V40755	
3357	3356	3355	3354	3353	3352	3351	3350	3347	3346	3345	3344	3343	3342	3341	3340	V40756	
3377	3376	3375	3374	3373	3372	3371	3370	3367	3366	3365	3364	3363	3362	3361	3360	V40757	
3417	3416	3415	3414	3413	3412	3411	3410	3407	3406	3405	3404	3403	3402	3401	3400	V40760	
3437	3436	3435	3434	3433	3432	3431	3430	3427	3426	3425	3424	3423	3422	3421	3420	V40761	
3457	3456	3455	3454	3453	3452	3451	3450	3447	3446	3445	3444	3443	3442	3441	3440	V40762	
3477	3476	3475	3474	3473	3472	3471	3470	3467	3466	3465	3464	3463	3462	3461	3460	V40763	
3517	3516	3515	3514	3513	3512	3511	3510	3507	3506	3505	3504	3503	3502	3501	3500	V40764	
3537	3536	3535	3534	3533	3532	3531	3530	3527	3526	3525	3524	3523	3522	3521	3520	V40765	
3557	3556	3555	3554	3553	3552	3551	3550	3547	3546	3545	3544	3543	3542	3541	3540	V40766	
3577	3576	3575	3574	3573	3572	3571	3570	3567	3566	3565	3564	3563	3562	3561	3560	V40767	
3617	3616	3615	3614	3613	3612	3611	3610	3607	3606	3605	3604	3603	3602	3601	3600	V40770	
3637	3636	3635	3634	3633	3632	3631	3630	3627	3626	3625	3624	3623	3622	3621	3620	V40771	
3657	3656	3655	3654	3653	3652	3651	3650	3647	3646	3645	3644	3643	3642	3641	3640	V40772	
3677	3676	3675	3674	3673	3672	3671	3670	3667	3666	3665	3664	3663	3662	3661	3660	V40773	
3717	3716	3715	3714	3713	3712	3711	3710	3707	3706	3705	3704	3703	3702	3701	3700	V40774	
3737	3736	3735	3734	3733	3732	3731	3730	3727	3726	3725	3724	3723	3722	3721	3720	V40775	
3757	3756	3755	3754	3753	3752	3751	3750	3747	3746	3745	3744	3743	3742	3741	3740	V40776	
3777	3776	3775	3774	3773	3772	3771	3770	3767	3766	3765	3764	3763	3762	3761	3760	V40777	

## Remote I/O Bit Map (DL 260 only)

This table provides a listing of the individual remote I/O points associated with each V-memory address bit.

DL260 Remote I/O (GX) and (GY) Points															GX Address	GY Address	
MSB														LSB			
17	16	15	14	13	12	11	10	7	6	5	4	3	2	1	0		
017	016	015	014	013	012	011	010	007	006	005	004	003	002	001	000	V40000	V40200
037	036	035	034	033	032	031	030	027	026	025	024	023	022	021	020	V40001	V40201
057	056	055	054	053	052	051	050	047	046	045	044	043	042	041	040	V40002	V40202
077	076	075	074	073	072	071	070	067	066	065	064	063	062	061	060	V40003	V40203
117	116	115	114	113	112	111	110	107	106	105	104	103	102	101	100	V40004	V40204
137	136	135	134	133	132	131	130	127	126	125	124	123	122	121	120	V40005	V40205
157	156	155	154	153	152	151	150	147	146	145	144	143	142	141	140	V40006	V40206
177	176	175	174	173	172	171	170	167	166	165	164	163	162	161	160	V40007	V40207
217	216	215	214	213	212	211	210	207	206	205	204	203	202	201	200	V40010	V40210
237	236	235	234	233	232	231	230	227	226	225	224	223	222	221	220	V40011	V40211
257	256	255	254	253	252	251	250	247	246	245	244	243	242	241	240	V40012	V40212
277	276	275	274	273	272	271	270	267	266	265	264	263	262	261	260	V40013	V40213
317	316	315	314	313	312	311	310	307	306	305	304	303	302	301	300	V40014	V40214
337	336	335	334	333	332	331	330	327	326	325	324	323	322	321	320	V40015	V40215
357	356	355	354	353	352	351	350	347	346	345	344	343	342	341	340	V40016	V40216
377	376	375	374	373	372	371	370	367	366	365	364	363	362	361	360	V40017	V40217
417	416	415	414	413	412	411	410	407	406	405	404	403	402	401	400	V40020	V40220
437	436	435	434	433	432	431	430	427	426	425	424	423	422	421	420	V40021	V40221
457	456	455	454	453	452	451	450	447	446	445	444	443	442	441	440	V40022	V40222
477	476	475	474	473	472	471	470	467	466	465	464	463	462	461	460	V40023	V40223
517	516	515	514	513	512	511	510	507	506	505	504	503	502	501	500	V40024	V40224
537	536	535	534	533	532	531	530	527	526	525	524	523	522	521	520	V40025	V40225
557	556	555	554	553	552	551	550	547	546	545	544	543	542	541	540	V40026	V40226
577	576	575	574	573	572	571	570	567	566	565	564	563	562	561	560	V40027	V40227
617	616	615	614	613	612	611	610	607	606	605	604	603	602	601	600	V40030	V40230
637	636	635	634	633	632	631	630	627	626	625	624	623	622	621	620	V40031	V40231
657	656	655	654	653	652	651	650	647	646	645	644	643	642	641	640	V40032	V40232
677	676	675	674	673	672	671	670	667	666	665	664	663	662	661	660	V40033	V40233
717	716	715	714	713	712	711	710	707	706	705	704	703	702	701	700	V40034	V40234
737	736	735	734	733	732	731	730	727	726	725	724	723	722	721	720	V40035	V40235
757	756	755	754	753	752	751	750	747	746	745	744	743	742	741	740	V40036	V40236
777	776	775	774	773	772	771	770	767	766	765	764	763	762	761	760	V40037	V40237

DL260 Remote I/O (GX) and (GY) Points															GX Address	GY Address	
MSB							LSB										
17	16	15	14	13	12	11	10	7	6	5	4	3	2	1	0		
1017	1016	1015	1014	1013	1012	1011	1010	1007	1006	1005	1004	1003	1002	1001	1000	V40040	V40240
1037	1036	1035	1034	1033	1032	1031	1030	1027	1026	1025	1024	1023	1022	1021	1020	V40041	V40241
1057	1056	1055	1054	1053	1052	1051	1050	1047	1046	1045	1044	1043	1042	1041	1040	V40042	V40242
1077	1076	1075	1074	1073	1072	1071	1070	1067	1066	1065	1064	1063	1062	1061	1060	V40043	V40243
1117	1116	1115	1114	1113	1112	1111	1110	1107	1106	1105	1104	1103	1102	1101	1100	V40044	V40244
1137	1136	1135	1134	1133	1132	1131	1130	1127	1126	1125	1124	1123	1122	1121	1120	V40045	V40245
1157	1156	1155	1154	1153	1152	1151	1150	1147	1146	1145	1144	1143	1142	1141	1140	V40046	V40246
1177	1176	1175	1174	1173	1172	1171	1170	1167	1166	1165	1164	1163	1162	1161	1160	V40047	V40247
1217	1216	1215	1214	1213	1212	1211	1210	1207	1206	1205	1204	1203	1202	1201	1200	V40050	V40250
1237	1236	1235	1234	1233	1232	1231	1230	1227	1226	1225	1224	1223	1222	1221	1220	V40051	V40251
1257	1256	1255	1254	1253	1252	1251	1250	1247	1246	1245	1244	1243	1242	1241	1240	V40052	V40252
1277	1276	1275	1274	1273	1272	1271	1270	1267	1266	1265	1264	1263	1262	1261	1260	V40053	V40253
1317	1316	1315	1314	1313	1312	1311	1310	1307	1306	1305	1304	1303	1302	1301	1300	V40054	V40254
1337	1336	1335	1334	1333	1332	1331	1330	1327	1326	1325	1324	1323	1322	1321	1320	V40055	V40255
1357	1356	1355	1354	1353	1352	1351	1350	1347	1346	1345	1344	1343	1342	1341	1340	V40056	V40256
1377	1376	1375	1374	1373	1372	1371	1370	1367	1366	1365	1364	1363	1362	1361	1360	V40057	V40257
1417	1416	1415	1414	1413	1412	1411	1410	1407	1406	1405	1404	1403	1402	1401	1400	V40060	V40260
1437	1436	1435	1434	1433	1432	1431	1430	1427	1426	1425	1424	1423	1422	1421	1420	V40061	V40261
1457	1456	1455	1454	1453	1452	1451	1450	1447	1446	1445	1444	1443	1442	1441	1440	V40062	V40262
1477	1476	1475	1474	1473	1472	1471	1470	1467	1466	1465	1464	1463	1462	1461	1460	V40063	V40263
1517	1516	1515	1514	1513	1512	1511	1510	1507	1506	1505	1504	1503	1502	1501	1500	V40064	V40264
1537	1536	1535	1534	1533	1532	1531	1530	1527	1526	1525	1524	1523	1522	1521	1520	V40065	V40265
1557	1556	1555	1554	1553	1552	1551	1550	1547	1546	1545	1544	1543	1542	1541	1540	V40066	V40266
1577	1576	1575	1574	1573	1572	1571	1570	1567	1566	1565	1564	1563	1562	1561	1560	V40067	V40267
1617	1616	1615	1614	1613	1612	1611	1610	1607	1606	1605	1604	1603	1602	1601	1600	V40070	V40270
1637	1636	1635	1634	1633	1632	1631	1630	1627	1626	1625	1624	1623	1622	1621	1620	V40071	V40271
1657	1656	1655	1654	1653	1652	1651	1650	1647	1646	1645	1644	1643	1642	1641	1640	V40072	V40272
1677	1676	1675	1674	1673	1672	1671	1670	1667	1666	1665	1664	1663	1662	1661	1660	V40073	V40273
1717	1716	1715	1714	1713	1712	1711	1710	1707	1706	1705	1704	1703	1702	1701	1700	V40074	V40274
1737	1736	1735	1734	1733	1732	1731	1730	1727	1726	1725	1724	1723	1722	1721	1720	V40075	V40275
1757	1756	1755	1754	1753	1752	1751	1750	1747	1746	1745	1744	1743	1742	1741	1740	V40076	V40276
1777	1776	1775	1774	1773	1772	1771	1770	1767	1766	1765	1764	1763	1762	1761	1760	V40077	V40277

DL260 Remote I/O (GX) and (GY) Points															GX Address	GY Address	
MSB							LSB										
17	16	15	14	13	12	11	10	7	6	5	4	3	2	1	0		
2017	2016	2015	2014	2013	2012	2011	2010	2007	2006	2005	2004	2003	2002	2001	2000	V40100	V40300
2037	2036	2035	2034	2033	2032	2031	2030	2027	2026	2025	2024	2023	2022	2021	2020	V40101	V40301
2057	2056	2055	2054	2053	2052	2051	2050	2047	2046	2045	2044	2043	2042	2041	2040	V40102	V40302
2077	2076	2075	2074	2073	2072	2071	2070	2067	2066	2065	2064	2063	2062	2061	2060	V40103	V40303
2117	2116	2115	2114	2113	2112	2111	2110	2107	2106	2105	2104	2103	2102	2101	2100	V40104	V40304
2137	2136	2135	2134	2133	2132	2131	2130	2127	2126	2125	2124	2123	2122	2121	2120	V40105	V40305
2157	2156	2155	2154	2153	2152	2151	2150	2147	2146	2145	2144	2143	2142	2141	2140	V40106	V40306
2177	2176	2175	2174	2173	2172	2171	2170	2167	2166	2165	2164	2163	2162	2161	2160	V40107	V40307
2217	2216	2215	2214	2213	2212	2211	2210	2207	2206	2205	2204	2203	2202	2201	2200	V40110	V40310
2237	2236	2235	2234	2233	2232	2231	2230	2227	2226	2225	2224	2223	2222	2221	2220	V40111	V40311
2257	2256	2255	2254	2253	2252	2251	2250	2247	2246	2245	2244	2243	2242	2241	2240	V40112	V40312
2277	2276	2275	2274	2273	2272	2271	2270	2267	2266	2265	2264	2263	2262	2261	2260	V40113	V40313
2317	2316	2315	2314	2313	2312	2311	2310	2307	2306	2305	2304	2303	2302	2301	2300	V40114	V40314
2337	2336	2335	2334	2333	2332	2331	2330	2327	2326	2325	2324	2323	2322	2321	2320	V40115	V40315
2357	2356	2355	2354	2353	2352	2351	2350	2347	2346	2345	2344	2343	2342	2341	2340	V40116	V40316
2377	2376	2375	2374	2373	2372	2371	2370	2367	2366	2365	2364	2363	2362	2361	2360	V40117	V40317
2417	2416	2415	2414	2413	2412	2411	2410	2407	2406	2405	2404	2403	2402	2401	2400	V40120	V40320
2437	2436	2435	2434	2433	2432	2431	2430	2427	2426	2425	2424	2423	2422	2421	2420	V40121	V40321
2457	2456	2455	2454	2453	2452	2451	2450	2447	2446	2445	2444	2443	2442	2441	2440	V40122	V40322
2477	2476	2475	2474	2473	2472	2471	2470	2467	2466	2465	2464	2463	2462	2461	2460	V40123	V40323
2517	2516	2515	2514	2513	2512	2511	2510	2507	2506	2505	2504	2503	2502	2501	2500	V40124	V40324
2537	2536	2535	2534	2533	2532	2531	2530	2527	2526	2525	2524	2523	2522	2521	2520	V40125	V40325
2557	2556	2555	2554	2553	2552	2551	2550	2547	2546	2545	2544	2543	2542	2541	2540	V40126	V40326
2577	2576	2575	2574	2573	2572	2571	2570	2567	2566	2565	2564	2563	2562	2561	2560	V40127	V40327
2617	2616	2615	2614	2613	2612	2611	2610	2607	2606	2605	2604	2603	2602	2601	2600	V40130	V40330
2637	2636	2635	2634	2633	2632	2631	2630	2627	2626	2625	2624	2623	2622	2621	2620	V40131	V40331
2657	2656	2655	2654	2653	2652	2651	2650	2647	2646	2645	2644	2643	2642	2641	2640	V40132	V40332
2677	2676	2675	2674	2673	2672	2671	2670	2667	2666	2665	2664	2663	2662	2661	2660	V40133	V40333
2717	2716	2715	2714	2713	2712	2711	2710	2707	2706	2705	2704	2703	2702	2701	2700	V40134	V40334
2737	2736	2735	2734	2733	2732	2731	2730	2727	2726	2725	2724	2723	2722	2721	2720	V40135	V40335
2757	2756	2755	2754	2753	2752	2751	2750	2747	2746	2745	2744	2743	2742	2741	2740	V40136	V40336
2777	2776	2775	2774	2773	2772	2771	2770	2767	2766	2765	2764	2763	2762	2761	2760	V40137	V40337

DL260 Remote I/O (GX) and (GY) Points																GX Address	GY Address
MSB								LSB									
17	16	15	14	13	12	11	10	7	6	5	4	3	2	1	0		
3017	3016	3015	3014	3013	3012	3011	3010	3007	3006	3005	3004	3003	3002	3001	3000	V40140	V40340
3037	3036	3035	3034	3033	3032	3031	3030	3027	3026	3025	3024	3023	3022	3021	3020	V40141	V40341
3057	3056	3055	3054	3053	3052	3051	3050	3047	3046	3045	3044	3043	3042	3041	3040	V40142	V40342
3077	3076	3075	3074	3073	3072	3071	3070	3067	3066	3065	3064	3063	3062	3061	3060	V40143	V40343
3117	3116	3115	3114	3113	3112	3111	3110	3107	3106	3105	3104	3103	3102	3101	3100	V40144	V40344
3137	3136	3135	3134	3133	3132	3131	3130	3127	3126	3125	3124	3123	3122	3121	3120	V40145	V40345
3157	3156	3155	3154	3153	3152	3151	3150	3147	3146	3145	3144	3143	3142	3141	3140	V40146	V40346
3177	3176	3175	3174	3173	3172	3171	3170	3167	3166	3165	3164	3163	3162	3161	3160	V40147	V40347
3217	3216	3215	3214	3213	3212	3211	3210	3207	3206	3205	3204	3203	3202	3201	3200	V40150	V40350
3237	3236	3235	3234	3233	3232	3231	3230	3227	3226	3225	3224	3223	3222	3221	3220	V40151	V40351
3257	3256	3255	3254	3253	3252	3251	3250	3247	3246	3245	3244	3243	3242	3241	3240	V40152	V40352
3277	3276	3275	3274	3273	3272	3271	3270	3267	3266	3265	3264	3263	3262	3261	3260	V40153	V40353
3317	3316	3315	3314	3313	3312	3311	3310	3307	3306	3305	3304	3303	3302	3301	3300	V40154	V40354
3337	3336	3335	3334	3333	3332	3331	3330	3327	3326	3325	3324	3323	3322	3321	3320	V40155	V40355
3357	3356	3355	3354	3353	3352	3351	3350	3347	3346	3345	3344	3343	3342	3341	3340	V40156	V40356
3377	3376	3375	3374	3373	3372	3371	3370	3367	3366	3365	3364	3363	3362	3361	3360	V40157	V40357
3417	3416	3415	3414	3413	3412	3411	3410	3407	3406	3405	3404	3403	3402	3401	3400	V40160	V40360
3437	3436	3435	3434	3433	3432	3431	3430	3427	3426	3425	3424	3423	3422	3421	3420	V40161	V40361
3457	3456	3455	3454	3453	3452	3451	3450	3447	3446	3445	3444	3443	3442	3441	3440	V40162	V40362
3477	3476	3475	3474	3473	3472	3471	3470	3467	3466	3465	3464	3463	3462	3461	3460	V40163	V40363
3517	3516	3515	3514	3513	3512	3511	3510	3507	3506	3505	3504	3503	3502	3501	3500	V40164	V40364
3537	3536	3535	3534	3533	3532	3531	3530	3527	3526	3525	3524	3523	3522	3521	3520	V40165	V40365
3557	3556	3555	3554	3553	3552	3551	3550	3547	3546	3545	3544	3543	3542	3541	3540	V40166	V40366
3577	3576	3575	3574	3573	3572	3571	3570	3567	3566	3565	3564	3563	3562	3561	3560	V40167	V40367
3617	3616	3615	3614	3613	3612	3611	3610	3607	3606	3605	3604	3603	3602	3601	3600	V40170	V40370
3637	3636	3635	3634	3633	3632	3631	3630	3627	3626	3625	3624	3623	3622	3621	3620	V40171	V40371
3657	3656	3655	3654	3653	3652	3651	3650	3647	3646	3645	3644	3643	3642	3641	3640	V40172	V40372
3677	3676	3675	3674	3673	3672	3671	3670	3667	3666	3665	3664	3663	3662	3661	3660	V40173	V40373
3717	3716	3715	3714	3713	3712	3711	3710	3707	3706	3705	3704	3703	3702	3701	3700	V40174	V40374
3737	3736	3735	3734	3733	3732	3731	3730	3727	3726	3725	3724	3723	3722	3721	3720	V40175	V40375
3757	3756	3755	3754	3753	3752	3751	3750	3747	3746	3745	3744	3743	3742	3741	3740	V40176	V40376
3777	3776	3775	3774	3773	3772	3771	3770	3767	3766	3765	3764	3763	3762	3761	3760	V40177	V40377