

Honeywell Precision Barometer

HPB & HPA (RS-232, RS-485 Output)



User's Manual

Version 2.4C5

ADS-14085 Rev. 11/02

Customer Service Representative

(800) 323-8295 fax: (763) 954-2257

E-Mail: ssec.customer.service@honeywell.com

Web Site: www.ssec.honeywell.com

No part of this manual may be reproduced or transmitted in any form or by any means, electronic or mechanical, including photocopying and recording, for any purpose, without the express written permission of Honeywell, Inc. Honeywell reserves the right to make changes to any products or technology herein to improve reliability, function or design. Honeywell does not assume any liability arising out of the application or use of any product or circuit described herein; neither does it convey any license under its patent rights nor the rights of others.

©Copyright 2002 Honeywell Inc., All rights reserved. Printed in U.S.A.

Table of Contents

0 USER'S MANUAL CONTENT	1
1 INTRODUCTION	2
1.1 PRODUCT OVERVIEW	2
1.2 HARDWARE DESCRIPTION	2
2 GETTING STARTED	3
2.1 OVERVIEW	3
2.2 EQUIPMENT NEEDED	3
2.3 TERMINAL PROGRAM SETTINGS	3
2.4 INITIAL TURN-ON RESPONSE	4
2.5 COMMAND FORMAT	4
2.6 STEP-BY-STEP EXAMPLES (Only for single HPB connection)	4
2.7 COMMAND FUNCTIONAL GROUPS	6
3 COMMANDS—QUICK REFERENCE	9
4 FUNCTIONAL OPERATION	12
4.1 OVERVIEW	12
4.2 WHAT IS INTEGRATION?	12
4.3 PRESSURE READING CONTROL	13
4.4 CUSTOMIZED PRESSURE RANGE	15
4.5 COMMAND ILLUSTRATIONS	16
4.6 PRESSURE READING DECIMAL POSITION	19
4.7 HPB ADDRESSING	20
5 COMMANDS	24
5.1 COMMAND FORMAT	24
5.2 INFORMATION REQUEST COMMANDS	24
5.3 ACTION DIRECTING COMMANDS	25
5.4 COMMAND REPLIES – GENERAL	25
5.5 ASCII FORMAT REPLIES	26
5.6 BINARY FORMAT REPLIES	27
5.7 COMMAND AND REPLY SEQUENCING	29
5.8 COMMAND ERRORS	30
5.9 COMMAND SUMMARY TABLE	31
5.10 COMMAND DESCRIPTIONS	33
6 ELECTRICAL CONNECTIONS	61
7 TIMING DIAGRAMS	63
8 SPECIFICATIONS	66
9 DIMENSIONS	68

Figures

Figure 4.1—HPB Block Diagram	12
Figure 4.2—Pressure Reading Control	14
Figure 4.3—Custom Slope (X=) Options	15
Figure 4.4—Custom Offset (Z=) Options	15
Figure 4.5—Integration (I=) Command, Example 1	16
Figure 4.6—Integration (I=) Command, Example 2	16
Figure 4.7—S2 Speed Shift Command Example	17
Figure 4.8—S5 Speed Shift Command Example	17
Figure 4.9a—Deadband and Sensitivity (DS) Command Examples	18
Figure 4.9b—Deadband and Sensitivity (DS) Command Examples	18
Figure 4.10—Idle Count (IC) Command Example	18
Figure 4.11—Synchronize Integration Cycles (SI) Command Example	19
Figure 4.12—HPB RS-232 Ring Network	20
Figure 4.13—HPB RS-485 Multidrop Network	22
Figure 5.1—Single HPB Command and Reply	29
Figure 5.2—Multiple HPB Network Command and Replies	30
Figure 6.1—HPB RS-232/485 and HPB-CE Electrical Connector Pin Assignments	61
Figure 6.2—Connection for RS-232 Operation	61
Figure 6.3—Connection for RS-485 Operation	62
Figure 7.1—Default Single Pressure Reading Timing Diagram	63
Figure 7.2—Default Continuous Pressure Reading Timing Diagram	63
Figure 7.3—Continuous Pressure (with IC = 1) Timing Diagram	63
Figure 7.4—Timing Diagram for 20 Readings Per Second	64
Figure 7.5—Timing Diagram for 50 Readings Per Second	64
Figure 7.6—Timing Diagram for 120 Readings Per Second	64
Figure 9.1a—HPB Case Outline Standard	68
Figure 9.1b—HPB Case Outline CE Mark	68
Figure 9.2—Electrical Connector	68

Tables

Table 1.1—Various Digital Modes 2
Table 4.1—Decimal Place Locations for Pressure Readings.....	. 19
Table 5.1—Header Description for Binary Format Pressure Readings 27
Table 5.2—Binary Format Character Codes 27
Table 5.3—Command List 32
Table 5.4—Factory Default Command Responses 34
Table 5.5—Display Units Options 41
Table 7.1—Transmission Times at Selected Baud Rate 65
Table 7.2—Number of Bytes in Various Replies 65
Table 9.1—ASCII Conversion Table, Decimal to Hexadecimal 69
Table 9.2—RS-232 Standard Pin Connections.....	. 69
Table 9.3—Electrical Signal Levels 69

0 USER'S MANUAL CONTENT

This user's manual is divided into the following sections.

Section 1	Introduction —Product overview and hardware description.
Section 2	Getting Started —Lists equipment and procedures necessary to operate the HPB and provides a few simple command examples, which will get first-time users acquainted with the command structure.
Section 3	Commands: Quick Reference —A brief description of each command with typical HPB input and response examples.
Section 4	Functional Operation
Section 5	Commands —Contains a detailed description of the command structure, functional groupings and all user commands.
Section 6	Electrical Connections —Contains wiring diagrams for various HPB electrical connections.
Section 7	Timing Diagrams —Illustrates RS-232 serial port timing for command and reply interaction.
Section 8	Specifications —Contains electrical and environmental specifications.
Section 9	Dimensions —Contains a case outline of the HPB

It is suggested that the first-time user read the “Getting Started” section to be sure the necessary items are on hand. Be sure to connect a source of pressure that matches the transducer range.

1 INTRODUCTION

1.1 PRODUCT OVERVIEW

The Honeywell Precision Barometer RS-232 and Honeywell Precision Barometer RS-485* (HPB) provides high accuracy absolute pressure readings in digital form. The first-time user will be able to use the HPB within minutes, yet capability exists to configure the HPB for optimum performance in specific applications.

The heart of the HPB measuring system is a silicon piezoresistive sensor, which contains both pressure and temperature-sensitive elements. Digital signals representing temperature and pressure are processed by a microprocessor to produce fully temperature compensated and calibrated pressure readings over the entire -40 to 85°C temperature range.

Any computer having a serial port and terminal emulation software can be connected to the HPB to allow the user to select baud rates, sample rates, readout resolution, units of pressure and other choices. RS-485 versions require an RS-485 to RS-232 converter or and RS-485 port on the computer.

User selected functions are set through the digital interface. The selected functions may either be used temporarily, until the HPB is powered down, or may be stored in the internal EEPROM to automatically configure the HPB each time power is applied. The output modes are shown in Table 1.1.

The HPB receives commands and sends data from either an RS-232 port or a multidrop RS-485 port. Using the RS-232 type HPB, up to 89 units can be connected in a ring configuration to a single serial port of a computer. The RS-485 type HPB allows up to 89 HPBs to be connected to a two-wire multidrop bus, when bus repeaters are used to satisfy the RS-485 bus electrical requirements. Group (multicast) addressing allows up to nine groups of HPBs to be addressed with a single command. Global (broadcast) addressing will send a command to all HPBs on the serial bus.

Digital Output
Single or Continuous Pressure Readings
Single or Continuous Temperature Readings

Table 1.1—Various Digital Modes

1.2 HARDWARE DESCRIPTION

See Sections 8 and 9.

* For simplicity, references throughout this manual HPB-RS-232, HPB-RS-485, HPA-RS-232 & HPA-RS-485 have been shortened to HPB.

2 GETTING STARTED

2.1 OVERVIEW

The first-time user should approach the HPB in a manner analogous to using a word processor program; i.e., many features are available but one may begin by using those of interest at the moment. Section 2.7 of this manual lists command features by functional groups to assist in this selection. When shipped from the factory, the default settings provide a pressure transducer that will be usable for many applications. Once the user is familiar with the performance and command structure, changes may be made and stored using the 'Store Parameters' (SP) command. Once stored, the new default settings are activated each time the HPB is powered up. This tailors the personality of the HPB to meet the needs of a particular application.

2.2 EQUIPMENT NEEDED

To prepare the HPB for operation, four items are needed:

- A mating connector with proper wiring connections (see connector part number and wiring diagram in Section 6—Electrical Connections);
- A DC power supply;
- A source of pressure that is properly matched to the range of the HPB.
- A computer, or host processor, having an RS-232 or RS-485 serial port and terminal program software such as PROCOM™, VERSATERM™, TERMINAL (Windows® 3.x) or HYPERTERMINAL (Windows® 95). These programs are normally used to interface to a modem. The wiring diagram designates which HPB pins must connect to the computer “send”, “receive” and “common” pins for proper communications. Some computers may not have an RS-232 or RS-485 serial port connection identical to the one shown in Section 6, making it necessary to adapt the HPB connections to that particular computer.

A link to Honeywell demonstration software is available at www.pressuresensing.com.

2.3 TERMINAL PROGRAM SETTINGS

- Enter the following settings in the terminal program:

```
Baud Rate ..... 9600
Start Bits ..... 1
Data Bits ..... 8
Stop Bits ..... 1
Parity ..... None
```

- Attach a line feed to the carriage return.
- Turn the local echo ON.

When shipped from the factory, the HPB is set to a baud rate of 9600, 1 start bit, 8 data bits with no parity and one stop bit. If the baud rate has been subsequently changed, and is unknown, it will be necessary to search all baud rate values to reestablish communication. See the BP command description in Section 5.10 of this manual for possible settings.

2.4 INITIAL TURN-ON RESPONSE

Once the wiring connections and terminal program settings are complete, the HPB will automatically send the following response (or similar to) when power is applied. This reply will be generated any time power is applied to the HPB.

Typical Reply:

```
?01HPB__1200mBAR RS-232
?00HPB__1200mBAR RS-485
```

The “?01” or “?00” indicates a default address device called a “null address”. This HPB has not yet been assigned an ID number so it assumes the null address.

2.5 COMMAND FORMAT

Any command interaction with the HPB requires electrical connection to the RS-232 or RS-485 serial communications pins. There are two basic types of commands: action directing commands and information requesting commands. These commands are described in Section 5.

Typical HPB commands have the form ***ddcc = nnn <cr>**

Where:	*	is the command header character
	dd	is the decimal address of the HPB
	cc	is a command (refer to Commands – Section 5 for a complete description of commands)
	=	equal sign (required in some commands)
	nnn	additional characters (required in some commands)
	<cr>	carriage return is required to end all commands (do not type, press the ENTER/RETURN key)

2.6 STEP-BY-STEP EXAMPLES *(Only for single HPB connection)*

The following examples assume that the reader has followed them in order.

• READ SINGLE PRESSURE

Once the HPB is powered up and connected to a computer, enter the following command:

```
Type:   *00P1 <cr>   Response:  ?01CP=15.458 (for RS-232)
                                     ?00CP=15.458 (for RS-485)
```

where * indicates the start of a command
00 is the null address of the HPB (see note below)
P1 is the command to read the most current pressure

Note: The “?” indicates a response from a null address HPB – one which has not been assigned a device ID. A null address, 00, is coded into each HPB at the factory. When an RS-232 null address HPB responds, it adds one to its address, hence, the response ‘01’. Refer to the **ID** command in Appendix A for a description of addresses and responses.

In the reply, the “01” identifies the individual unit address (range 01-89). The “CP=15.458” indicates a compensated pressure of 15.458 psi. Your unit may not show this specific reading, depending on the applied pressure it is measuring.

- **SET DEVICE ID**

To give the HPB an assigned address of 01 up to 89, enter the following commands:

Type: *00WE <cr> This enables the HPB to change a parameter in RAM

Type: *00ID=01 <cr> This sets the null addressed HPB to device ID=01.

Note: The device ID is now used in the command input

Type: *01S= <cr> **Response:** #01S=00052036 (serial number test)

The “#” now replaces the “?” in the header and indicates the HPB response is from an address assigned unit.

where: * indicates the start of a command
 00 is the null address of the HPB
 WE is the command to enable a configuration parameter change
 ID is the command to change the device address
 01 is the assigned HPB address for this example
 S= is the command to read the serial number

- **READ PRODUCTION DATE**

To read the production date, enter the following command:

Type: *01P= <cr> **Response:** #01P=11/15/02

(Actual response depends on production date of device being used.)

- **READ CONTINUOUS PRESSURE**

For continuous pressure readings at the factory set default rate of 5 per second, enter the following command:

Type: *01P2 <cr> This enables a continuous stream of compensated pressure readings to flow into the terminal program.

Type: \$*99IN <cr> This is the best way to stop the continuous pressure reading commands. The ‘\$’ character temporarily stops, or suspends, either the continuous pressure or temperature readings. The *99IN command stops the continuous pressure readings.

- **CHANGE TO A NEW SAMPLE RATE**

Enter the following command:

Type: *01WE <cr> This enables the HPB RAM to accept a changed parameter.

Type: *01I=M20<cr> This sets the integration time to value 20, which corresponds to an output sample every 2 seconds.

The sample rate will change to one every 2 seconds. **I=** is an abbreviation for Integration time which determines how long to accumulate pressure samples between readings. Each integration period gathers the data for one pressure reading output (see Section 4.2 What is integration?). The range of integration times can be set by specifying readings per second (I=R45 for 45 readings/sec) or time delay in 100 millisecond intervals (I=M60 for 6 seconds). The factory set integration time is 5 samples per second (I=M2).

The output data rate can also be altered by use of the idle count (**IC**) command or by using the reading rate (**RR**) command in conjunction with the operating mode (**OP**) command. See Section 4 for description of these commands.

- **REPEAT THE READ CONTINUOUS PRESSURE STEP ABOVE**

Notice the slower output rate of one sample every 2 seconds.

- **TRY OTHER COMMANDS**

Experiment with other commands to become familiar with the command structures. A short overview of each command with input and response examples is shown in Section 3 Commands – Quick Reference. See Section 5—Commands for complete command descriptions. Re-apply the power or send an **IN=RESET** command to revert to EEPROM default settings. Until an **SP=ALL** command is executed, no changes will be stored in the EEPROM.

2.7 COMMAND FUNCTIONAL GROUPS

- **PRESSURE DISPLAY UNITS** —*HPB reads out psi, in wc, mm Hg, etc.*

DU Set pressure units for output readings—any one of 13 common units (See Section 8)
U= Specify a user supplied unit of measure

- **TEMPERATURE**

T1 Single °C
T2 Continuous °C
T3 Single °F
T4 Continuous °F

- **RS-232/RS-485 BUS PARAMETERS**

BP Changes baud rate and parity
ID Assign device ID and group addresses
M= Select alternate message Headers [RS-485 only]
SI Synchronize Integration cycles among units [RS-485 only]
TO Set Transceiver Operating parameters

- **OUTPUT READING AND RATE**—*Speed up or slow down output rate*

Single Reading Commands

P1 Single pressure reading...ASCII format
P3 Single pressure reading...binary format
T1 Single temperature reading...°C
T3 Single temperature reading...°F

Continuous Readings Commands

P2 Continuous pressure readings...ASCII format
P4 Continuous pressure readings...binary format
T2 Continuous temperature readings...°C
T4 Continuous temperature readings...°F

Integration Time Commands —*Changes pressure reading response time*

- DS Set deadband and sensitivity parameters
- I= Set pressure integration time, and sampling rate
- S2 Set threshold level for 2X speed shift
- S5 Set threshold level for output within any 50 msec period
- SI Synchronize pressure Integration cycles

Idle Count Command —*Changes pressure reading response time*

- IC Set number of idle integration cycles

Reading Response To Changes In Input Pressure—*Filters small changes*

- S2 Set threshold level for 2X speed shift
- S5 Set threshold level for output within any 50 msec period
- RR Set number of identical readings to skip
- OP Transmit all readings or only changed readings

- **FORMAT PRESSURE READINGS**—*Changes data length into host processor*

Binary Format Commands

- P3 Single RS-232 pressure...binary format
- P4 Continuous RS-232 pressure...binary format
- OP Set operating mode...binary format checksum...set signed or extended binary output format

ASCII Format Commands

- All readings, except P3 and P4, are ASCII format readings.
- OP Set operating mode...all readings or only changed readings

- **START-UP PARAMETERS**—*Sets the HPB configuration after power is applied*

- WE Enable parameter writes to the RAM or EEPROM
- SP Store RAM parameters to the EEPROM for startup
- MO Specify the power-up message and operating mode

- **PRESSURE NOISE REDUCTION**—*Reduces pressure noise signals*

- DS Set deadband and sensitivity parameters

- **DIAGNOSTIC AND RESET CONTROL**

- IN Performs a software reset of microprocessor
- RS Read status of error indicators
- CK Performs and provides the result of EEPROM checksum
- OP Use pressure reading checksum for binary format

- **USER AND STARTUP MESSAGES**

- A= Store 8 characters of user supplied data
- B= Store 8 characters of user supplied data
- C= Store 8 characters of user supplied data, which can be configured as a watchdog or reset message
- D= Store 8 characters of user supplied data, which can be configured as a watchdog or reset message
- MO Specify the startup header selection

- **HPB UNIT INFORMATION**

- P= HPB production date
- S= HPB serial number
- V= HPB software version number
- ID Assign device ID and group addresses
- M= Read the maximum full scale pressure limit allowed

- **CUSTOMIZE PRESSURE WINDOW**
 - F= Customize the full scale pressure limit
 - X= Set the slope “m” parameter for user input $mx+b$ control
 - Z= Set the offset “b” parameter for user input $mx+b$ control

3 COMMANDS—QUICK REFERENCE

		Example Input (1)	Example Response (2)
A=	Data String A (up to 8 characters, a <cr> indicates end-of-message. More than 8 characters is an invalid write) (Can store info. such as dates, readings, etc.)	Write string A Inquiry	*00WE *00A=2-8-95 ?01A=2-8-95
BP	Baud Rate and Parity Setting	Set parameters (no parity, 1200 baud)	*99WE *99BP=N1200
B=	Data String B (up to 8 characters, a <cr> indicates end-of-message, and more than 8 characters will not write to location) (Can store info. such as dates, readings, etc.)	Write string B Inquiry	*00WE *00B=123.4567 ?01B=123.4567
CK	Check EEPROM	Inquiry	*00CK ?01CK=OK
C=	Data String C (up to 8 characters, a <cr> indicates end-of-message, and more than 8 characters will not write to location) The C and D string can be used for a watchdog or reset message (see MO command).	Write string C Inquiry	*00WE *00C=This_is_ ?01C=This_is_
DO	Default Operating Parameters	Set DO parameters (factory default setting) Inquiry	*00WE *00DO=E ?01DO=E0N
DS	Deadband and Sensitivity Control (set deadband to 20 x 0.005% = 0.10%FS)	Set DS parameters Inquiry	*00WE *00DS=20 ?01DS=00S0
DU	Display Units Control	Set DU parameters (set units to in. Hg) Inquiry	*00WE *00DU=INHG ?01DU=INHG
D=	Data String D (up to 8 characters, a <cr> indicates end-of-message, and more than 8 characters will not write to location) The C and D string can be used for a watchdog or reset message (see MO command).	Write string D Inquiry	*00WE *00D=A_HPB!!! ?01D=A_HPB!!!
F=	Custom Full Scale Range	Set F= parameter (set custom FS range to 10.5psi) Inquiry	*00WE *00F=10.5 ?01F=10.500
IC	Idle Count Parameter (set idle count to 12 , so that 12 output samples are skipped)	Set IC parameter Inquiry	*00WE *00IC=12 ?01IC=12

(1) A carriage return, <cr>, should follow each input. If the HPB has an established address of 12, for instance, then begin the command with *12.. instead of *00...

(2) The responses shown here begin with ?01.. and are for a null address HPB. That is, an HPB that has not yet established unit identification (see ID command). If the HPB has an assigned address of 23, for instance, the response will begin with #23.. instead of ?01...

Note: See Section 5.10 for complete command descriptions.

ID	Identification Number	Set ID number	*00WE	
		(set device ID of first null addressed unit to 12)	*00ID=12	
		Confirmation of ID=12	*12P1	#12CP= 14.32
		Set group number	*12WE	
		[RS-232] (set group ID of unit 12 to 95)	*12ID=95	
	[RS-232] Group no. inquiry of device ID=12	*12ID	#12ID=95	
	[RS-485](set group ID of unit 12 to 95 with group sub-address of 01)	*12ID=9501		
	[RS-485] Group no. inquiry of device ID=12	*12ID	#12ID=9501	
IN	Initialize HPB Microprocessor	Stop all current operations	*99IN	
		(does not affect RAM data)		
		Full reset of HPB processor	*99IN=reset	
	Changes to RAM data are lost unless an SP =ALL command was previously issued. (Response is user message, if selected)	?01Pressure_tank_1		
I=	Integration time	Set I parameter	*00WE	
		(set output rate to 50 readings/second)	*00I=R50	
		Inquiry	*00I=	?01I=R050
MO	Power Up Mode	Set MO parameter	*00WE	
			*00MO=M1	
		Required to save in EEPROM for power-up	*00WE	
		*00SP=ALL		
	Inquiry	*00MO	?01MO=X2M1	
OP	Operating Mode Parameters	Set OP parameter	*00WE	
		(set to extended binary output mode)	*00OP=E	
		Inquiry	*00OP	?01OP=ANEW
P1	Pressure, Single, ASCII Format	Request compensated pressure	*00P1	?01CP= 14.450
P2	Pressure, Continuous, ASCII Format	Request compensated pressure	*00P2	?01CP= 14.450 (repeated)
P3	Pressure, Single, Binary Format	Compensated pressure (null address)	*00P3	^@PSA or
		Compensated pressure (assigned address)	*01P3	{ @PSA
		(typical response is a ^ or { char plus 4 data bytes that are encoded for computer translation)		
P4	Pressure, Continuous, Binary Format	Compensated pressure (null address)	*00P4	^@P@@ or
		Compensated pressure (assigned address)	*01P4	{ @P@@
		(typical response is a ^ or { char plus 4 data bytes that are encoded for computer translation)		(repeated)
P=	Production Date	(factory set date, mm/dd/yy) Inquiry	*00P=	?01P=06/13/02
RR	Reading Rate	Set RR parameter	*00WE	
		(skip 5 x 100 = 500 readings if identical)	*00RR=5	
		Inquiry	*00RR	?01RR=5
RS	Read Status	Inquiry	*00RS	?01RS=0000

Note: See Section 5.10 for complete command descriptions.

S2	Speed Shift to 2X	Set S2 parameter <i>(shift to double speed if pressure changes more than 12* 0.01%FS = 0.12% FS)</i>	*00WE *00S2=12	
		Inquiry	*00S2	?01S2=12
S5	Speed Shift at 50msec Intervals	Set S5 parameter <i>(Output reading if pressure changes more than 60 * 0.01%FS = 0.6% FS)</i>	*00WE *00S5=60	
		Inquiry	*00S5	?01S5=60
SI	Synchronize Pressure Integration	Synchronize Integration	*01SI	
SP	Store Parameters in EEPROM	Store parameter <i>(store all settings stored in RAM in EEPROM)</i>	*00WE *00SP=ALL	
S=	Serial Number			
		Inquiry	*00S=	?01S=00032000
T1	Temperature, Single, °C	Request Celsius temperature	*00T1	?01CT= 24.5 or ?01CT= ..
T2	Temperature, Continuous, °C	Request Celsius temperature	*00T2	?01CT= 24.5 (repeated)
T3	Temperature, Single, °F	Request Fahrenheit temperature	*00T3	?01FT= 76.1 or ?01FT= ..
T4	Temperature, Continuous, °F	Request Fahrenheit temperature	*00T4	?01FT= 76.1 (repeated)
TO	Transceiver Operating Parameters	Set RS-485 response delay to 2 character times	*01 WE *01TO=2	
		Inquiry	*01TO	#01TO=M2CN
U=	User Supplied Display Units	Set display units <i>(set units to 5.1 x psi)</i> Activate user display units	*00WE *00U=5.100 *00WE *00DU=USER	
		Inquiry	*00U=	?01U=5.1000
V=	Version Number			
		Inquiry	*00V=	?01V=02.3B6S2V
WE	Write Enable to EEPROM or RAM	Write several RAM parameters <i>(example to set output units to cm water column)</i> <i>(factory default setting)</i> <i>(Cancel continuous WE=RAM command)</i>	*01WE=RAM *01DU=CMWC *01DO=D *01WE=OFF	
<i>Note: Any command changes in RAM will be lost when the HPB is powered down unless an SP command saves them to EEPROM.</i>				
X=	Slope- User Compensation Control	Set X= parameter <i>(set user slope control to 0.005% x 17 = 0.085%FS)</i>	*00WE *00X=17	
		Inquiry	*00X=	?01X=17
<i>Note: The input slope and offset control are for user supplied mx+b correction.</i>				
Z=	Offset - User Compensation Control	Set Z= parameter <i>(set mx+b pressure offset to 20 x 0.005%FS = 0.1%FS)</i> <i>(null adjust output at zero pressure)</i>	*00WE *00Z=20 *00Z=CAL	
		Inquiry	*00Z=	?01Z=20

Note: See Section 5.10 for complete command descriptions.

4 FUNCTIONAL OPERATION

4.1 OVERVIEW

The HPB is based on a silicon piezoresistive sensor coupled with a microprocessor and other electronic circuitry. The piezoresistive sensor contains both pressure sensitive and temperature sensitive elements which, when modeled over a matrix of pressures and temperatures at the factory, provides a digitally compensated pressure reading. The HPB has an accuracy of 0.03% of full scale (FS) over a -40 to +85°C temperature range. This accuracy is achieved by compensation algorithms in the microprocessor. Because of the internal digital circuitry, having a digital output capability is straight forward. The digital readings are transmitted via RS-485 signals or RS-232 signals, which are commonly available on most personal computers. When connected to a computer, the user can modify the pressure reading rate, integration times, units of pressure, thresholds for deadbands and more.

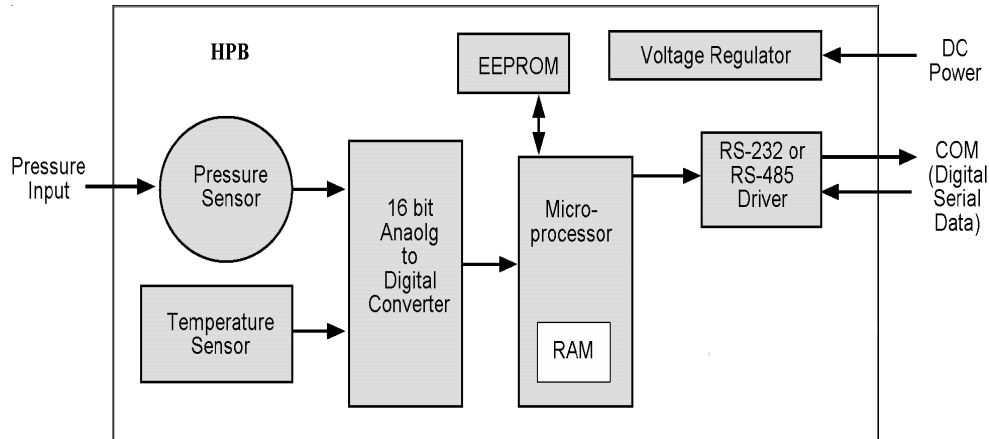

Figure 4.1—HPB Block Diagram

The HPB can be tailored to specific application requirements. Configuration information is sent to, or read from, the HPB by user command messages over the serial port. Any configuration parameter that can be changed by a command may be retrieved by use of that same command except baud rate or parity. Commands used to change parameters must be preceded by an enabling command (**WE** or **NE**), but commands used to retrieve information do not require an enable. All configuration changes are stored in the HPB RAM for immediate use until power is removed. These configuration changes are only made permanent in the EEPROM when the user executes the Write Enable (**WE**) command followed by the EEPROM Store Parameters (**SP**) command. Exceptions to this are the **A=**, **B=**, **C=**, and **D=** commands which are immediately stored to EEPROM if preceded by the **WE** command.

4.2 WHAT IS INTEGRATION?

The input pressure is converted to an analog electrical signal at the pressure sensor. This signal feeds into a delta-sigma analog-to-digital (A/D) converter where it is changed into a digital signal representing the pressure value. During the A/D conversion cycle, the signal is integrated over time. That is, the pressure reading is averaged (integrated) over the A/D conversion cycle so the resultant digital value is the summation of the average pressures observed during the cycle. This conversion cycle is controlled by the user with the Deadband and Sensitivity (**DS**), Synchronization Integration (**SI**), Idle Count (**IC**), and Integration (**I=**) commands.

4.3 PRESSURE READING CONTROL

The HPB commands allow considerable flexibility in tailoring pressure acquisition times, sample windows, thresholds, and output rates. These are controlled by 7 commands: Deadband and Sensitivity (**DS**), Integration (**I=**), Speed shift (**S2**), Speed shift at 50msec intervals (**S5**), Idle Count (**IC**), Reading Rate (**RR**), and OPerating mode (**OP**). Figure 4.2 illustrates how the user may control these attributes in three ways:

First, the internal analog-to-digital converter integration time may be controlled over a range of 1 sample every 12 seconds up to 120 samples per second. This is controlled using the 'Integration' (**I=**) command. The integration time is used to control the A/D integration cycle that allow noisy pressure inputs to be filtered, or averaged, over a selected period of time. See Figures 4.5 and 4.6. The integration time can be set within a range of 1 to 120 samples/sec using the **I=Rn** form or a range of 100msec to 12 sec/sample using the **I=Mn** form. The values for 'n' range from 1 to 120 for both the rate (**Rn**) form and the millisecond (**Mn**) form.

The speed shift commands can only be enabled when the integration time is set using the **I=Mn** form. When enabled, the thresholds for pressure change can be set that cause the output rate to double (**S2**) or update at 50 msec intervals (**S5**). When the change of input pressure reaches or exceeds the threshold, the sample rate shifts to the higher rate.

Second, the integration cycles may be spaced with idle periods that cause pressure reading times to increase to as often as one every 51 minutes. The Idle Count (**IC**) command will insert, or skip, from 0 to 255 idle periods equal to the integration time. If the integration time is set to the maximum, 12 sec/sample, and an idle count of 255 is selected, then the time between samples = 12 sec. x 256 = 51.2 minutes.

Third, the reading rate may be controlled so pressure readings are obtained only when pressure changes occur. The Reading Rate (**RR**) command can be set to only output changed readings, or to skip from 100 to 1000 identical readings. The Operating Mode command (**OP**) can be set to output every reading or to only output readings when a pressure change occurs. The Deadband setting in the **DS** command can filter a small pressure change by not allowing the pressure reading to vary as long as it remains within the deadband limits. This controls the sensitivity to change of the **RR** and **OP** command modes when the 'output only when pressure changes' options are selected. If the pressure signal is stable within the deadband limit, then the pressure reading time can be increased up to 1000 times the integration time by using the **RR** command.

HPB Pressure Rate Conditioning

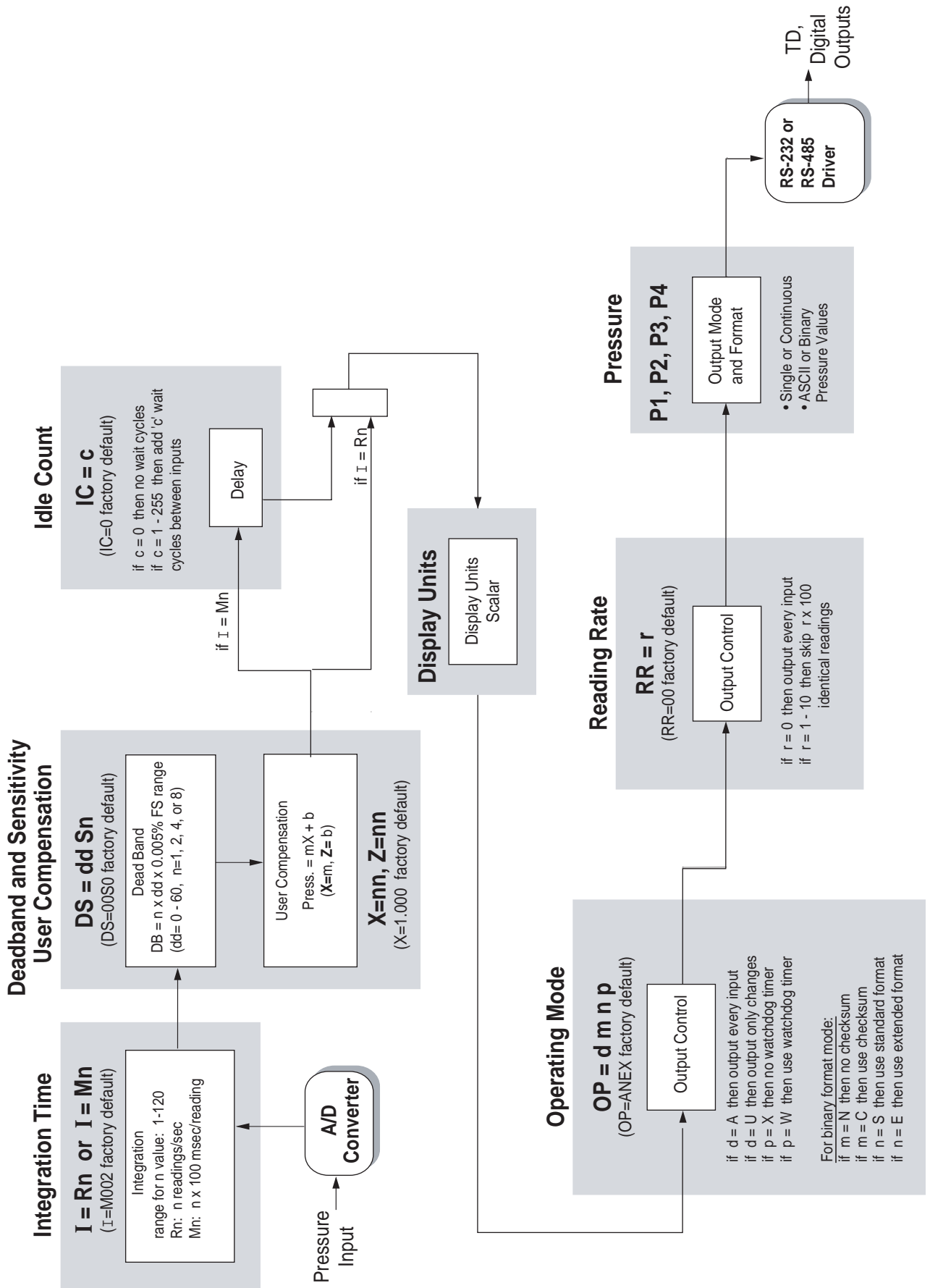

Figure 4.2—Pressure Reading Control

Shaded blocks represent command codes executed in the microprocessor

4.4 CUSTOMIZED PRESSURE RANGE

The user can adjust the pressure vs. output value transfer curve using the X=, Z= and F= commands. The X= command adjusts the slope of the pressure output curve. The Z= command adjusts the offset of the pressure output curve. The range of adjustment for X= and Z= commands is ±0.6%FS in 0.005% increments. The F= command can change the full scale pressure span to any value between 50% and 100% of the factory specified range (M=).

The purpose of these commands is to allow the user to provide compensation for the pressure values specific to an application. This type of adjustment is made after the HPB temperature compensates the pressure reading according to the factory calibration. The user-supplied values (X=, Z=) are used as an mx+b correction. The X= command supplies the slope adjustment, or 'm', value and the Z= command supplies the offset adjustment, or 'b', value. Figures 4.3 and 4.4 illustrate these commands.

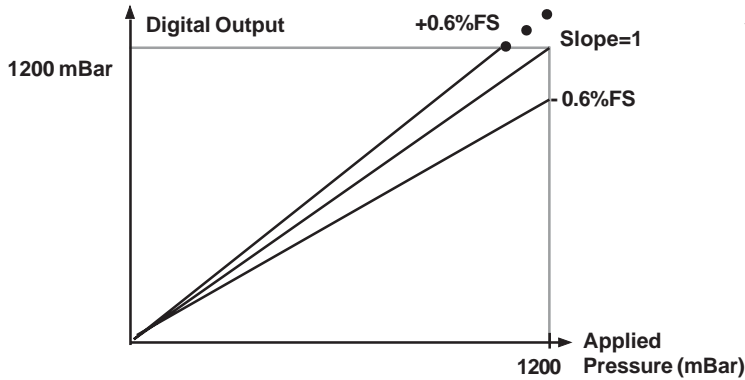

Figure 4.3—Custom Slope (X=) Options

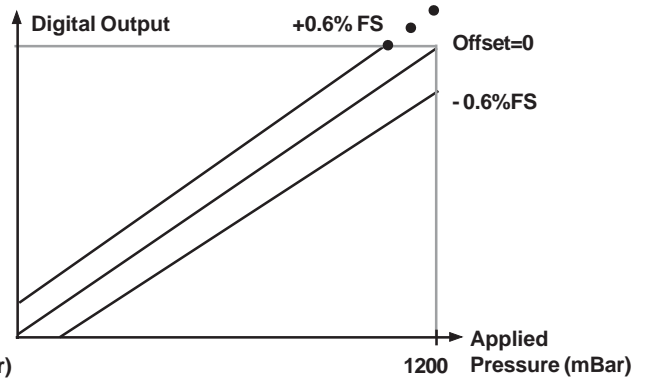

Figure 4.4—Custom Offset (Z=) Options

The user compensated pressure output can be expressed in terms of X= slope values 'm' where m=0 to ±120. The offset value, Z=, can be expressed as 'b' where b=0 to ±120.

$$\text{Pressure Output} = [(1 + m \times 0.00005) \times \text{Pressure Reading}] + [(b \times 0.00005) \times (\text{full scale})]$$

The F= command is used in conjunction with the X= and Z= command to customize the full scale range and user compensation of the HPB. The F= command allows the user to reduce the full scale range of the HPB as much as one-half the factory FS value. The F= command value can have up to 5 significant digits with a decimal point. Enter an F=0 command to disable this function and return to the factory default (M=) full scale value. Using the F= command, the maximum allowable full scale pressure is the M= value and the minimum allowable FS pressure is (0.5 x the M= value). The new F= value becomes the standard FS number used for other commands and range calculations. (Note that the accuracy specification is always referenced to the factory (M=) full scale value.) For example, to customize the full scale range of a 1200 mBar (900mm Mercury - mmhg) device to 800 mmhg, first select the desired display units using the DU command. Enter the command *ddWE followed by a *ddDU=mmhg. Then enter a *ddWE followed by a *ddF=800. The full scale pressure for this unit is now 800 mmhg.

4.5 COMMAND ILLUSTRATIONS

The figures below illustrate the commands that affect the pressure output rate. Figure 4.5 shows a varying pressure signal having a reading integration time of 200 msec. If the small variations on the pressure signal are considered noise and are undesirable, increase the integration time to time-average the pressure signal, and filter out the noise.

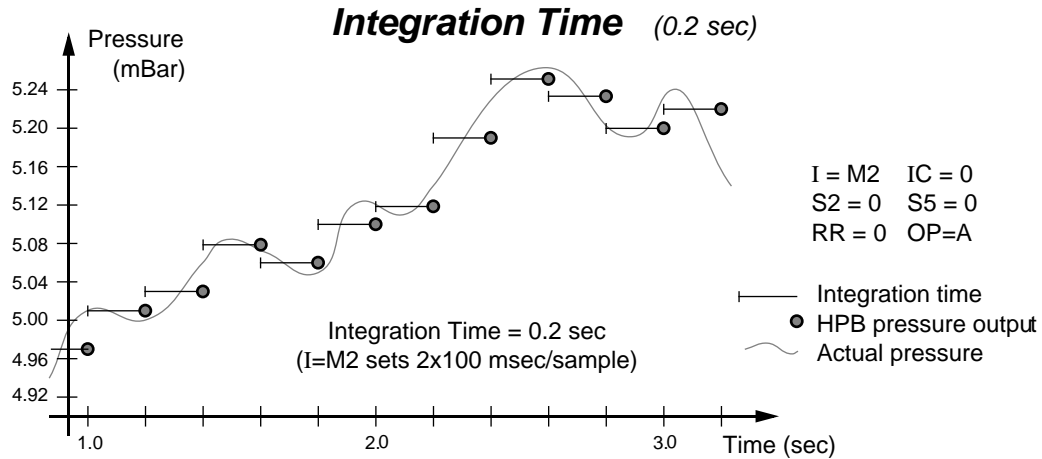

Figure 4.5—Integration (I=) Command, Example 1

Figure 4.6 shows the same pressure signal with a 1 second integration time reducing the noise variations on the output readings. Of course, the penalty for doing this is reducing the response time to rapidly changing pressures that are not considered noise.

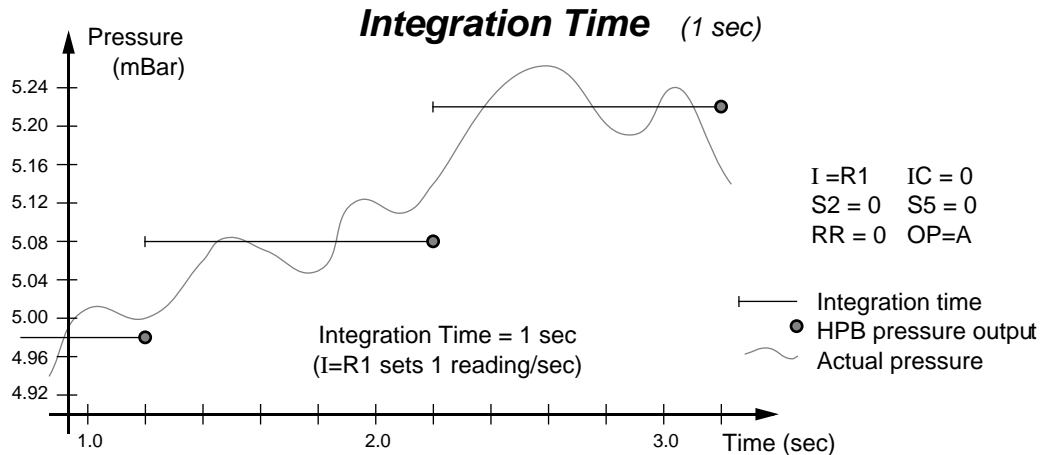

Figure 4.6—Integration (I=) Command, Example 2

Figures 4.7 and 4.8 illustrate rapid pressure changes using the **S2** and **S5** commands. The Speed Shift commands (**S2**, **S5**) allow the tracking of rapid changes while sampling less often when pressures are slowly changing. A threshold is set independently for the **S2** and **S5** commands that tell the HPB when to begin outputting samples at the higher rate. The **S2** command causes the output rate to double. The **S5** command causes the readings to be output at 50 msec intervals synchronous with the normal reading rates.

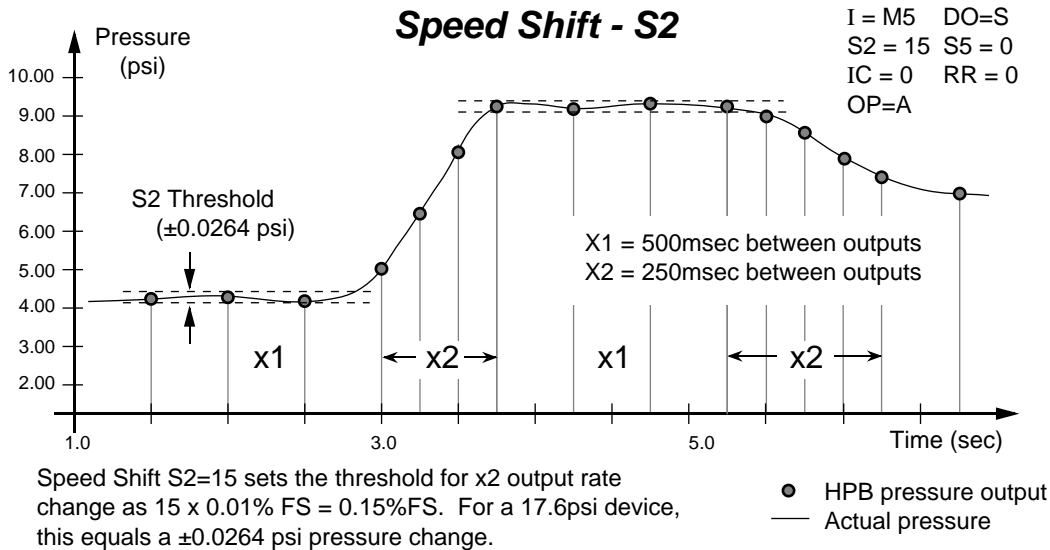

Figure 4.7—S2 Speed Shift Command Example

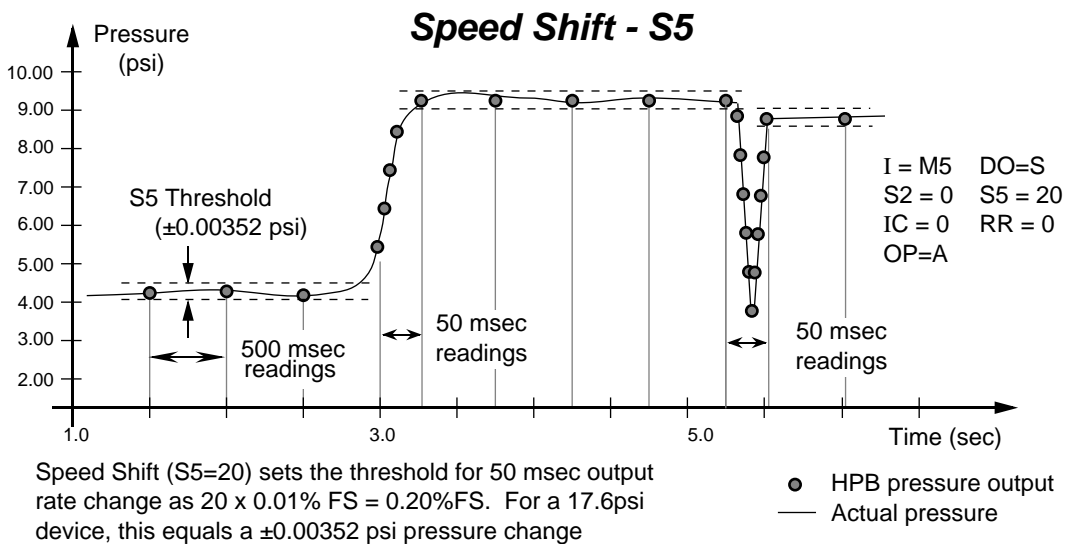

Figure 4.8—S5 Speed Shift Command Example

Figure 4.9 shows the effect of the deadband setting in the **DS** command. If a deadband of $\pm 0.02\%$ FS is selected, then the pressure output will not change reading as long as it is within this limit (± 0.00352 psi for a 17.6 psi unit). If the pressure exceeds or falls below this threshold, the pressure reading will track the actual pressure value. It will continue to track the pressure value until there is no change again within the threshold limit.

Figure 4.10 illustrates the effect of the Idle Count (**IC**) command for four different pressure curves. The **IC** command does nothing more than skip over a set number of readings. If the idle count were set to **IC=4**, then after a pressure output reading, the HPB would not output the next 4 readings and the fifth one would become the next output reading. This feature allows the reading rate to be established different from the integration time. This feature is useful for minimizing the communications traffic on a network of many HPB units.

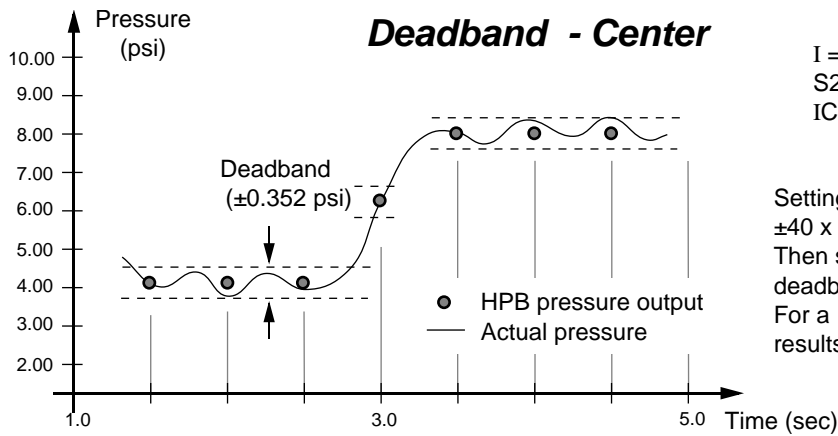

Figure 4.9a—Deadband and Sensitivity (DS) Command Examples

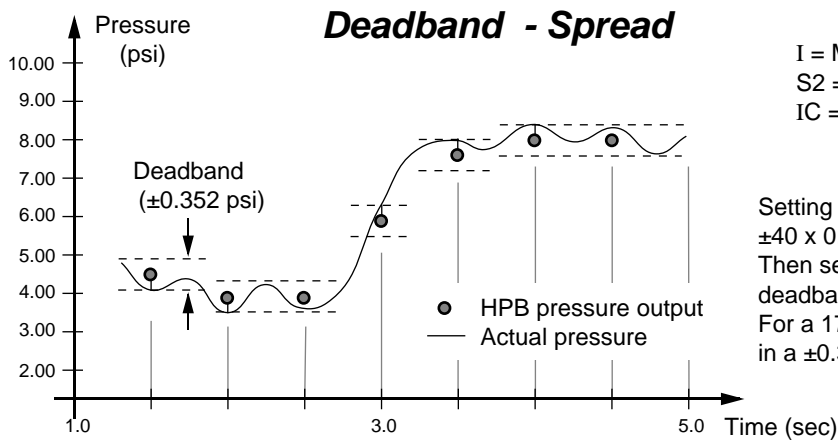

Figure 4.9b—Deadband and Sensitivity (DS) Command Examples

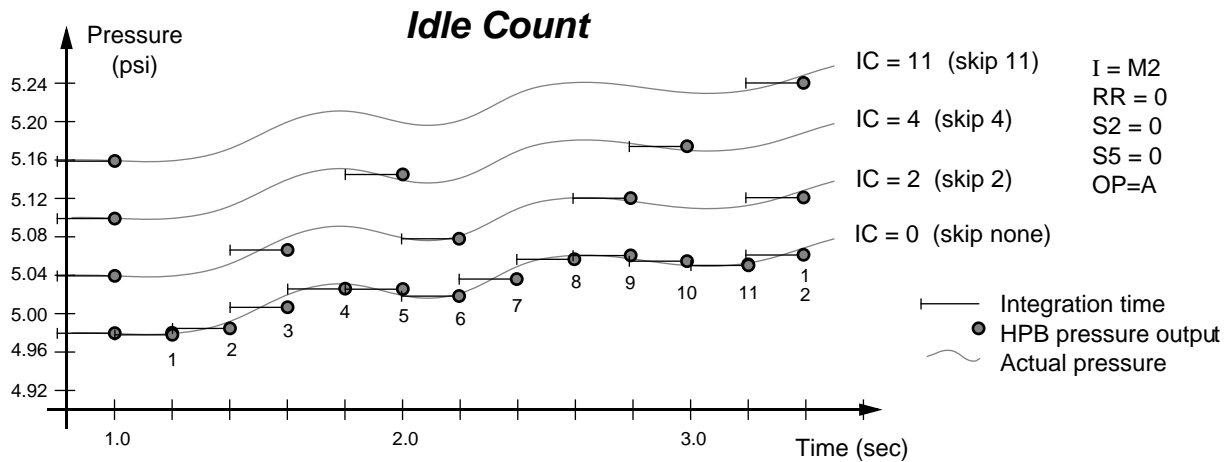
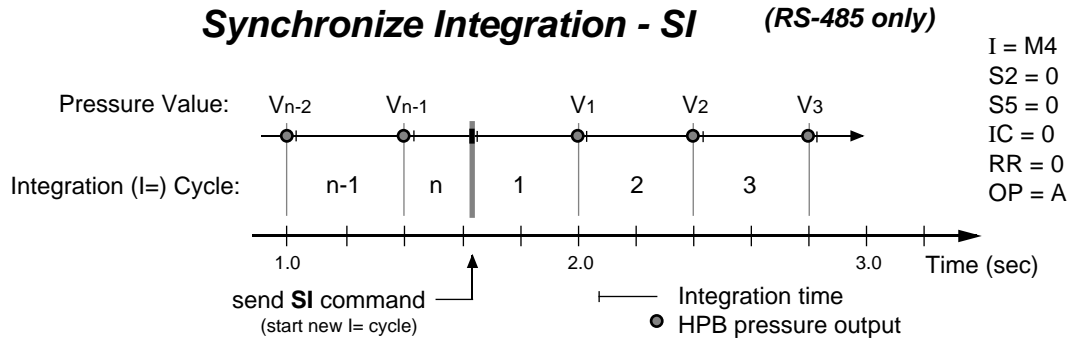

Figure 4.10—Idle Count (IC) Command Example

Figure 4.11 illustrates the Synchronize Integration cycle (SI) command as well as the Transceiver Operating parameters (TO) options that affect it. This is for RS-485 units only.



	*ddP1 Pressure Value Output during:				
TO Option	Cycle n-1	Cycle n	Cycle 1	Cycle 2	Cycle 3
TO=C (default)	Vn-2	Vn-1	Vn-1	V1	V2
TO=A	Vn-2	Vn-1	Vn-1	V1	V2
TO=S	Vn-2	Vn-1	<cr>	V1	V2
TO=H	Vn-2	Vn-1	<cr>	V1*	

* V1 can be read once anytime after Cycle 1

Figure 4.11—Synchronize Integration Cycles (SI) Command Example

4.6 PRESSURE READING DECIMAL POSITION

Digital pressure readings are displayed with a sign and a decimal position. Table 4.1 shows the number of decimal place variations among the HPB pressure ranges; the number of digits to the right of the decimal place. This is important when converting a binary format number so that decimal position can be determined. For pressure values less than 1.0, (.XXXX), the first character of the pressure reading will be a zero (=0.XXXX). For pressure values greater than 1.0, (XX.XX), the first character will be a space or a number (= XX.XX or =XX.XX). For example, a 17.6 psia device set to KGCM units (17.6psi x 0.070307= 1.23740 kg/cm²) will read the full scale pressure as “#23CP=1.2374” kg/cm². (The numerical limit for FS reading is 90,000.)

Units	Decimal Place	Units	Decimal Place
ATM	4	KPA	2
BAR	4	MBAR	1
CMWC	2	MMHG	1
FTWC	2	MPA	5
INHG	2	MWC	3
INWC	2	PFS	3
KGCM	4	PSI	3

Table 4.1—Decimal Place Locations for Pressure Readings
(Extended format selected, OP=E)

4.7 HPB ADDRESSING

The HPB provides three levels of addressing. The lowest level of address is the individual unit address, or **device ID**. This address level is used to address any single HPB. The next level is **group** address, which is separate from the device ID. All HPB units with the same group address will respond to a command sent to this level address. The last is a **global address**, which is read by all HPB's on the network. The device ID can be assigned by direct command or assigned automatically based on its position from the host processor in HPB network. The **null address** (00) is simply a default device ID that the HPB automatically assumes until one is assigned. That is, upon power-up, if there is no ID assigned, and an ID has not been stored in the EEPROM, then the HPB will assign itself the "00" null address.

The individual unit address, or **device ID**, has an assigned range from 01-89. The null address 00 is the factory default address for unassigned HPB's. A unit with the null address, replies with a 'null address' header. The null address header characters are '?' for ASCII format or '^, &, |, or %' for binary format (see Section 5.5 for these format types). A unique device ID allows the host processor to send commands to specific units on a bus.

The second level of addressing is a multicast, or **group**, address in the range of 90-98. Each unit can be assigned a group address by the ID command. A unit responds to its group address in the same manner as it does to its global address described below. The group addressing allows the host processor to send commands to several units having the same group address. The factory default group address is 90.

The highest level of addressing is the broadcast, or **global**, address 99. All units receive global addressed commands. All ring networked units respond to global commands. Only multi-drop units with assigned addresses will respond to global commands. A multi-drop unit with a null address will not reply to any global command. The global address is not assigned but is built into the HPB.

RS-232 Ring Network

The RS-232 network consists of a three-wire bus (TD, RD, and GD) that begins and ends at the host processor. The RS-232 electrical standard requires that the distance *between* units not exceed 60 feet (18 meters). An advantage of the RS-232 network is that it interfaces directly to the serial COM port of most personal computers. The maximum number of HPBs with assigned device IDs on a network is 89.

An HPB ring network connection of six units is shown in Figure 4.12. In this example, the Device IDs are sequential, starting from 01, from the transmit port of the host processor around the loop. There are two address groups, 91 and 93; each have 3 HPB units assigned.

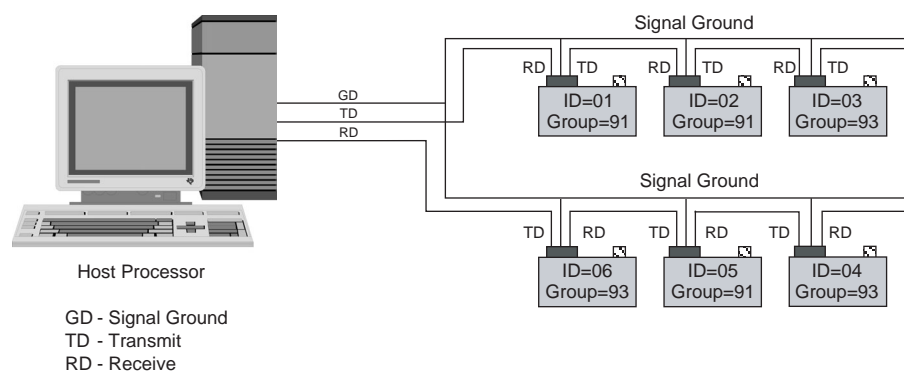

Figure 4.12—HPB RS-232 Ring Network

Each HPB on a communication ring must have a unique address in order to *individually* receive commands from the host processor. For example, if more than one HPB on a ring has a null address, and a 00 address command is transmitted by the host, only the first null address HPB will receive the command and the command is not passed on. This is the same for any address on a ring network.

Another advantage of the ring network is the ability to automatically assign device IDs to every HPB on the network. Since commands flow through every HPB on the ring, a single ***99ID=01** command will assign ID=01 to the first unit, and each HPB in the ring will assign itself the next number. As the command is passed along, each unit adds one to the ID command. For the example shown in Figure 4.12, the command will read ***99ID=07** when it returns to the host processor. The form of self-addressing will indicate the HPB position in the communication ring relative to the host processor.

Every unit in the ring network has an assigned group address. When the host processor sends a group addressed (***90** to ***98**) command, that command cycles through every HPB and is passed to the next one in the loop. Those units having that group address read the command, then pass the command and reply to the next unit in the ring. This is called a **sequential response**. Some sequential responses pass the string of HPB replies before the group command while others pass the string of HPB replies after the group command. See Table 5.3 for specific sequential command types.

Every unit in the ring network responds to a global addressed (***99**) command. All units read the command and pass the command and their response to the next unit in the ring. The sequential response is the same as for the group command described above. See Table 5.3 for sequential command types.

RS-485 Multidrop Network

The RS-485 network consists of a two-wire bus (A and B) that begins at the host processor and ends at the far end from the processor. A star network configuration can also be used where each unit is connected directly to the A and B terminals at the host processor. An advantage of the RS-485 network is that it can extend up to 4,000 feet (1,220 meters) and units can be added and removed without breaking the network connection. A requirement of the RS-485 electrical standard is that the bus is terminated at both ends by a 120 ohm resistor. Also, the standard allows a maximum of 32 units on a single two-wire bus. To accommodate more than this, some of the 32 units can be repeaters. Each repeater can add an additional 32 units. The maximum number of addressable HPBs on a network is 89.

An HPB multidrop network connection of six units is shown in Figure 4.13. In this network, the device IDs are not in order from one end of the network to the other. Looking at all the units on the bus, the device IDs are sequential beginning with ID=01 and without duplication. This is an important setup condition if global commands (*99) are desired.

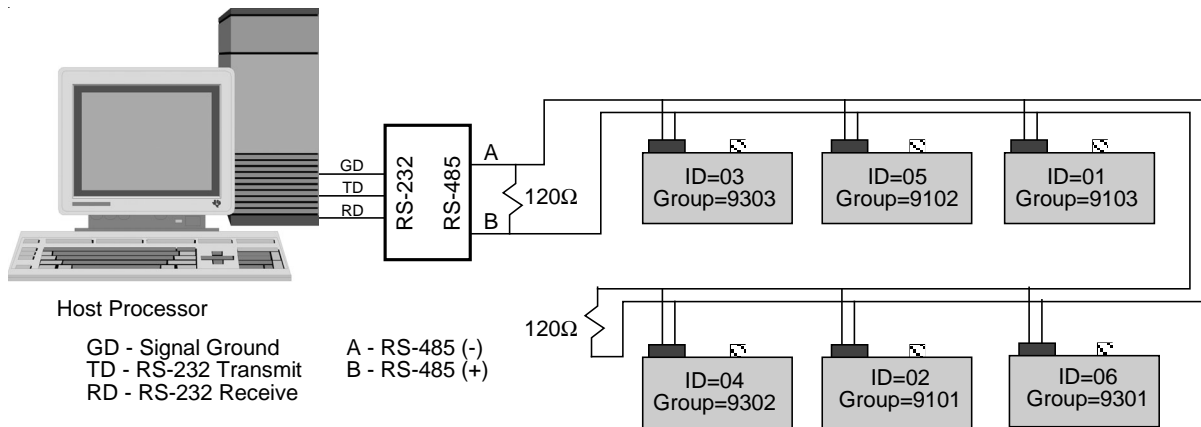

Figure 4.13—HPB RS-485 Multidrop Network

This gives the units on a multidrop bus a preassigned order to follow when they are responding to a global (*99) command. Each HPB on the communication bus must have a unique address in order to individually receive commands from the host processor.

When an RS485 unit has a null address (unassigned), it will only respond to null addressed (*00) commands. The command response will begin with the “?00” reply header. If two or more null addressed HPBs on a multidrop network receive a null addressed command, they will all respond together and cause a garbled message. Although all null addressed units will listen to group or globally addressed commands, and take the appropriate action, they will not send a response to a group or globally addressed command. It is important to assign each unit a unique and sequential device ID to begin any useful communication.”

Assign Device IDs: Start with a list of all the units serial numbers. For example, send the global commands *99WE and *99S=00001234. This will prepare the HPB with serial #00001234 to assign itself the number from the next global ID command. Send *99WE, *99ID=02, *02WE, and *02SP=ALL to complete the device ID assignment. Repeat this for each unit on the RS-485 network. Other methods for device ID assignments are described in the **ID** command description.

Assign Group Numbers: Once the device IDs are set the group IDs can be assigned. Each unit in the same group must have a sequential sub-address - beginning with 01. The sub-address tells each unit what order it should respond in a group addressed command. To set the group (91) and sub-address (01) for device ID=02, send the following commands: *02WE, *02ID=9101, *02WE, *02SP=ALL. Now when a command is sent to group 91, device ID=02 will be the first one to reply. In Figure 4.13, there are two address groups, 91 and 93; each have 3 HPB units assigned.

Every HPB in the network receives all commands. If the command has a group or global address requiring a response, the HPBs addressed will wait until the unit with the next lower address responds before sending its response. If the command had a global address (*99), then the HPBs will respond in the order of the assigned device IDs. If the command had a group address (*90 to *98), then the HPBs will respond in the order of the assigned group sub-address. If a number in the sequence of device IDs or group sub-addresses is missing, then the responses will stop and the command will be finished (see **ID** command).

When an RS-485 multidrop network has all device IDs properly assigned (Figure 4.13), then global addressed commands can seek replies from all units without conflict. The **TO=N** and **TO=P** commands instruct the units how to reply in this situation. When **TO=N** command is set, each HPB will respond in sequence beginning with ID=01, one right after another. It is important that during this response sequence the host processor, or user, not transmit on the bus until the last unit has finished its message. A carriage return (<cr>) sent during the response sequence will cause the next unit ID to send its response even though the previous unit ID is still transmitting.

If the **TO=P** command is set, then a <cr> prompt from the host processor is required for the first response and each successive response.. The ID=02 response will not transmit until 1) the previous unit's message has finished and 2) an additional <cr> has been sent on the bus. This <cr> can be sent manually by the user or systematically by the host processor. Each additional unit on the bus will require the above two conditions be completed before sending its message.

Another option in the RS-485 multidrop network is the use of alternate headers. That is, the leading symbol (*, #, etc.) in command and response communications on the bus. The **M=ALT** command is used to select the alternate message headers of non-printing characters. This option is useful when there is a conflict between the standard HPB message headers and the message characters used by some other components that share the RS-485 bus.

5 COMMANDS

5.1 COMMAND FORMAT

Communication between the host or control processor and an HPB is accomplished by message transfers, or commands and replies. Communications initiated by the host processor to one or more HPBs are called **commands** and must begin with an '*' **header character**. All commands must be terminated by a <cr> (carriage return or ENTER key). Communications initiated by an HPB to the host are called **responses** or **replies**, and begin with one of ten unique header characters (2 for ASCII, 8 for binary).

Commands may either *request information* from one or more HPBs such as read pressure, or *direct action* to one or more HPBs such as change a configuration value or operating mode.

Typical HPB command format: *ddcc = nnn <cr>

Where: * is the command header character
dd is the decimal address of the command message (00-99)
cc is the command code. The command code characters can be one letter, two letters, or a letter and a number. The letters are not case sensitive; i.e., either an upper case or lower case may be used. The HPB will convert the character to upper case.
= equal sign (required in some commands)
nnn additional characters (required in some commands)
<cr> carriage return (do not type, press the ENTER key)

Note: For RS-485 mode, alternate headers are available. (see **M=** command)

For RS-232 mode, when manually applying commands to one or more HPBs which are in the continuous send mode (**P2, P4, T2, T4**), the special header character '\$' should be used to suspend all HPB transmissions while the command message is being typed. The '\$' is immediately followed by the normal command format.

Also for RS-232 mode, if an erroneous command is sent to the HPB, it is echoed back to the host in the same form it was sent. The only exception to this is when a group or global address command (ID = 90 to 99) is sent such as *99S2=15<cr>. These addresses will always echo the command back to the host processor after being read by all HPBs.

Commands are not executed until the carriage return is applied; therefore, any command message may be reentered at any time prior to the carriage return. To do this, type an '*' followed by the command, or press a carriage return and retype the command.

Only the minimum number of characters is required for command inputs to distinguish between various command options. For example, **DU=MB, DU=MBAR, or DU=MBXYZ** will all set the display units to millibar, since only the first two characters (MB) are needed. Also, when a parameter value is entered that exceeds the stated range for that value, the parameter will be set to the maximum value for that range.

5.2 INFORMATION REQUEST COMMANDS

Information request commands retrieve information from the HPB as an inquiry. One example would be a speed shift command inquiry. The command *00S2 would request the x2 speed shift threshold value. The response may be ?01S2=12, assuming the unit had not been assigned a device ID. A characteristic of the information request command is that the '=nnn' portion of the command format is dropped.

Most commands that set parameters may be used in this form to inquire about that parameter's value. For commands that have a single letter command code (**cc**), use that letter followed by an '=' equal sign to form an inquiry.

5.3 ACTION DIRECTING COMMANDS

Action directing commands can 1) change the HPB configuration, 2) set specific parameter values, 3) activate or deactivate controls, or 4) store information in EEPROM.

Examples of action directing commands are:

- 1) *00MO=P2M2 Continuous pressure readings and user message at power-up
- 2) *00IC=9 Set the idle count value to 9
- 3) *00TC=ON Turn on the tare control switch
- 4) *00B=02-12-02 Set B string in EEPROM to "02-12-02"

A characteristic of most action directing commands is that they are preceded by a RAM, or EEPROM, write enable (**WE**) command. This signals the HPB to write the action directing parameter(s) and is provided as a safeguard to prevent inadvertent changes. The only exception to this is the initialization (**IN**) command which is activated upon receipt.

5.4 COMMAND REPLIES – GENERAL

Replies are transmitted from the HPB in response to an information request inquiry or due to a power applied condition. All replies end with a <cr> (carriage return character), which can be used as a delimiter, to distinguish between sequential responses. Replies have two forms:

ASCII format – which consists of standard keyboard alphanumeric characters (see Section 5.5)

binary format – which require fewer data bytes that are encoded for computer translation (see Section 5.6).

The binary format replies are for pressure readings using the **P3** and **P4** commands. The replies are more compact, require less data transmission, and more than double the RS-232, or RS-485, data transfer capacity. However, the binary format is difficult for people to translate and is best left for a computer to interpret.

The ASCII format characters have readable output values and do not require user interpretation. However, the binary format will transmit a pressure reading in 6 bytes where it may take up to 16 bytes in the ASCII format. (See the Binary Format Replies description in section 5.5 for a detailed explanation of the address and pressure encoding.) There is a mode (**OP=R**) that can transmit ASCII format in 8 bytes.

When an information request command is sent to an HPB or group of HPBs the reply will take on different forms based on the state of the HPB, the address of the HPB, or the out-of-range condition for that parameter.

A pressure-over-range error condition will occur when the applied pressure is greater than or equal to 1% of full scale (FS) above the FS limit. For example, if the pressure applied to a 17.6 psi unit is 17.776 psi, then an over range error condition is set (see **RS** command). Similarly, an under-range condition occurs when the applied pressure is greater than or equal to 1%FS below the minimum limit. To indicate an out-of-range condition (greater than ±1% FS), the equal '=' sign will be replaced by an exclamation point '!' in the pressure reading reply. This indicator will disappear when the applied pressure is in range, but the **RS** command error flag will continue to be set until it is cleared by an inquiry.

The maximum reading will flatten out between 1% and 5% beyond the FS limit with increasing pressure. This limit varies from device to device but will continue to display the out-of-range indicator ("!" in place of "=") until the pressure drops below 1% over FS limit.

5.5 ASCII FORMAT REPLIES

Most commands use the ASCII format reply and may be identified by the header character (ASCII – American Standard for Coded Information Interchange). The ASCII format consists of standard keyboard alphanumeric characters and symbols. The **header character** is the first character in the reply from the HPB. The ASCII format information request reply uses the following header characters:

#	ASCII format reply from an assigned address HPB.
?	ASCII format reply from a null address HPB.

Example replies to command code (cc) are: (where xx = the parameter value)

#ddcc=xx	reply from unit with an assigned address (dd).
#ddcc!xx	reply from unit with an assigned address (dd) when 1) pressure or temperature reading is out-of-range (over/under limit = $\pm 1\%$ FS) or, 2) an EEPROM parity error has occurred (pressure reading will output zero).
#ddcc=..	reply from unit with an assigned address (dd) when data is not available yet from the HPB. Request again.
?ddcc=xx	reply from a null address unit (dd).
?ddcc!xx	reply from a null address unit (dd) when 1) pressure or temperature reading is out-of-range (over/under limit = $\pm 1\%$ FS) or, 2) an EEPROM parity error has occurred (pressure reading will output zero).
?ddcc=..	reply from a null address unit (dd) when data is not available yet from the HPB. Request again.

Note: For multidrop bus mode alternate header descriptions see **MO** command description.

ASCII format command and reply messages contain only the set of printable ASCII characters as described in the following list of legal characters:

*	Asterisk
-	Minus
+	Plus
.	Period
=	Equal
>	Greater than
<	Less than
0-9	Numbers zero through nine
a-z	Letters 'a' through 'z' (not sent in replies)
A-Z	Letters 'A' through 'Z'
#	Pound sign
?	Question mark
{	Left brace
!	Exclamation mark
^	Circumflex
	Bar
}	Right brace
@	At/each
&	And/ampersand
%	Percent
\$	Dollar sign (used before a command to stop, or suspend, continuous HPB transmissions while manually typing commands)
‘ ‘	Space, or Blank

5.6 BINARY FORMAT REPLIES

The binary format reply is only used for the pressure reading commands **P3** and **P4**. It consists of a 1 byte header character, 4 bytes of data, an optional 1-byte cyclic check sum, and a 1-byte <cr> character. For the binary format replies, the address type, error condition and data sign are encoded into the single header character as shown in Table 5.1 below.

Header Characters	Assigned Address	Error Condition	Data Sign Hdr.	Alternate RS-485 only (1)
{	Yes	No	+	DC1 (ctrl Q)
}	Yes	No	-	DC2 (ctrl R)
!	Yes	Yes	+	DC3 (ctrl S)
@	Yes	Yes	-	DC4 (ctrl T)
^	Null	No	+	none
&	Null	No	-	none
	Null	Yes	+	none
%	Null	Yes	-	none

(1) See **M=** command and Table 5.2 for ASCII hex value

Table 5.1—Header Description for Binary Format Pressure Readings

Binary Format Character	Decimal Value	Hex Value	Binary Value		Least 6 Significant Bits
@	64	40	0100	0000	000000
A	65	41	0100	0001	000001
B	66	42	0100	0010	000010
C	67	43	0100	0011	000011
D	68	44	0100	0100	000100
E	69	45	0100	0101	000101
F	70	46	0100	0110	000110
G	71	47	0100	0111	000111
H	72	48	0100	1000	001000
I	73	49	0100	1001	001001
J	74	4A	0100	1010	001010
K	75	4B	0100	1011	001011
L	76	4C	0100	1100	001100
M	77	4D	0100	1101	001101
N	78	4E	0100	1110	001110
O	79	4F	0100	1111	001111
P	80	50	0101	0000	010000
Q	81	51	0101	0001	010001
R	82	52	0101	0010	010010
S	83	53	0101	0011	010011
T	84	54	0101	0100	010100
U	85	55	0101	0101	010101
V	86	56	0101	0110	010110
W	87	57	0101	0111	010111
X	88	58	0101	1000	011000
Y	89	59	0101	1001	011001
Z	90	5A	0101	1010	011010
[91	5B	0101	1011	011011
\	92	5C	0101	1100	011100
]	93	5D	0101	1101	011101
^	94	5E	0101	1110	011110
_	95	5F	0101	1111	011111

Binary Format Character	Decimal Value	Hex Value	Binary Value		Least 6 Significant Bits
` (1)	96	60	0110	0000	100000
!	33	21	0010	0001	100001
"	34	22	0010	0010	100010
#	35	23	0010	0011	100011
\$	36	24	0010	0100	100100
%	37	25	0010	0101	100101
&	38	26	0010	0110	100110
'	39	27	0010	0111	100111
(40	28	0010	1000	101000
)	41	29	0010	1001	101001
j (2)	106	6A	0110	1010	101010
+	43	2B	0010	1011	101011
,	44	2C	0010	1100	101100
-	45	2D	0010	1101	101101
.	46	2E	0010	1110	101110
/	47	2F	0010	1111	101111
0	48	30	0011	0000	110000
1	49	31	0011	0001	110001
2	50	32	0011	0010	110010
3	51	33	0011	0011	110011
4	52	34	0011	0100	110100
5	53	35	0011	0101	110101
6	54	36	0011	0110	110110
7	55	37	0011	0111	110111
8	56	38	0011	1000	111000
9	57	39	0011	1001	111001
:	58	3A	0011	1010	111010
:	59	3B	0011	1011	111011
<	60	3C	0011	1100	111100
=	61	3D	0011	1101	111101
>	62	3E	0011	1110	111110
?	63	3F	0011	1111	111111

(1) The grave accent character is used instead of a space to provide printable characters for debug and verification purposes.

(2) The lower case 'j' is used instead of the '*' because the '*' is interpreted as a message header character.

Table 5.2—Binary Format Character Codes

Example **P3, P4** command replies in binary format: (where hhhh = the 4 byte data value)

- { hhhh<cr> reply from unit with an assigned address, no errors, (+) data sign.
- @ hhhh<cr> reply from unit with an assigned address, error condition exists, (-) data.
- ^ hhhh<cr> reply from a null address unit, no errors, (+) data sign.
- & hhhh<cr> reply from a null address unit, no errors, (-) data sign.
- { nnnn<cr> where nnnn pressure value is (FFFF)Hex, all ones.

The binary format reply: xx??? or xx_?? indicates that data is not yet available from the HPB. The ‘xx’ is the header character and the 6 most significant bits of the address.

The 4 byte data value hhhh contains the device address and the pressure reading. The most significant bit of each ‘h’ character is a parity bit. The next most significant bit of each ‘h’ character is either a 1 or 0 required to make the resultant byte a printable character. The 6 least significant bits are used for the device address and pressure reading.

The device ID and the pressure reading can be read by combining the 6 least significant bits of each of the four ‘h’ characters, which result in 24 bits of information. The first 7 bits represent the device address in binary form (00 through 89 decimal). The next 17 bits represent the pressure reading and can be configured in the signed form or the extended form by using the OP command. The 24 bit binary forms are:

- Extended:* 7 bit binary device address 17 bit binary pressure data
- Signed:* 7 bit binary device address sign bit + 16 bit binary pressure data

Example binary reply: { @#16<cr>

Refer to Table 5.1 for the header character ‘{’ definition. The sign of this pressure value is determined by the header character. The next 4 characters, ‘@#16’, contain the encoded device address and the temperature compensated pressure reading. For this example, the extended form is used so that the pressure data is represented as a 17 bit binary value. Using the binary format character codes found in Table 5.2, convert each of the 4 byte characters into the binary value equivalent. The highlighted portion of each character below represents the 6 least significant bits. (Parity is off, OP=N)

@=01 **000000** #=00 **100011** 1=00 **110001** 6=00 **110110**

Using the least significant (LS) 6 bits of each of the 4 data bytes, regroup the binary numbers into the 7 bit binary device address and 17 bit binary pressure data, which produces the 24 bit string:

000000 100011 110001 110110 = @#16 least significant 6 bits of each byte

0000001 00011110001110110 = (device ID=01) and (pressure = 15,478)

The binary format reply indicates the device address is **ID=01** and the pressure reading is 15,478. Now, the decimal point position for the pressure reading must be determined. The decimal place is in the same position as when it reads a P1 pressure command (see Table 4.2). So, if this is a 17.6psia device reading in inches water column (DU=INWC) then there are 2 decimal places. The final reading from the binary format will be **154.78 inH₂O**. The header character for this binary reply was ‘{’ which indicates a positive pressure value.

5.7 COMMAND AND REPLY SEQUENCING

When the HPB is operated in the digital output mode, it may be connected to a host processor or computer via an RS-232 or RS-485 connection. See Section 6 for various electrical connections. In this mode, the host processor sends a command and the HPB responds with a reply. The reply and timing of the reply are dependent on the command and HPB network configuration.

Typical command and reply messages are shown in Figure 5.1 for a single HPB connected to a host processor. The **CMD** waveform represents the command sent from the host to the HPB. It is actually a sequence of RS-232 level ASCII characters sent at the correct baud rate and parity type (see **BP** command). The **REPLY** is the corresponding response from the HPB to the **CMD** command. Note that the command input is case insensitive, that is, either upper case or lower case letters may be used. For global and group commands, the HPB reply is always in upper case letters. The reply format is ASCII and the device is initially unassigned, or null address.

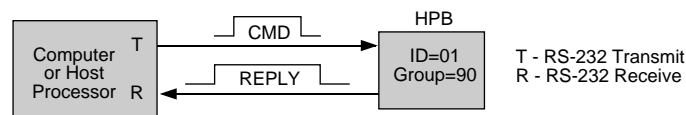

COMMAND	REPLY	COMMENT
Power-on	?01HPA____17.6_psia	factory-set power-on message
*01S=	?01S=00036714	Read factory-set serial number
*99we	*99WE	RAM or EEPROM write enable (global)
*99id=01	*99ID=02	Set device IDs (global)
*01P1	#01CP=12.345	Read pressure from device ID=01
*01ID	#01ID=90	Read group number

Figure 5.1—Single HPB Command and Reply

When several HPB units are serially connected as a network, the reply sequence now depends on the type of address (individual, group, or global) and command type (sequential response or not). Refer to Table 5.3—Command List Table, for the sequential response type of each command.

Different types of command and reply messages are shown in Figure 5.2 for a three-HPB network connected to a host processor. The commands are sent to individual units, groups and global addresses. Note that for group and global addressed commands, the command is sent around the network and returns to the host processor. If the host processor sends a sequential response command to a group or global address, then the reply(ies) may return before or after the command, depending on the command type. Examples of the different types of sequential response commands are also shown. The reply format is ASCII.

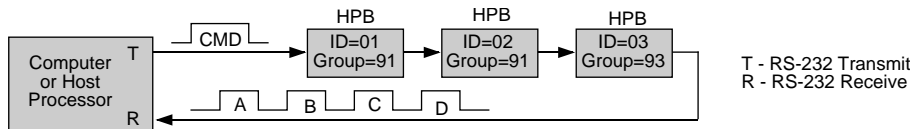

Command (1)	Reply A	Reply B	Reply C	Reply D
*01T1	#01CT=25.4	-	-	-
*02WE	-	-	-	-
*02DU=mmhg	-	-	-	-
*02DU	#02DU=MMHG	-	-	-
*92DU	#02DU=MMHG	*92DU	-	-
*91P1	#01CP=1.024	#03CP=15.25	*91P1	-
*91CK	*91CK	#01CK=OK	#03CK=OK	-
*99we	*99WE	-	-	-
*99bp=n19200	*99BP=N19200	-	-	-
*99RS==	#01RS=0000	#02RS=010+	#03RS=000-	*99RS==
*99WE	*99WE	-	-	-
*99sp=all	*99SP=ALL	-	-	-
*99P1	#01CP=1.274	#02CP=12.498	#03CP=-.00004	*99P1

(1) See Table 5.3 for types of sequential response commands.
 - Indicates there is no reply for this timing location

Figure 5.2—Multiple HPB Network Command and Replies

5.8 COMMAND ERRORS

For RS-232 ring configuration, if the host processor receives an HPB reply with a '*' header character, this indicates one of three conditions.

1. If the reply is exactly the same as the command sent, and the command was not sent to a group or global address (90 to 99), then the command has been rejected due to an incorrect header, address number, command code or action character.

This error is common if an incorrect command code format was used or if the command should have been preceded by a write enable (WE) command and was not.

If the command was rejected because of an incorrect command code or action character, an error indicator is set which can be read and cleared with the Read Status (RS) command.

2. If the command was a group or global command, then the reply should contain the *90.. to *99.. command sent. (The command should contain a 9 as the first digit of the group or global address.) This reply indicates to the host processor the command has been delivered to all addressed units in the network. This indicates an error only if the reply does not contain the command sent.
3. The command stream has been aborted by the sending host processor.

NOTE: A Read Status command is used to determine the error condition and clear the error status. (See Read Status command description for error conditions.)

5.9 COMMAND SUMMARY TABLE

The HPB command set is summarized in Table 5.3—Command List. A more detailed description of each command can be found in Section 5.10—Command Descriptions.

Table heading explanations for Table 5.3—Command List:

- Command Code:* Two-character code (cc) in the command format. The command code characters can be one letter followed by an '=' equal sign, two letters, a letter and a number. The letters are not case sensitive; i.e. either upper case or lower case may be used. The HPB will convert the characters to upper case.
- Action Directing Command:* Does this command change the HPB configuration? **Yes**—The command changes the HPB configuration as an action directing command. **No**—The command is only an information request command.
- Sequential Response with Group or Global Address:* Commands that begin with a group or global address (ID=90-99), are passed through the HPB network from one device to the next and eventually end up back at the host processor. The HPB response is sent with the command through the network. **Before**—The HPB response is sent before the group or global command. This is a sequential response. **After**—The HPB response is sent after the group or global command. **No**—The HPB just passes the command through the network with no response.
- Input or Output:* Is information input to the HPB or output from the HPB? **In**—Command is only used to input (action direct command) to the HPB. **Out**—Command is only used to output (request information inquiry) from the HPB. **Both**—Command can be used for either IN or OUT purposes.
- Requires Write Enable:* Is a WE command required before for this command? **Yes**—When sent as an action directed command, it must be preceded by a WE command. **No**—Never requires a WE command beforehand. These are request information commands only.
- Terminates Continuous Commands:* Will this command stop the HPB flow? **Yes**—This command will end the continuous flow of the P2, P4, T2, T4 commands. **No**—Command will not stop the continuous flow commands.
- Write to EEPROM:* Can this command have parameters stored in EEPROM? **Yes**—Parameter values associated with this command may be stored in EEPROM. **No**—Can not store anything from this command in EEPROM. **All**—Cause all parameters to be store in EEPROM.

Command Code	Action Directing Command	Sequential Response with (90-99) Addresses	Input or Output Type	Requires Write Enable	Terminates Continuous Commands	Can Write to EEPROM	Can Write to DAC	Command Description
A=	No	After (4)	Both	Yes	No	Yes (8)	No	Data string A – up to 8 characters
B=	No	After (4)	Both	Yes	No	Yes (8)	No	Data string B – up to 8 characters
BP	Yes	No	In	Yes	Yes	No (9)	No	Set baud rate and parity
C=	No (1)	After (4)	Both	Yes	No	Yes (8)	No	Data string C – up to 8 characters
CK	No	After (4)	Out	No	No	No	No	Check for EEPROM checksum error
D=	No (1)	After (4)	Both	Yes	No	Yes (8)	No	Data string D – up to 8 characters
DO	Yes	Before	Both	Yes (6)	No	No (9)	No	Set default operating parameters
DS	Yes	Before	Both	Yes (6)	No	No (9)	No	Set deadband and sensitivity values
DU	Yes	Before	Both	Yes (6)	No	No (9)	No	Set pressure output display units
F=	Yes	After (4)	Both	Yes (6)	No	No (9)	No	Set custom full scale pressure range
I=	Yes	After (4)	Both	Yes (6)	No	No (9)	No	Set integration time, Rn and Mn forms
IC	Yes	Before	Both	Yes (6)	No	No (9)	No	Set idle count (data output rate)
ID	Yes	Before	Both	Yes (6)	No	No (9)	No	Set HPB device ID or group number
IN	No (2)	No	In	No	Yes	No	No	Initialize or reset HPB processor
M=	Yes	After (4)	Out	No	No	No	No	Reads maximum full scale setting
MO	Yes	Before	Both	Yes (6)	No	No (9)	No	Set power-up mode parameters
OP	Yes	Before	Both	Yes (6)	No	No (9)	No	Set operating mode parameters
P=	No	After (4)	Out	No	No	No	No	Read HPB production date
P1	No	Before (5)	Out	No	No	No	No	Single pressure reading (ASCII)
P2	No (3)	After	Out	No	Yes (7)	No	No	Continuous press. reading (ASCII)
P3	No	Before (5)	Out	No	No	No	No	Single pressure reading (binary)
P4	No (3)	After	Out	No	Yes (7)	No	No	Continuous press. reading (binary)
RR	Yes	Before	Both	Yes (6)	No	No (9)	No	Set reading rate for identical data
RS	No	Before (5)	Out	No	No	No	No	Read status of error conditions
S=	No	After (4)	Out	No	No	No	No	Read HPB factory serial number
S2	Yes	Before	Both	Yes (6)	No	No (9)	No	Set 2x speed shift threshold
S5	Yes	Before	Both	Yes (6)	No	No (9)	No	Set 50msec interval threshold
SI	Yes	No	In	No	No	No	No	Synchronize Pressure Integration
SP	Yes	No	In	Yes	No	All	No	Store RAM parameters in EEPROM
T1	No	Before (5)	Out	No	No	No	No	Single temperature reading (°C)
T2	No (3)	After	Out	No	Yes (7)	No	No	Continuous temp. reading (°C)
T3	No	Before (5)	Out	No	No	No	No	Single temperature reading (°F)
T4	No (3)	After	Out	No	Yes (7)	No	No	Continuous temp. reading (°F)
TO	Yes	Before	Both	Yes (6)	No	No (9)	No	Set transceiver operating mode
U=	Yes	After (4)	Both	Yes (6)	No	No (9)	No	Set user supplied pressure units
V=	No	After (4)	Out	No	No	No	No	Read HPB software code version
WE	Yes	No	In	No	No	No	No	Write enable for RAM/EEPROM
X=	Yes	After (4)	Both	Yes (6)	No	No (9)	No	Set 'm' of user mx+b control
Z=	Yes	After (4)	Both	Yes (6)	No	No (9)	No	Set 'b' of user mx+b control

Table 5.3—Command List

*See previous page for descriptions of the table headings.
See following page for Command List Notes.*

Table 5.3—Command List Notes

- (1) The **C=** and **D=** commands do not change the mode of operation but do provide a user supplied power-up message if configured using the **MO** command.
- (2) The **IN** command does not change the operating parameters stored in RAM, but it does stop continuous readings (**P2**, **P4**, **T2**, **T4** commands). If the **IN=RESET** command is sent, then any parameters that were stored in RAM and were not stored in the EEPROM with a **SP** command, will default to the last stored EEPROM value. This may cause a change in the operational parameters as well as a configuration change.
- (3) The **P2**, **P4**, **T2**, and **T4** commands do not change the operating parameters, only activate continuous readings.
- (4) When an information request command is sent to a group or global address, the HPBs do not respond sequentially. That is, the command is returned to the host processor before the replies from the HPBs. Also, these commands require more time for execution, often requiring EEPROM reads and/or writes, so responses from more than one HPB are not received in any guaranteed order. During the execution of one of these commands, if another command is received that is an “After” type, whether globally, group, or individually addressed, the received command is rejected and the command read status error (see **RS** command) is set.
- (5) These commands may cause sequential responses from any, all or none of the addressed units. A sequential response is when the HPB reply is sent before the global or group command through the network. See the individual command descriptions for detailed information.
- (6) These commands only require a write enable (**WE**) when used in the action directing form. For these commands the **WE** command provides a single occurrence write enable for RAM update. That is, only the next instruction is written to RAM. The **WE=RAM** command provides continuous write enables for RAM for multiple command updates. The continuous RAM enable is active until a **WE** is sent.
- (7) These commands terminate an active continuous reading command (**P2**, **P4**, **T2**, **T4**) and initiate the new one.
- (8) These commands automatically write to the EEPROM when they are used in the action directing form, which must be preceded by a **WE** command.
- (9) These commands can be used to change RAM contents, which can then be written to the EEPROM using the **SP=ALL** command.

5.10 COMMAND DESCRIPTIONS

In the command descriptions, the definitions and conventions below apply. For an example of each command and associated reply, see Section 3 Commands – Quick Reference. The factory default values are shown in Table 5.4.

Inquiry: **Information requesting command**

Action: Action directing command(s)

EEPROM Store: Command(s) to permanently store value or condition into EEPROM

Bold Words that appear in boldface should be typed as shown

Italics Words that appear in italics are place holders for information you supply

{Either|Or} Words that appear in braces with a vertical line between indicate a mandatory choice between two or more items.

Typical HPB command format: *ddcc = nnn <cr>

- Where: * is the command header character
 dd is the decimal address of the command message (00-99)
 cc is the command code. The command code characters may be one letter, two letters, or a letter and a number. The letters are not case sensitive; i.e. either upper case or lower case may be used. The HPB will convert the character to upper case.
 = equal sign (required in some commands)
 nnn additional characters (required in some commands)
 <cr> carriage return (ENTER key) **must** follow every command.

Commands are not executed until the carriage return is applied; therefore, any command message may be re-entered at any time prior to the carriage return. To do this, just type an '*' followed by the remainder of the command.

Command	Factory Default		Command	Factory Default		Command	Factory Default
A=	(empty)		I=	M2		S2	0
B=	(empty)		IC	0		S5	0
BP	N(9600)		ID	90	RS-232	T=	0.0000
C=	(empty)		ID	9000	RS-485	TC	OFF
D=	(empty)		M=	(psi range)		TO	ROCN
DO	EON		MO	X2M1		TO	M1CN
DS	00S0		O=	0		U=	1.000
DU	PSI		OP	ANEX		V=	(ver.#)
F=	0		P=	(date)		W=	100
H=	100		RR	0		X=	0
			S=	(ser.#)		Z=	0

Table 5.4—Factory Default Command Responses

A= Data String A

The **A=** data string command can be used to store and retrieve up to eight characters in the EEPROM. This command must have 1 to 8 characters immediately following the '=' character. The message is terminated with the <cr> (ENTER key) character. The data string is automatically stored in EEPROM with this action command. Since this string is stored in EEPROM, it will remain in the HPB even after the power is turned off. Examples include dates for maintenance checks, over/under range pressure or temperature values, or key pressure readings specific to application. If the response has an '!' character instead of '=', there was an EEPROM parity error.

Note: This command will not work when a ***ddWE=RAM** continuous write enable is active. It must be preceded by a singular write enable (***ddWE**).

Inquiry: ***ddA=**

Action: ***ddWE**

***ddA=Your_msg**

Your_msg must have 1 to 8 characters immediately following the '=' character. The message is terminated with the <cr> character. The legal characters for *Your_msg* include all characters between the 'space' (SP) and lower case 'z' inclusive, except the '*', in standard ASCII (see last page of manual).

B= Data String B

The **B=** data string command can be used to store and retrieve up to eight characters in the EEPROM. This command must have 1 to 8 characters immediately following the '=' character. The message is terminated with the <cr> (ENTER key) character. The data string is automatically stored in EEPROM with this action command. Since this string is stored in EEPROM, it will remain in the HPB even after the power is turned off. Examples include dates for maintenance checks, over/under range pressure or temperature values, or key pressure readings specific to application. If the response has an '!' character instead of '=', there was an EEPROM parity error.

Note: This command will not work when a ***ddWE=RAM** continuous write enable is active. It must be preceded by a singular write enable (***ddWE**);

Inquiry: ***ddB=**

Action: ***ddWE**

***ddB=Your_msg**

Your_msg must have 1 to 8 characters immediately following the '=' character. The message is terminated with the <cr> character. The legal characters for *Your_msg* include all characters between the 'space' (SP) and lower case 'z' inclusive, except the '*', in standard ASCII (see last page of manual).

C= Data String C

The **C=** data string command can be used to store and retrieve up to eight characters in the EEPROM. This command must have 1 to 8 characters immediately following the '=' character. The message is terminated with the <cr> (ENTER key) character. The data string is automatically stored in EEPROM with this action command. Since this string is stored in EEPROM, it will remain in the HPB even after the power is turned off. Examples include dates for maintenance checks, over/under range pressure or temperature values, or key pressure readings specific to application. If the response has an '!' character instead of '=', there was an EEPROM parity error.

Note: This command will not work when a ***ddWE=RAM** continuous write enable is active. It must be preceded by a singular write enable (***ddWE**).

Note: This data can be used to provide the first eight characters of a user provided start-up message (see the **MO** command). When used as a start-up message, any space character in the **C=** message will terminate the message. Use an underscore (_) character for spaces.

Inquiry: *ddC=

Action: *ddWE

*ddC=*Your_msg*

Your_msg must have 1 to 8 characters immediately following the '=' character. The message is terminated with the <cr> character. The legal characters for *Your_msg* include all characters between the 'space' (SP) and lower case 'z' inclusive, except the '*', in standard ASCII (see last page of manual).

CK Check EEPROM

The **CK** EEPROM command performs a checksum on both the characterization area and the configuration area of the EEPROM. This check typically takes 180 msec.

Inquiry: *ddCK

There are four possible responses for this command.

#(or ?)ddCK=OK	Indicates no checksum errors
#(or ?)ddCK=ERR1	Indicates a characterization area checksum error
#(or ?)ddCK=ERR2	Indicates a configuration area checksum error
#(or ?)ddCK=ERR3	Indicates both checksum errors

D= Data String D

The **D=** data string command can be used to store and retrieve up to eight characters in the EEPROM. This command must have 1 to 8 characters immediately following the '=' character. The message is terminated with the <cr> (ENTER key) character. The data string is automatically stored in EEPROM with this action command. Since this string is stored in EEPROM, it will remain in the HPB even after the power is turned off. Examples include dates for maintenance checks, over/under range pressure or temperature values, or key pressure readings specific to application. If the response has an '!' character instead of '=', there was an EEPROM parity error.

Note: This command will not work when a ***ddWE=RAM** continuous write enable is active. It must be preceded by a singular write enable (***ddWE**).

Note: This data can be used to provide the last eight characters of a user provided start-up message (see the **MO** command). When used as a start-up message, any space character in the **D=** message will terminate the message. Use an underscore (_) character for spaces.

Inquiry: ***ddD=**

Action: ***ddWE**

***ddD=Your_msg**

Your_msg must have 1 to 8 characters immediately following the '=' character. The message is terminated with the <cr> character. The legal characters for *Your_msg* include all characters between the 'space' (SP) and lower case 'z' inclusive, except the '*', in standard ASCII (see last page of manual).

DO Default Operating Parameters

The **Default Operating** command affects four modes of operation - 1) how the HPB handles a command when a parity error occurs, 2) a value that represents the number of HPBs on the RS-232 bus, and 3) noise protection when running in the continuous pressure (**P4**) mode. (Default: **DO=E0N**)

Inquiry: *dd**DO**

Action: *dd**WE**

EEPROM Store: *dd**WE**

*dd**DO**={**E|R**} *or*

*dd**SP**=**ALL**

*dd**DO**=*numHPBs* *or*

*dd**DO**={**N|P**}

E Execute the command in the event of a parity error.

R Reject the command in the event of a parity error.

.....
numHPBs *RS-232 configuration only* A decimal number from 0 to 9.

The number 0 should be used if a single HPB is connected. When 2 or more HPBs are on the bus, the correct number is calculated by dividing the number of HPBs by 10 and rounding up to the next whole number.

.....
N Normal operation.

P Noise protection when running in the P4 continuous mode. This option reduces the change that noise will cause transmission to stop during continuous P4 pressure readings. In this mode, the HPB will respond normally to computer generated commands that are transmitted as a contiguous character string, but will ignore commands that are typed manually.

Note: To run **P4** for an RS-485 unit, the **TO=C** option must be set.

DS Deadband and Sensitivity Control

The **Deadband** and **Sensitivity** control command allows the user to adjust the threshold value that causes a change in pressure reading. There are two option for this, **C** and **S**.

The **C** option sets the deadband to around the center of the pressure reading that moved it last. When the deadband is first set, the deadband will be split half above and half below the current reading. When the pressure exceeds either limit, the new pressure value becomes centered in the deadband limits.

The **S** option sets the deadband based on the peaks and valleys of the pressure level. For instance, when a small peak pressure is sensed, the top edge of the deadband will move to that pressure and have the entire deadband range below this value. The output reading will be one-half the deadband below this pressure (see Figure 4.9b). As long as the pressure stays within the new deadband range the output will not change. If a pressure is sensed below this range, the deadband will move so that the bottom edge will be at that pressure and the entire deadband will be above this value.

Note: For both the **C** and **S** options, there are instances when the transmitted pressure value can be inside the deadband limits. This is due to the integration of the pressure value where multiple pressure samples are used to determine a single pressure reading. If one of the samples falls outside the deadband limits and the average of all the samples falls inside the limits then the transmitted reading will be inside the limits. To avoid this effect, set the integration time to **I=R61**, or greater. Now the transmitted pressure output will be based on a single sample.

The **S2** and **S5** speed shift thresholds can be used to create higher reading rates when pressure is changing, and lower reading rates when pressure is stable within the deadband limits. To eliminate repetitive readings of the same pressure within the deadband set the **OP=U** command. See Figures 4.9a and 4.9b and 4.10 for command illustrations. (Default: **DS = 00S0**)

Inquiry: *ddDS

Action: *ddWE

EEPROM Store: *ddWE

*ddDS= *deadband* or

*ddSP=ALL

*ddDS= *Cn* or

*ddDS= *Sn*

deadband 0 provides no deadband
1-60 provides *deadband* x 0.005% of full scale deadband limits

C Center deadband around each new pressure output change.

S Deadband Spread varies with the peaks and valleys of pressure changes.

n 0 or 1 – provides a deadband multiplier to allow the user to specify a wider set point null span where:

0 provides a 1x multiplier (deadband x 0.005% FS)

1 provides a 10x multiplier (deadband x 0.05% FS)

DU Display Units Control

Set the **Display Units** for compensated pressure replies. A **USER** defined display unit can be set with this command that causes the pressure output to equal the value input by the **U=** command multiplied by the actual pressure in psi units. (Default: **DU=PSI**)

Inquiry: *ddDU

EEPROM Store: *ddWE

*ddSP=ALL

Action: *ddWE

*ddDU= {ATM|BAR|CMWC|FTWC|INHG|INWC|KGCM|KPA|
MBAR|MMHG|MPA|MWC|PSI|USER|LCOM|PFS}

Display Unit	PSI Multiplier ⁽¹⁾	Units Description
ATM	0.068046	ambient atmosphere at sea level
BAR	0.068948	bar (10 ⁵ newtons/meter ²)
CMWC	70.304	centimeters of water column (4 °C)
FTWC	2.3065	feet of water column (4 °C)
INHG	2.0360	inches of mercury (0 °C)
INWC	27.679	inches of water column (4 °C)
KGCM	0.070307	kilograms/centimeter ²
KPA	6.8948	kilopascal
MBAR	68.948	millibar (1 hectopascal)
MMHG	51.714	millimeters of mercury (0 °C) or torr
MPA	0.0068948	megapascal
MWC	0.70304	meters of water column (4 °C)
PSI	1.0000	pounds per square inch
USER	0.0010000-999.99	user supplied (see also U= command)
LCOM	FS=60000	logic common value (2)
PFS	FS=100.000	percent of full scale in 0.001% increments

Table 5.5—Display Units Options

⁽¹⁾ From the *CRC Handbook Of Tables For Applied Engineering Science*

⁽²⁾ The **LCOM** display unit (logic common) automatically switches the digital pressure output to a scale which has 60000 as the full scale output (± 60000 for differential devices). The output will have a decimal point in the same position that it is in with the original psi scale. For example, when a 17.6 psia device is switched to **DU=LCOM**, the full scale digital pressure output will be 60.000, instead of 17.600. If the pressure reading was at zero, then no output change will be seen since zero is the same for any display unit. **LCOM** provides the highest reading resolution available when using the standard output format (**OP=S**).

I=M0 will restore the last setting saved in EEPROM.

IC Idle Count Parameter

The **Idle Count** parameter specifies the number of pressure integration times that the microprocessor skips between output values (see Fig. 4.10). This command is only operational for the **I=Mn** form of the Integration Time (**I=**) command. (See the **I=** command for setting integration times.) This parameter can be used to reduce the average HPB power requirement by as much as 50% when increased response time is acceptable. This parameter is also used to reduce the reply message traffic on the network bus from HPBs whose response time is not critical. The **S2** and **S5** parameters are operational with this parameter to allow integration speed shifting. (Default: **IC=0**)

Note: If the **OP=W** (watchdog timer) command is set, then the **IC** command will not work (other than **IC=0**) and cause an **RS** command error condition.

Inquiry: *dd**IC**

Action: *dd**WE**

EEPROM Store: *dd**WE**

*dd**IC=ICcount**

*dd**SP=ALL**

ICcount 0 to 255

where: 0 causes all integration cycles to be used.
1 causes 1 of 2 integration cycles to be used.
2 causes 1 of 3 integration cycles to be used.
. . .
n causes 1 of n integration cycles to be used.
. . .
255 causes 1 of 256 integration cycles to be used.

If group addressing is to be used for HPB responses, then all HPB's within a single group must have a group sub-addresses assigned sequentially starting with address 01. The command sequence to assign group address 91 and sub-address 01 to an HPB with identification address 03 is:

```
*03WE
*03ID=9101
*03WE
*03SP=ALL
```

See the **TO** command description for further information on RS-485 global addressing.

2) If the HPBs to receive ID addresses have null addresses, they can be installed on the RS-485 bus *one at a time*. After each HPB is connected, its ID address can be assigned by using the above procedure.

3) Any number of null addressed, or unknown addressed, HPBs can be connected to an RS-485 bus and have ID individually assigned by using their serial numbers as unique identifiers. The command sequence to assign the address 02 to an HPB with serial number 3175 is:

```
*99WE
*99S=00003175 (must use all 8 numbers)
*99WE
*99ID=02
*02WE
*02SP=ALL
```

When the identification address has been assigned, group address and sub-address can be assigned in the same manner as in **1)** above.

Note: For RS-485 units, all ***9xID=** commands are ignored unless the command has been preceded by a serial number command (***99S=sssssss**) with the serial number that matches that unit. The next ***9xID** command will set that unit's device ID number.

IN Initialize HPB Microprocessor

This command **IN**itializes the HPB microprocessor. When this command is sent with the **RESET** option, it performs the same start-up function as removing and re-applying power to the HPB (exceptions to this are described in the **MO** command).

Action: ***ddIN**

This stops a continuous read operation but does not perform a power-on reset. All RAM stored parameters are retained.

Action: ***ddIN=RESET**

This stops any current operation and then performs a power-on reset. If the command has a group or global address (90-99), the message is re-transmitted before the power-on reset is activated. All RAM parameters are replaced with EEPROM stored parameters. See **MO** command for reset options.

MO Power-Up Mode

Sets the power-up **MO**de for the HPB. This command does not produce any immediate operational change. However, when stored in the EEPROM with the **SP** command, it causes the specified option(s) to be applied at power-up, at an **IN=RESET** command, or a watchdog timer timeout (if activated). (Default: **MO=X2M1**)

Note: User provided messages may be up to 16 characters long and may contain any information desired by the user. The message is stored in the EEPROM with the **C=** and **D=** commands. When an **M2** power-up option is selected, a message is transmitted starting with the left most character of the **C=** string to the right most character of the **D=** string, or until a space character is encountered. Use the underscore (**_**) character in the **C=** or **D=** message if a space is desired.

Inquiry: *dd**MO**

Action: *dd**WE**

EEPROM Store: *dd**WE**

*dd**MO**={ **X2**|**P2**| **P4**| **T2**| **T4** } or

*dd**SP**=**ALL**

*dd**MO**={ **M0**|**M1**| **M2**| **M3**|**N0**|**N1**| **N2**| **N3** }

- X2** No continuous readings.
- P2** Continuous pressure readings in ASCII format.
- P4** Continuous pressure readings in binary format.
- T2** Continuous Celsius temperature readings.
- T4** Continuous Fahrenheit temperature readings.

Note: To use the **P2**, **P4**, **T2**, or **T4** commands on RS-485 units, the **TO=C** command must be set, and only for *one* unit on the bus.

	Power-up		IN=RESET or watchdog timeout	
	Message (1)	EEPROM checksum (2)	Message (1)	EEPROM checksum (2)
M0	none	no	none	no
M1 (3)	factory	yes	factory	no
M2 (3)	user	no	user	yes
M3 (3)	factory	yes	user	yes
N0 (4)	none	no	none	no
N1	none	yes	none	no
N2	none	no	none	yes
N3	none	yes	none	yes

(1) See Section 2.4 for factory message. See **C=**, **D=** for user message.

(2) See **CK** command for the time it takes to complete the checksum.

(3) For RS-485 mode, only *one* unit should have **M1**, **M2**, or **M3** active.

(4) Same as **M0**.

Warning: it is possible to configure continuous readings at power-up (**MO = P2, P4, T2 or T4**) for RS485 multi-drop HPBs such that the configuration/readings cannot be interrupted or changed. For example, each **P4** mode reading requires 6 characters including carriage return. At 1200 baud, each character (1 start bit, 8 ascii bits, 1 stop bit) takes $10/1200 = 8.33$ ms and 6 characters require $6 * 8.33$ ms = 50 ms. If the HPB integration time is set to $I=R20$, the update rate is $1/20 = 50$ ms. That would leave zero time for your controller/PC to take command of the differential RS485 bus and send a message. Carefully determine that your planned HPB configuration will allow at least one character time for your controller/PC to take control of the bus between continuous readings.

OP Operating Mode Parameters

Sets the **OP**erating mode parameters for the number of decimal places, checksum usage, and sequential read control for pressure readings. It also controls the built-in watchdog timer feature. If enabled, the watchdog timer will perform an automatic system reset, similar to an **IN=RESET** command, if the HPB becomes interrupted due to external influences. This option is useful in applications that are subject to electrical noise, power glitches, electrostatic discharges, etc., or where high reliability is required.

(Default: **OP=ANEX**)

Inquiry: *dd**OP**

Action: *dd**WE**

EEPROM Store: *dd**WE**

*dd**OP**={**A|U**} or *dd**OP**={**N|C**} or

*dd**SP**=**ALL**

*dd**OP**={**E|F|R|S**} or *dd**OP**={**X|W**}

- A** Transmit all readings for sequential requests and continuous mode.
- U** Transmit only changed pressure readings for sequential requests and continuous mode. **Note:** See **DS** command for controlling the amount of pressure deviation that is detected as a change. See **RR** command to skip identical readings. Upon receipt of a **P2** or **P4** command, the HPB will send one reading and then wait for a pressure change before sending another.
-
- N** No checksum.
- C** Apply an integrity Checksum to the binary format readings. When all of the characters in the message, including the header and this character, are added together (without carries) the least significant 6 bits of the resultant sum will be zero. Do not include the <cr>; that is, if you add the 6 least significant bits of the—header, 4 data, and checksum—characters, without any carries, the 6 least significant bits will be zeroes (see Table 5.2 for the list of characters to be used.)
-
- E** Extended form for the commands (P3, P4) using the binary format. This yields a 7 bit binary device address and a 17 bit magnitude for the pressure reading. The pressure sign is encoded in the header character. This allows up to 90,000 counts in the pressure A/D conversion cycle, and allows digital readings (**P1**, **P2**) up to a full scale value of 90,000 to use five significant digits.
- F** Fixed sign position provides the same function as **E** option above but forces a sign position for the **P1** and **P2** readings. With this option the pressure readings do not shift positions when the sign changes from + to - on gauge and differential HPBs.
- R** Remove header characters from **P1** and **P2** pressure readings. Provides the same function as **E** and **F** options above. The first transmitted byte will be the pressure sign character followed by the pressure value and a <cr>. In this mode, there is no device ID number or indication of out-of-range pressure condition in the **P1** and **P2** modes.
- S** Signed form for the commands (P3, P4) using the binary format. This yields a 7 bit binary device address and a sign + 16 bit magnitude for data. This allows up to 60,000 counts in the pressure A/D conversion cycle. If the FS value is set above 60,000 counts, then only four significant digits will be displayed instead of five.
-
- X** No watchdog timer enabled.
- W** Watchdog timer enabled to reset the HPB if it should stop for ~50 msec. See above for application uses.

Note: If the **IC** command is set to any value other than **IC=0**, then the **OP=W** command will not set and cause an **RS** command error condition.

P= Production Date

The **P**roduction date command reads the factory set HPB manufactured date with format mm/dd/yy. If the response has an '!' character instead of '=', there was an EEPROM parity error.

Inquiry: *ddP=

P1 Pressure, Single, ASCII Format

The **P1** command requests a temperature compensated pressure (CP) reading in ASCII format. Refer to Table 4.2 for default decimal placement and significant digits. When this command has a group or global address (***9d**), it is a sequential request command and the **OP=A** or **U** 'all or changes only' parameter controls the output. If this command is executed while a **P2**, **P4**, **T2**, or **T4** command is executing, then one ASCII pressure reading is transmitted and the continuous command resumes operation.

Note: If a group or global **P1** or **P3** command is sent and the pressure reading for that integration cycle has been read before, then the HPB will not send any pressure value.

Note: The HPB continuously integrates and calculates pressure and temperature readings. When this command is received, the latest available reading is transmitted if there is sufficient RS-232 output buffer space. A group or global address command echo of ***9dP1!** indicates that RS-232 buffer space was not available for one of the addressed HPBs.

Inquiry: *ddP1

A response of **#ddCP!0.0000** either indicates the pressure is at zero and a temperature over/under range occurred *or* there is an EEPROM parity error. Check **RS** for specific error. If a parity error occurred, then send a ***ddIN=RESET** command or cycle the power off and on.

A response of **#01CP=.** indicates that no pressure reading is available yet. Try again. This response can be a result of a **P1** request after a **DU**, **BP** (parity change), or **ID** action command or during the power-up cycle before valid data is available.

P2 Pressure, Continuous, ASCII Format

The **P2** command requests continuous temperature compensated pressure readings in ASCII format. The reading rate is controlled by the **IC**, **S2**, **S5**, **OP** and **RR** command settings. See the **DO=P** or **N** commands for the suspend readings options. For RS-485 mode, the **TO=C** command must be set to transmit continuous readings. See the two response descriptions at the bottom of the **P1** command description.

Inquiry: *ddP2

Type: ***\$ddIN** or ***ddIN** To stop a single HPB from continuous pressure reading.

Type: ***\$99IN** or ***99IN** To stop the continuous readings for all HPBs on the bus.

Note: For RS-485 units, when the continuous transmit parameter is **NOT** active (is not set to **TO=C**), the **P2** command sends only *one* reading.

Note: The '*' character will temporarily suspend continuous pressure readings. Pressure readings will resume with a carriage return. The ***ddIN** command disables the continuous output function.

P3 Pressure, Single, Binary Format

The **P3** command produces a single temperature compensated pressure reading in a 6 byte binary format; a 1 byte header character, 4 bytes encoded address and pressure data, and a 1 byte <cr> character (see Section 5.6—Binary Format Replies). Refer to Table 4.1 for default decimal placement and significant digits.

When this command has a group or global address (dd=90-99), it is a sequential request command. When this command has a group or global address (***9d**), it is a sequential request command and the **OP=A** or **U** ‘all or changes only’ parameter controls the output. If this command is executed while a **P2**, **P4**, **T2**, or **T4** command is executing, then one ASCII pressure reading is transmitted and the continuous command resumes operation.

The **OP** command also controls whether an integrity checksum is to be inserted between the last data byte and the <cr> character. See **OP** command for checksum calculation.

Note: See the two notes in **P1** command

Inquiry: *dd**P3**

Typical reply: {#@#16 Binary format compensated pressure reading from device **ID=01** is 15.478 inH₂O; refer to Table 5.1 and 5.2

If reply is xx??? or Binary format compensated pressure reading not available yet, xx_?? request again. The ‘xx’ is the header character and the 6 most significant bits of the address.

P4 Pressure, Continuous, Binary Format

The **P4** command produces a continuous stream of temperature compensated pressure readings in a 6 byte binary format; a 1 byte header character, 4 bytes encoded address and pressure data, and a <cr> character (see Section 5.6—Binary Format Replies). See **P3** for typical reply. See the **DO=P** or **N** commands for suspend readings from a **P4** command.

For RS-485 mode, the **TO=C** command must be set to transmit continuous readings.

The **OP** command also controls whether an integrity checksum is to be inserted between the last data byte and the <cr> character. See **OP** command for checksum calculation.

Inquiry: *dd**P4**

Type: \$***ddIN** or ***ddIN** To stop a single HPB from continuous pressure reading.

Type: \$***99IN** or ***99IN** To stop the continuous readings for all HPBs on the bus.

Note: For RS-485 units, when the continuous transmit parameter is **NOT** active (is not set to **TO=C**), the **P4** command sends only *one* reading.

Note: The ‘*’ character will temporarily suspend continuous pressure readings. Pressure readings will resume with a carriage return. The ***ddIN** command disables the continuous output function. If **DO=P**, RS485 units will require a computer generated contiguous character string of ***ddIN** to disable continuous pressure readings. Manually typed character strings will not disable continuous pressure readings if an RS485 unit is configured with **DO=P**.

RR Reading Rate

The **Reading Rate** command specifies the number of identical readings to skip after a pressure reading has been transmitted before making another reading available. The **TO=C** command option must be set. The sensitivity to pressure changes and deadband is controlled by the **DS** command. (Default: **RR=0**)

Note: This command is only operational when **OP=U** is used.

Inquiry: *dd**RR**

Action: *dd**WE**

*dd**RR**=*readRate*

EEPROM Store: *dd**WE**

*dd**SP**=**ALL**

readRate 0 to 10

where: 0 Transmit every reading.

1-10 Requests that *readRate x100* identical readings be skipped after each transmission. When this number has been reached, the current pressure reading is transmitted, to provide an “I am still here” confirmation.

RS Read Status

The **Read Status** command is used to determine if an error or warning condition has been detected by the HPB. The act of reading the **RS** command clears the error or warning indicators except for EEPROM checksum errors, which require two **RS** commands to clear.

If a sequential **RS** command is issued with the form: ***9dRS**, only addressed HPBs with one or more error indications in the status register will respond; e.g., if the ***9dRS** command is returned with no response, then no errors exist.

If a sequential **RS** command is issued with the form: ***9dRS=**, then all addressed HPB's respond in connected sequential order, whether an error exists or not. This form can be used to get a sequential "I am here and OK" response from all HPBs. An ***9dRS!** or ***9dRS!=** echo response indicates one or more addressed HPBs had status data to transmit but did not have sufficient buffer space due to bus traffic. The **RS** command should be re-executed.

Inquiry: ***ddRS** or ***ddRS=**

Replies: **?ddRS=pqrs** (null address) **#ddRS=pqrs** (assigned address)

Where:

p = 0 No EEPROM error
p = 1 EEPROM characterization table checksum error
p = 2 EEPROM control checksum error
p = 3 EEPROM characterization/control checksum error
p = 4 EEPROM parity error
p = 5 EEPROM parity/characterization checksum error
p = 6 EEPROM parity/control checksum error
p = 7 EEPROM parity/characterization/control error
p = 8 EEPROM parity error for **A=**, **B=**, **C=**, **D=**, **M=**, **P=**, **S=**, and start-up header response.

q = 0 No Command Error
q = 1 Command Error

r = 1 Digital communications framing error
r = 2 Digital communications parity error
r = 3 Digital communications framing and parity errors

s = 0 No temperature or pressure range errors
s = > Over temperature condition
s = < Under temperature condition
s = + Over pressure condition (>1% over FS)
s = - Under pressure condition (>1% under lower limit)
s = B Microprocessor bandwidth warning
s = G Internal signal noise detected, which indicates a grounding problem
s = W Watchdog timer interrupt occurred or an **IN=RESET** was executed

A pressure-over-range error condition will occur when the applied pressure is greater than or equal to 1% of full scale (FS) above the FS limit. For example, if the pressure applied to a 17.6 psi unit is >17.776 psi, then an over range error condition is set. Similarly, an under range condition occurs when the applied pressure is greater than or equal to 1% FS below the minimum limit. If the temperature exceeds the limit values (-40 and 85 °C), then the over/under temperature error flag is set. The temperature output reading will remain at the limits. If there had been an over **and** an under-range condition, then the first **RS** inquiry reply will be "000+", the second will be "000-" and the third will be "0000".

The maximum pressure reading is 105 percent of FS. This limit varies slightly from device to device but will continue to display the out-of-range indicator (“!” in place of “=”) until the pressure drops below 101 percent of FS.

Note: In the unlikely event of EEPROM checksum errors, the temperature and pressure integration cycles stop. This can be overridden by executing two **RS** commands consecutively, which clears the error indications. Pressure and temperature readings can then be taken; however, the readings may not be correct. Also, the fourth error indicator is prioritized in the order shown. When the **RS** command is issued with a group or global address (sequential mode), only HPBs which have at least one error condition will respond. Replies are in sequential RS-232 bus loop connection order, followed by the return of the **RS** command.

Out-of-range temperature has display precedence over out-of-range pressure, which in turn has precedence over microprocessor bandwidth warning, which is followed in precedence by noisy signal ground warning. The indication is cleared only if the condition no longer exists. If temperature out-of-range, pressure out-of-range, and microprocessor bandwidth warning all existed, then with successive **RS** commands, the first command would show the temperature condition, the second command would show the pressure condition, the third command would show the bandwidth warning, and the fourth command would show no error.

S= Serial Number

The **Serial number** command reads the factory set HPB serial number. If the response has an ‘!’ character instead of ‘=’, there was an EEPROM parity error.

Inquiry: *dd**S=**

RS-485 type only

In multidrop bus configuration only this command must be used to identify an HPB for address assignment. Command *99**S=**sssssss, where sssssss is the 8 character serial number of the HPB (in this case the leading zeros of the serial number must be used because the identification match is made on all 8 ASCII characters—not the decimal value of the serial number), identifies the HPB for identification address assignment. The address assignment is then performed by a *99**ID**nn command, where nn is the address.

Note: If two HPB units on an RS-485 bus have the same ID then you can use the sequence below to re-assign ID numbers

Action: *99**WE**

*99**S=**sssssss (this allows the HPB to accept the next *99**ID** command)

*99**WE**

*99**ID=**nn (this assigns the HPB #sssssss the ID number ‘nn’)

Where: sssssss is the HPB serial number with sufficient leading zeros to provide 8 characters.

S2 Speed Shift x2

The Speed shift x2 command specifies the threshold at which the pressure integration speed doubles; e.g., the integration time is halved. When the pressure change rate falls below the threshold, the HPB resumes transmission at its configured output rate. This command is only operational when the **I=Mn** form of the Integration command is used. See Figure 4.7 for command illustration. (Default: **S2=0**)

Inquiry: *ddS2

Action: *ddWE

EEPROM Store: *ddWE

*ddS2=*thresholdS2*

*ddSP=ALL

thresholdS2 0 to 15

where: 0 Disable the x2 speed shift function.

1-15 Sets the speed shift threshold for double speed at *thresholdS2* x 0.01% FS reading times (threshold = 0.01%FS x *thresholdS2*).

S5 Speed Shift at 50msec Intervals

The Speed shift S5 command specifies the threshold at which the pressure integration speed changes to outputting every 50 milliseconds. When the pressure change rate falls below the threshold, the HPB resumes transmission at its configured output rate. The 50 msec interval is synchronous with the configured output rate. This command is only operational when the **I=Mn** form of the Integration command is used. See Figure 4.8 for command illustration. (Default: **S5=0**)

Inquiry: *ddS5

Action: *ddWE

EEPROM Store: *ddWE

*ddS5=*thresholdS5*

*ddSP=ALL

thresholdS5 0 to 15

where: 0 Disable the S5 speed shift function.

1-15 Sets the speed shift threshold for 50 msec intervals at *thresholdS5* x 0.01% FS reading times (threshold = 0.01%FS x *thresholdS5*).

SI Synchronize Integration Cycles

RS-485 type only

The Synchronize Integration command is used to control the start of an HPB's pressure integration cycle. When used with group or global addressing on an RS-485 bus, this command simultaneously starts the pressure integration cycles of all addressed HPBs on the bus. The results of pressure integration cycles completed *prior* to the execution of this command are either preserved for reading or discarded, depending on the operational configuration specified by the **TO=C, A, S, or H** command. The new integration cycle (**I=**) begins immediately following the carriage return (<cr>) entry of the **SI** command. See Figure 4.11 for command illustration.

Action: *ddSI

Setting:

TO=C, or A

TO=S

TO=H

When an **SI** command is sent:

Restart **I=** cycle

Restart **I=** cycle, Clear previous **I=** value

Restart **I=** cycle, Clear previous **I=** value, Stop after 1 **I=** cycle

SP Store Parameters in EEPROM

The **Store Parameters** command causes all control parameter(s) to be stored in the EEPROM so they are available when power is applied. Only changes are updated, and if an update is made, the control parameter EEPROM checksum is automatically recalculated.

Note: This command will not work when a ***ddWE=RAM** continuous write enable is active. It must have a singular write enable (***ddWE**) command preceding it.

Action: ***ddWE**
 ***ddSP= All** Writes all parameters to EEPROM.

T1 Temperature, Single, °C

The **T1** command requests a single temperature reading in degrees Celsius. The reading resolution is 0.1 degrees C. When this command has a group or global address, it is a sequential request command. (Factory default is °C, after that, the default will be the last reading type, °C or °F, which is stored in EEPROM during a **SP=ALL** command.)

A response of **#01CT=.** indicates that no temperature reading is available or the last reading was in Fahrenheit. If the last reading was in Fahrenheit, then it will take a second inquiry by the user to get the first reading. Successive readings in Celsius only take one inquiry.

A group or global address command echo of ***9dT1!** indicates that RS-232 buffer space was not available for one or more of the addressed HPBs.

Note: The HPB continuously integrates and calculates pressure and temperature readings. When this command is received, the latest available reading is transmitted if there is sufficient output buffer space.

Inquiry: ***ddT1**

T2 Temperature, Continuous, °C

The **T2** command requests continuous temperature readings in degrees Celsius. Reading rate is controlled by the **IC** command setting. The reading resolution is 0.1 degrees C. (Default - see T1 command)

Inquiry: ***ddT2**

Type: ***\$ddIN** or ***ddIN** To stop a single HPB from continuous temperature reading.

Type: ***\$99IN** or ***99IN** To stop the continuous readings for all HPBs on the bus.

Note: For RS-485 units, when the continuous transmit parameter is **NOT** active (is not set to **TO=C**), the **P2** command sends only *one* reading.

Note: The ***** character will temporarily suspend continuous temperature readings. Temperature readings will resume with a carriage return. The ***ddIN** command disables the continuous output function.

T3 Temperature, Single, °F

The **T3** command requests a single temperature reading in degrees Fahrenheit. The reading resolution is 0.1 degrees F. (Factory default is °C, after that, the default will be the last reading type, °C or °F, which is stored in EEPROM during a SP=ALL command.)

A response of **#01FT=.** indicates that no temperature reading is available or the last reading was in Celsius. If the last reading was in Celsius, then it will take two inquiries to get the first reading. Successive readings in Fahrenheit will only take one inquiry.

A group or global address command echo of ***9dT1!** indicates that RS-232 buffer space was not available for one or more of the addressed HPBs.

Note: The HPB continuously integrates and calculates pressure and temperature readings. When this command is received, the latest available reading is transmitted if there is sufficient output buffer space.

Inquiry: *ddT3

T4 Temperature, Continuous, °F

The **T4** command requests continuous temperature readings in degrees Fahrenheit. RS-232 reading rate is controlled by the IC command setting. The reading resolution is 0.1 degrees F. (Default - see T1 command)

Inquiry: *ddT4

Type: ***\$ddIN** or ***ddIN** To stop a single HPB from continuous temperature reading.

Type: ***\$99IN** or ***99IN** Stops the continuous temperature reading for all HPBs on the bus.

Note: For RS-485 units, when the continuous transmit parameter is **NOT** active (is not set to **TO=C**), the **P2** command sends only *one* reading.

Note: The '*' character will temporarily suspend continuous temperature readings. Temperature readings will resume with a carriage return. The ***ddIN** command disables the continuous output function.

TO Transceiver Operating Parameters

Sets the Transceiver Operating parameters for the RS-232, or RS-485, transceiver interface protocol. The **TO=R** or **M** commands can select either a ring *or* multidrop configuration for RS-232 type HPBs, or a multidrop configuration *only* for RS-485 type HPBs. All other command parameters apply only to the multidrop RS-485 configuration. See Figure 4.11 for **TO=A**, **S**, and **H** command illustrations.

(Default: **TO=R0CN** for RS-232 type or **TO=M1CN** for RS-485 type)

Inquiry: *dd**TO**

Action: *dd**WE**

EEPROM Store: *dd**WE**

*dd**TO**={**R**|**M**} or *dd**TO**={**0-3**} or

*dd**SP**=**ALL**

*dd**TO**={**C**|**A**|**S**|**H**} or *dd**TO**={**N**|**P**}

- R** Ring protocol for RS-232 units. This parameter option *cannot* be selected for the RS-485 type.
- M** Multidrop protocol for RS-485 units. This option *can* be selected for RS-232 unit, but requires an external RS-232 to RS-485 converter. If an RS-232 unit has **TO=M** selected, then all the options labeled “RS-485 only” apply.

-
- 0-3** Controls the minimum command response delay, RS-485 bus turn around time. For baud rate of 9600 and below, each count (0-3) represents about 1 millisecond. For baud rates above 9600, each count represents one character transmission time. This feature has no effect on RS-232 units.

Baud	1200	2400	4800	9600	14400	19200	28800
time/count	1 ms	1 ms	1 ms	1 ms	0.7 ms	0.5 ms	0.3 ms

-
- C** Allows an RS-485 unit to transmit Continuous pressure readings (**P2** or **P4**) when the device ID is used. This parameter has no effect on RS-232 units.
- A** **RS-485 only:** Causes the **SI** command to start a pressure integration cycle and *not* clear the result of the previous cycle so it can be read with a **P2** or **P4** command if the result has not been previously read. When the synchronized cycle completes a new cycle is immediately started.
- S** **RS-485 only:** Causes the **SI** command to start a pressure integration cycle and clear the result of the previous cycle so that a **P2** or **P4** command produces a “pressure reading not available” indication (<cr> only) if a **P2** or **P4** read attempt is made before the new integration cycle completes. When the synchronized cycle completes, a new cycle is immediately started. If the pressure reading produced by the synchronized cycle is to be read it must be read before the next integration cycle completes
- H** **RS-485 only:** Causes the **SI** command to start a pressure integration cycle and clear the result of the previous cycle so that a **P2** or **P4** command produces a “pressure reading not available” (<cr> only) if a **P2** or **P4** read attempt is made before the new integration cycle completes. When the synchronized cycle completes, the pressure reading is **Held** until it is read or until a new **SI** command is issued.

Setting:

When an **SI** command is sent:

TO=C, or **A**

Restart **I=** cycle

TO=S

Restart **I=** cycle, Clear previous **I=** value

TO=H

Restart **I=** cycle, Clear previous **I=** value, Stop after 1 **I=** cycle

N Normal read operation response. This parameter has no effect on RS-232 units. In RS-485 mode, each HPB will respond to a group or global read operation after the unit with the next lower device ID (for global) or next lower sub-address (for group) has responded. Device ID, and group sub-addresses, must be sequential beginning with number 01.

P **RS-485 only:** Prompted read operation response. In RS-485 mode, after the lower addressed HPB responds to a group or global read operation, this HPB will not respond until it is prompted by a <cr> from the bus system host. The <cr> may also be manually entered by the user to get each successive response. To receive data from each prompt, the device ID, or group sub-addresses, must be sequential beginning with number 01.

Note: If an RS-485 unit receives a group or global addressed (***9x**) command and fails to respond, the command terminates at that point until additional carriage returns are received. Usually, the reason for failure to respond is that the device IDs or group sub-addresses were not sequential beginning with number 01.

U= User Supplied Display Units

The User supplied display units command allows the user to enter units of measure for the HPB. The value entered for this command is multiplied by the actual pressure in psi to get the user defined units. For example, if ***ddU=15.0<cr>**, then the compensated pressure output values will be 15 times the actual psi value. This function (multiplier) is activated by executing the ***dddU=USER<cr>** command. If there is an input error, then the command error flag in the **RS** command will be set and no change will occur.

Inquiry: ***ddU=**

Action: ***ddWE**

***ddU=UserValue**

EEPROM Store: ***ddWE**

***ddSP=ALL**

UserValue Must be a value between 0.0010000 and 999.99. It is advisable to confirm the setting by executing a ***ddU=<cr>** command after the **U=** setting is established. The user supplied display function is activated by executing the ***dddU=USER<cr>** command.

V= Version Number

This Version number command transmits the factory set software version number.

Inquiry: ***ddV=**

Reply: **#01V=02.4C5S2V**

02.4C5 Software version number

S HPB Type

2 or 4 Digital Output

2: RS-232

4: RS-485

WE Write Enable to EEPROM or RAM

The Write Enable command enables an EEPROM write or a RAM write operation. It is used as a safeguard to prevent erroneous command sequences from changing the HPB configuration. A ***ddWE** command must immediately precede the **SP**, **A=**, **B=**, **C=** or **D=** commands when storing information in the EEPROM. The ***ddWE** command must also immediately precede any command that changes the configuration parameters in the RAM. When manually making multiple configuration changes, ***ddWE=RAM** command form may be used to permanently enable RAM updates until the next ***ddWE** or ***ddWE=OFF** command is executed.

Note: The ***ddWE** command remains active until the next ***** followed by a **<cr>** is received, or a ***9.<cr>** passes through from a group or global addressed command.

Action: ***ddWE**

This enables the next command to write to the RAM or EEPROM, and also disables the ***ddWE=RAM** condition after the next command is received.

Action: ***ddWE=RAM**

This provides a permanent RAM write enable. All commands following a ***ddWE=RAM** will be stored in RAM. A ***ddWE** command will disabled, or deactivate, this permanent RAM write enable. The ***ddWE=RAM** command will not allow the **SP** command to write to EEPROM.

Action: ***ddWE=OFF**

This immediately disables the ***ddWE=RAM** condition.

X= Slope 1—User Compensation Control

The user can adjust the pressure vs. output curve using the **X=** and **Z=** commands. The **X=** command adjusts the slope of the pressure output curve. The range of adjustment is $\pm 0.6\%$ FS in 0.005% increments. Use the modified full scale value if the **F=** command is set. If there is an input error, then the command error flag in the **RS** command will be set and no change will occur. See Figure 4.3 for command illustration. (Default: **X=0**)

Inquiry: ***ddX=**

Action: ***ddWE**

***ddX=pp**

EEPROM Store: ***ddWE**

***ddSP=ALL**

pp **0 to ± 120** This number adjusts the pressure reading by multiplying it by 0.005% and scaling the slope of the pressure reading before output.

$$\text{Pressure Output} = [1 + (pp \times 0.00005)] \times \text{Pressure Reading}$$

Z= Offset—User Compensation Control

The user can adjust the pressure vs. output curve using the X= and Z= commands. The Z= command adjusts the offset of the pressure output curve. The range of adjustment is $\pm 0.6\%$ FS in 0.005% increments. Use the customized full scale value (F=) as a multiplier.

If there is an input error, then the command error flag in the RS command will be set and no change will occur. See Figure 4.4 for command illustration. (Default: Z=0)

Inquiry: *ddZ=

Action: *ddWE

EEPROM Store: *ddWE

*ddZ={pp|CAL|REF|SET}

*ddSP=ALL

pp 0 to ± 120 This number adjusts the pressure reading by adding (pp x 0.005% FS) to the reading before outputting.

$$\text{Pressure Output} = [(pp \times 0.00005) \times (M = \text{full scale})] + \text{Pressure Reading}$$

CAL Sets the zero pressure condition to zero output. Offset is calculated and stored, then applied to all readings thereafter. Set Z=0 to cancel. The range of correction for the CAL command is the same as pp described above. If the correction is out of range, then the Z= parameter will be set to a maximum value (+120 or -120).

Note: When the Z=CAL command is executed and there is a deadband (DS) set, the output may not read zero when it actually is. To read zero pressure, turn the deadband off (DS=0).

\$ Suspend Continuous Readings

This is not actually a command but a special command header character. During a continuous pressure reading command, P2 or P4 in RS-232 ring configuration or when the bus noise protection parameter is used (DO command) in multidrop configuration, a '\$' by itself will temporarily stop, or suspend, transmission. Pressure readings will continue to be taken at the configured rate but will not be transmitted on the RS-232 outputs. This allows for manual entry of a command when continuous readings are filling the display. Pressure reading transmission will resume when the <cr> carriage return (ENTER key) is pressed.

Note: Under some conditions it is possible to enter a command that will not cause continuous readings to resume after entering the <cr> character, in which case a second <cr> will cause the continuous readings to resume.

Example: *ddP2 (Start continuous pressure readings)

\$*ddV= (Suspend continuous pressure readings to read version number)
(Resume continuous pressure reading after the V= reply)

6 ELECTRICAL CONNECTIONS

HPB	HPB-CE	Signal Name
1	A	RS-232 (TD) / RS-485 (B)
2	B	RS-232 (RD) / RS-485 (A)
3	C	Case/Earth Ground
4	D	Common Ground (GD)
5	E	DC Power In
6	F	NC

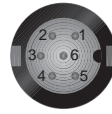

HPB Connector
(pins—top view of HPB)

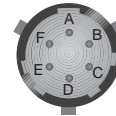

HPB-CE Connector
(pins—top view of HPB-CE)

HPB Mating Connector
Conxall P/N 6-282-6SG-522 Newark Stock no. 89F4115

HPB-CE Mating Connector
ITT Cannon P/N MS3116F10-6S Newark Stock no. 93F3377

Figure 6.1—HPB and HPB-CE Electrical Connector Pin Assignments

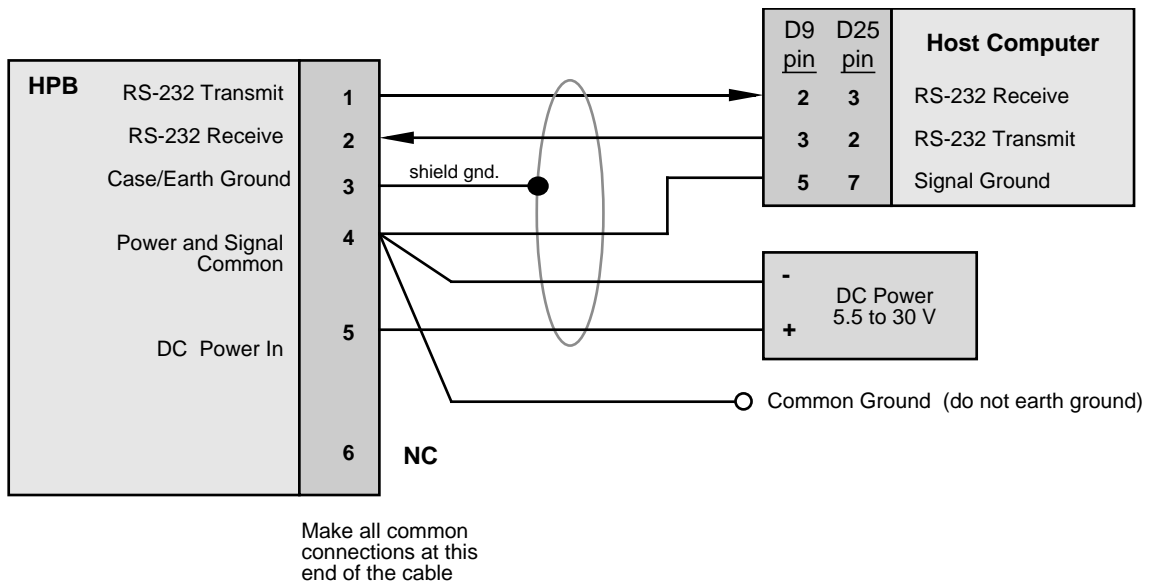
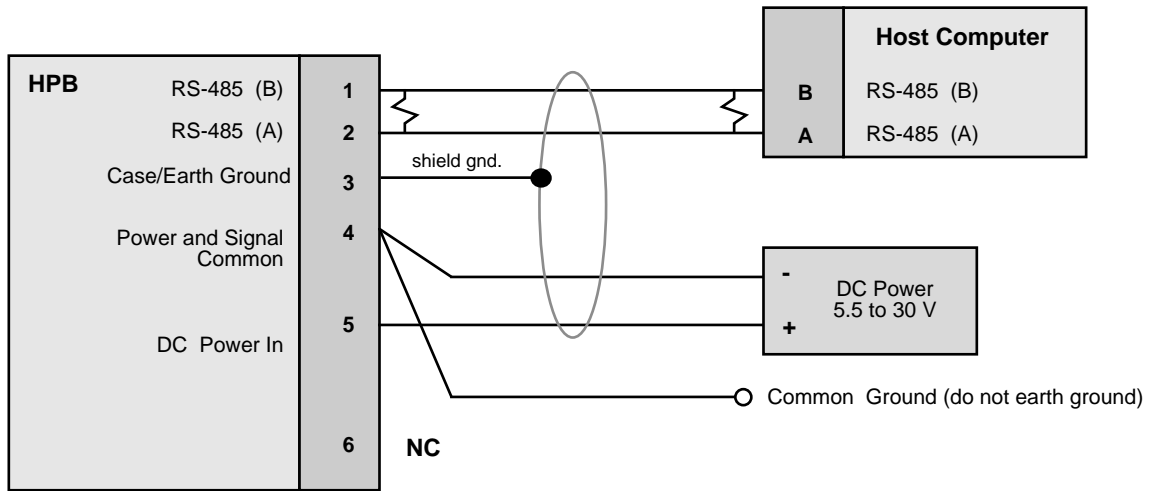

Figure 6.2—Connection for RS-232 Operation



Make all common connections at this end of the cable.

Figure 6.3—Connection for RS-485 Operation

7 TIMING DIAGRAMS

For the factory default settings, the HPB will respond to a **P1** or **P3** pressure reading with an integration time of 200 msec at 9600 baud data output. The timing for this is shown Figure 7.1. The RS-232 command input time, **Y**, is the transmission time for the command message. This is equal to the number of command characters plus the <cr> character, times the baud transmission time per byte (***01P1**<cr> = 6 x (byte times)). The integration and calculation times are internal HPB times. The integration time is user controlled with the **DI** command. The RS-232 pressure reading output time, **X**, is the reply transmission time. Character, byte or transmission times for different baud rates are listed in Table 7.1. Reply character lengths, **X**, are listed in Table 7.2.

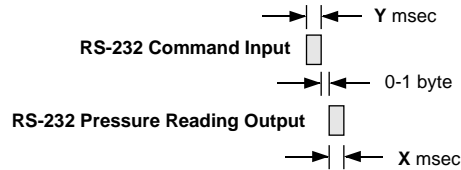

(See Tables 7.1 and 7.2 for X times)

Figure 7.1—Default Single Pressure Reading Timing Diagram

When I=Mn mode or I=R30 (or less) mode:

For continuous pressure reading commands (**P2** and **P4**), the HPB internal times and the output timing are shown Figure 7.2.

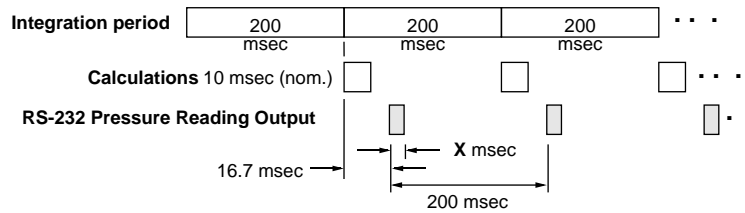

(See Tables 7.1 and 7.2 for X times)

Figure 7.2—Default Continuous Pressure Reading Timing Diagram

For continuous pressure reading commands (**P2** and **P4**) and an **IC=1** setting, the HPB internal times and the output timing are shown Figure 7.3.

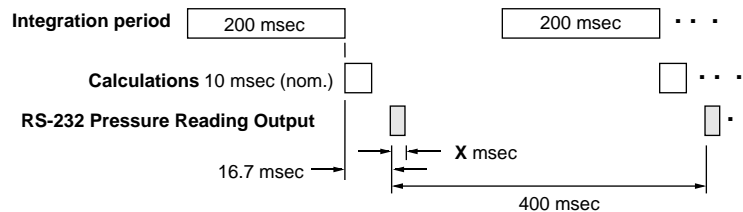

(See Tables 7.1 and 7.2 for X times)

Figure 7.3—Continuous Pressure (with IC = 1) Timing Diagram

Shown below in Figures 7.4 to 7.6 are the timing diagrams for faster pressure output rates - up to 120 readings/second. These rates are achieved by setting the integration time (**I=**) command. For the continuous reading commands P2 and P4, three pressure output timing figures are shown below.

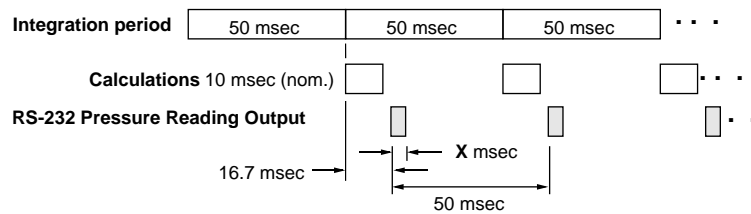

(Integration Time = 50 msec, I=R20)

(See Tables 7.1 and 7.2 for X times)

Figure 7.4—Timing Diagram for 20 Readings Per Second

When I=R31 (or more) mode:

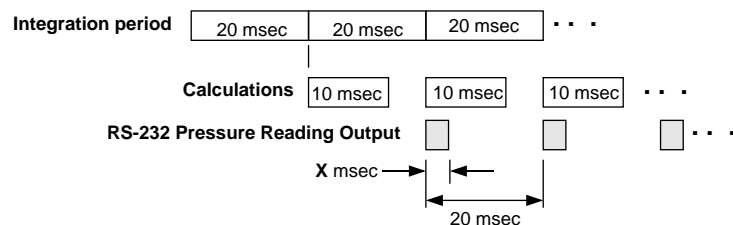

(Integration Time = 20 msec, I=R50)

(See Tables 7.1 and 7.2 for X times)

Figure 7.5—Timing Diagram for 50 Readings Per Second

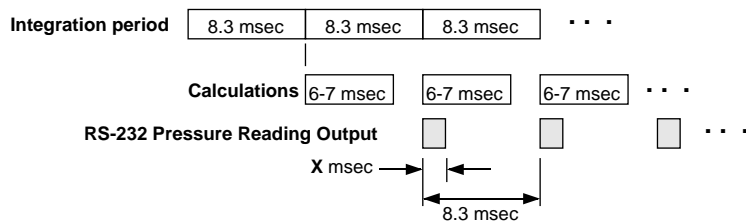

(Integration Time = 8.3msec, I=R120)

(See Tables 7.1 and 7.2 for X times)

Figure 7.6—Timing Diagram for 120 Readings Per Second

Two command examples for calculating the digital transmission times are shown below. These examples are for 9600 baud selection.

	Message	# of Characters	Transmission Time
ASCII			
Inquiry:	*23P1<cr>	6	6.24 msec
Reply:	#23CP=-16.437<cr>	14	16.64 msec
Binary			
Inquiry:	*23P3<cr>	6	6.24 msec
Reply:	^@PSA	6	6.24 msec

Baud Rate (bps)	Time/Character (msec) ⁽¹⁾
1200	8.33
2400	4.17
4800	2.08
9600	1.04
14400	0.694
19200	0.521
28800	0.347

(1) Time is same for No, Even, or Odd parity selection

Table 7.1—Transmission Times at Selected Baud Rate

Reply from:	# of Characters ⁽¹⁾	Format
P3, P4 no checksum	6	Binary
P3, P4 with checksum	7	Binary
P1, P2 min. length	12	ASCII
P1, P2 max. length	16	ASCII
T1, T2, T3, T4	12	ASCII
Other Replies	11	ASCII

(1) Includes <cr> character

Table 7.2—Number of Bytes in Various Replies

8 SPECIFICATIONS

SPECIFICATIONS	HPB	HPA
Pressure Range ⁽²⁾	500-1200 mBar (Note: 1 mBar = 1hPa)	0 - 17.6 psia
Overpressure ⁽³⁾	4150 mBar	60 psia
Burst Pressure ⁽⁴⁾	48 x 10 ³ mBar	700 psia
Operating Temperature Range ⁽⁵⁾	-40 to 85°C (-40 to 185°F)	
Storage Temperature Range	-55 to 90°C (-67 to 194°F)	
Media Compatibility	Suitable for non-condensing, non-corrosive, non-combustible gasses	
Accuracy over Operating Temperature Range ⁽¹⁾		
HPB100 and HPA100	± 0.8 mBar	± 0.06% FS
HPB200 and HPA200	± 0.4 mBar	± 0.03% FS
Stability	0.25 mBar per year	0.02% FS per year
Resolution	0.0011% FS	
Temperature Readings	Within +/- 1.0 C (at sensing element)	
Outputs	RS-232 or RS-485	
Power Requirements	5.5 to 30VDC, <=35mA actual value depends on the configuration	
Weight	5 oz. (142g)	
Bus Addressing	Unique addresses 1 - 89, user assignable	
Baud Rate	1200, 2400, 4800, 9600, 14400, 19200, 28800	
Pressure Units	atm, bar, cmwc, ftwc, mBar, inHg, inwc, Kg/cm, KPa, mBar, mmHg, MPa, mwc, psi user, lcom, pfs	
Response Delay	Delay in ms = (1000/update rate) + 1ms ⁽⁶⁾ or 17ms, whichever is greater.	
Sample Rate	1 sample every 51.2 minutes to 120 samples/sec	
Mechanical Shock	1500 G for 0.5 msec half sine (per MIL-STD-833D, M2002.3, Cond B)	
Thermal Shock	24 cycles from -55 to +90°C (-67 to 194°F), 1 hr cycles	
Vibration	0.5 in. or 20 G's, 20 Hz to 2 KHz (per MIL-STD-833D, M2007.2, Cond A)	
Humidity Sensitivity	Negligible	
Acceleration Sensitivity	Negligible	

(1) Sum of worst case linearity, repeatability, hysteresis, thermal effects, and calibration errors from -40 to 85°C. Consult Honeywell for other accuracy options.

(2) Consult Honeywell for other pressure ranges.

Note: HPB units meet accuracy specifications over 500 - 1200 mBar pressure range. HPB units are fully characterized and will provide digitally compensated pressure values over the entire 0-1200 mBar range.

(3) Exposure to overpressure will not permanently affect calibration or accuracy of the unit.

(4) Exceeding burst pressure rating may result in media escape.

(5) Consult Honeywell for other temperature ranges.

(6) The user-selectable update rates vary between 8.33 ms and 12 sec. Time to first reading is ~300 ms.

• **Digital Output:** (*RS-232 or RS-485*)

Baud Rates: 1200, 2400, 4800, **9600**, 14400, 19200, 28800
Data Framing: 1 start bit, 8 data bits, 1 stop bit
Parity: **No parity**, even parity or odd parity
Handshaking: Not supported
Addressing: 89 individual (self numbering, or user assigned)
9 group addresses (multicast)
1 global address (broadcast)
1 null address (address not assigned)
Bus Operating Modes: Response to a designated unit request.
Sequential response to selected units request.
Sequential response by all units to a single request.
Continuous response by any (or all for RS-232) units.

• **Pressure Units:**

Digital: psi, mbar, bar, kPa, MPa, in. Hg, mm Hg,(torr), in. wc, ft. wc, m wc, cm wc, kg/cm², atm, LCOM, %FS, or user defined. (wc=water column @ 4°C, Hg @ 0°C)

9 DIMENSIONS

DIMENSIONS ARE IN INCHES (CENTIMETERS)

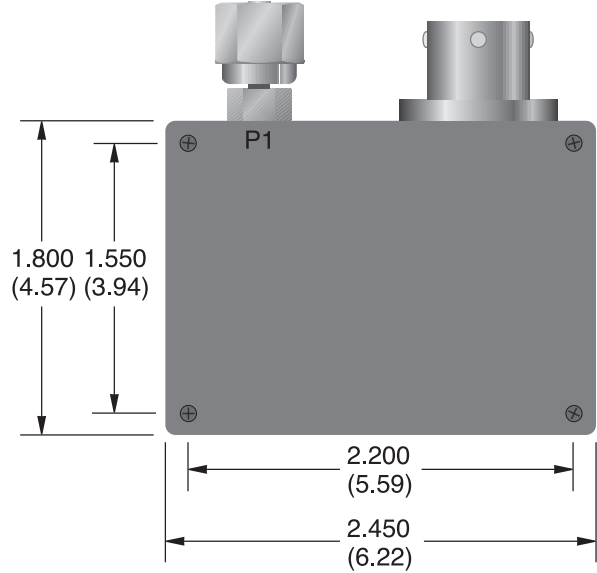
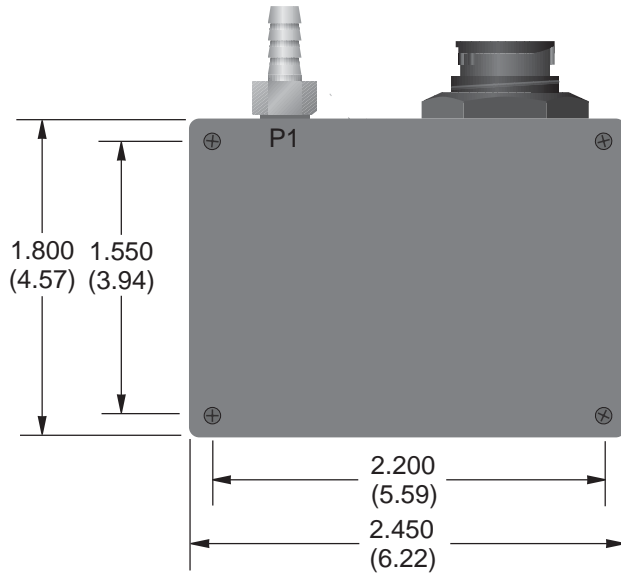
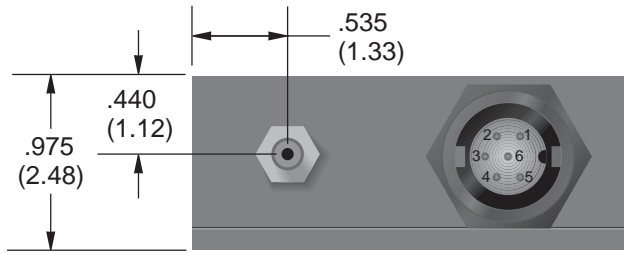

Mounting Holes: #4-40 x ∇ .500 (1/27)
4 places, back side only

Figure 9.1a—HPB Case Outline Standard

Figure 9.1b—HPB Case Outline CE Mark

HBP/A	CE	Signal name
1	A	RS-232 (TD) / RS-485 (B)
2	B	RS-232 (TD) / RS-485 (A)
3	C	Case Ground
4	D	Common Ground (GD)
5	E	DC power In
6	F	NC

Figure 9.2—Electrical Connector

DEC	HEX	ASCII	KEY	DEC	HEX	ASCII	DEC	HEX	ASCII	DEC	HEX	ASCII
0	00	NUL	ctrl @	32	20	SP	64	40	@	96	60	'
1	01	SOH	ctrl A	33	21	!	65	41	a	97	61	a
2	02	STX	ctrl B	43	22	"	66	42	B	98	62	b
3	03	ETX	ctrl C	35	23	#	67	43	C	99	63	c
4	04	EOT	ctrl D	36	24	\$	68	44	D	100	64	d
5	05	ENQ	ctrl E	37	25	%	69	45	E	101	65	e
6	06	ACK	ctrl F	38	26	&	70	46	F	102	66	f
7	07	BEL	ctrl G	39	27	'	71	47	G	103	67	g
8	08	BS	ctrl H	40	28	(`	72	48	H	104	68	h
9	09	HT	ctrl I	41	29)	73	49	I	105	69	i
10	0A	LF	ctrl J	42	2A	*	74	4A	J	106	6A	j
11	0B	VT	ctrl K	43	2B	+	75	4B	K	107	6B	k
12	0C	FF	ctrl L	44	2C	,	76	4C	L	108	6C	l
13	0D	<cr>	ctrl M	45	2D	-	77	4D	M	109	6D	m
14	0E	SO	ctrl N	46	3E	.	78	4E	N	110	6E	n
15	0F	SI	ctrl O	47	2F	/	79	4F	O	111	6F	o
16	10	DLE	ctrl P	48	30	0	80	50	P	112	70	p
17	11	DC1	ctrl Q	49	31	1	81	51	Q	113	71	q
18	12	DC2	ctrl R	50	32	2	82	52	R	114	72	r
19	13	DC3	ctrl S	51	33	3	83	53	S	115	73	s
20	14	DC4	ctrl T	52	34	4	84	54	T	116	74	t
21	15	NAK	ctrl U	53	35	5	85	55	U	117	75	u
22	16	SYN	ctrl V	54	36	6	86	56	V	118	76	v
23	17	ETB	ctrl W	55	37	7	87	57	W	119	77	w
24	18	CAN	ctrl X	56	38	8	88	58	X	120	78	x
25	19	EM	ctrl Y	57	39	9	89	59	Y	121	79	y
26	1A	SUB	ctrl Z	58	3A	:	90	5A	Z	122	7A	z
27	1B	ESC	ctrl [59	3B	;	91	5B	[123	7B	{
28	1C	FS	ctrl \	60	3C	,	92	5C	\	124	7C	
29	1D	GS	ctrl]	61	3D	=	93	5D]	125	7D	}
30	1E	RS	ctrl ^	62	3E	>	94	5E	^	126	7E	~
31	1F	US	ctrl _	63	3F	?	95	5F	_	127	7F	DEL

*ASCII - American Standard for Coded Information Interchange

Table 9.1—ASCII Conversion Table, Decimal to Hexadecimal

EIA-2323-E or RS-232	Pin # DB-25	Pin # DB-9	SIGNAL STATE	Threshold Voltages	
				Signal With Respect To SG	Signal A With Respect To Signal B
				RS-232	RS-485
Shield	1				
Transmit Data (TD)	2	3			
Receive Data (RD)	3	2	“ 0” , Asserted, ON, Space, Active	+3 to +25 VDC	+1.5 to +6 VDC (Transmitter) +0.2 to +12 VDC (Receiver)
Request to Send (RTS)	4	7			
Clear to Send (CTS)	5	8	“ 1” , Disasserted, OFF, Mark, Inactive	-3 to -25 VDC	-1.5 to -6 VDC (Transmitter) -0.2 to -7 VDC (Receiver)
DCE Ready (DSR)	6	6			
Signal Ground (SG)	7	5			
Received Line Signal Detector (DCD)	8	1			
DTE Ready (DTR)	0 2	4			
Ring Indicator	2 2	9			

Note: Some RS-485 equipment uses “+” and “-” descriptors.
The “-” corresponds to “A” and the “+” corresponds to “B”.

Table 9.3—Electrical Signal Levels

**Table 9.2—RS-232 Standard Pin
Connections**

Customer Service Representative

(800) 323-8295 fax: (763) 954-2257

E-Mail: ssec.customer.service@honeywell.com

Web Site: www.ssec.honeywell.com

No part of this manual may be reproduced or transmitted in any form or by any means, electronic or mechanical, including photocopying and recording, for any purpose, without the express written permission of Honeywell, Inc. Honeywell reserves the right to make changes to any products or technology herein to improve reliability, function or design. Honeywell does not assume any liability arising out of the application or use of any product or circuit described herein; neither does it convey any license under its patent rights nor the rights of others.

©Copyright 2001 Honeywell Inc., All rights reserved. Printed in U.S.A.

Honeywell International
Solid State Electronics Center
12001 State Highway 55
Plymouth, MN 55441
800-323-8295
FAX (763) 954-2257